

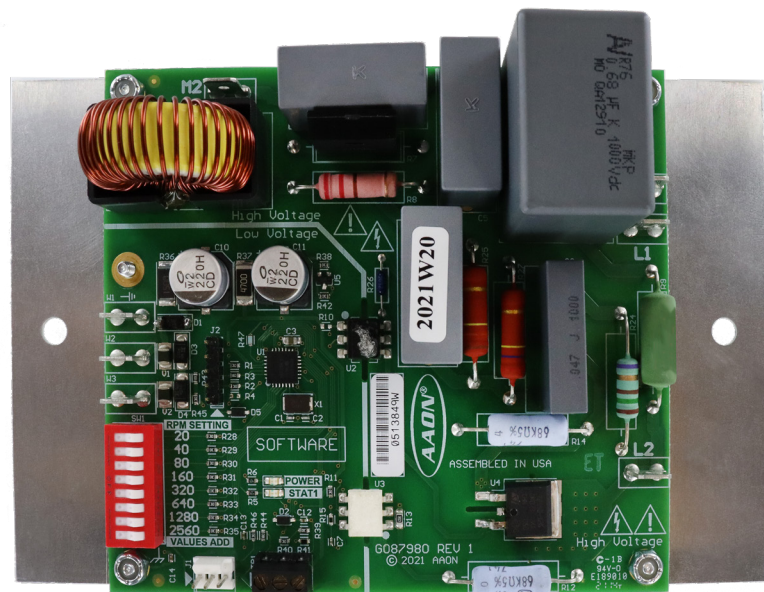

Motor Speed Controller Technical Guide

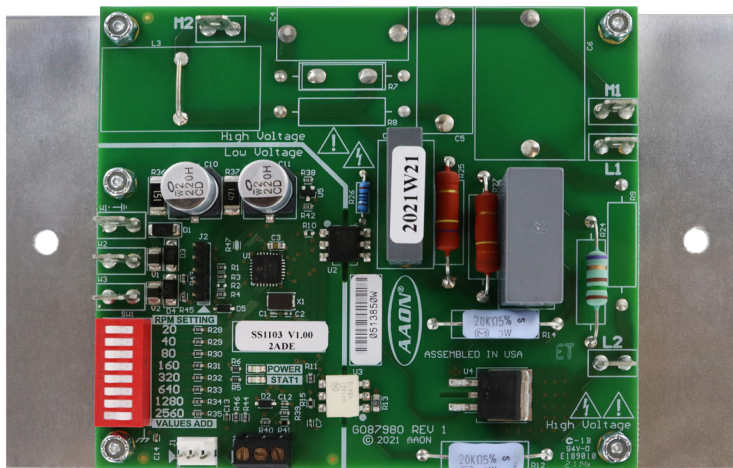

PRODUCT NAME REVISION LOG

REVISION AND DATE	CHANGE
Rev. B, October 4, 2023	Updated the logic power source in the 240V and 480V specification tables
Rev. A, September 16, 2021	Original

PRODUCT NAME PARTS REFERENCE

PART DESCRIPTION	PART NUMBER
Motor Speed Controller (240 V)	ASM02907
Motor Speed Controller (480 V)	ASM02908



www.aaon.com

**All manuals are also available for download from
www.aaon.com/controlsmanuals.**

AAON
2425 South Yukon Ave.
Tulsa, OK 74107-2728
www.aaon.com

Factory Technical Support Phone: 918-382-6450
AAON Controls Support: 866-918-1100

It is the intent of AAON to provide accurate and current product information. However, in the interest of product improvement, AAON reserves the right to change pricing, specifications, and/or design of its product without notice, obligation, or liability.

AAON P/N:G097900, Rev. B

© October 2023 AAON Inc. All rights reserved.

AAON® is a registered trademark of AAON, Inc., Tulsa, OK. AAON assumes no responsibility for errors or omissions in this document.

This document is subject to change without notice.

OVERVIEW 5
 General Information 5
 Dip Switch Settings 6
 Motor Speed Controller Dimensions 7

INSTALLATION AND WIRING 8
 Wiring 8
 Two Speed Wiring 9
 Inputs and Outputs 10

SEQUENCE OF OPERATIONS11
 Operation Modes11

FIGURES

Figure 1:	Motor Speed Controller 240 V vs. 480 V	5
Figure 2:	Motor Speed Controller Dip Switch Settings	6
Figure 3:	Motor Speed Controller Dimensions.....	7
Figure 4:	Two Speed Wiring	9

TABLES

Table 1:	Dip Switch Settings	5
Table 2:	Motor Speed Controller 240 V Specifications	8
Table 3:	Motor Speed Controller 480 V Specifications	8
Table 4:	Inputs and Outputs	10

Overview

The Motor Speed Controller is designed to control the speed of alternating current (AC) induction motors in combustion air blowers.

The Motor Speed Controller is used with blower motors with Hall effect tachometer sensors included to help facilitate blower speed control.

Features

There are two Motor Speed Controller options, the 240 V and the 480 V. Both controllers function the same, but are equipped with a different voltage power supply. See **Figure 1, this page** for details. The Motor Speed Controller controls speed based on the dip switch settings. The controller provides two speed modes, low and high speed. The two modes are controlled by 24 VAC control power inputs.

CAUTION: The controller uses a phase control method to adjust the voltage supplied to the motor. Confirm with the motor manufacturer that the motor being controlled is acceptable for this type of operation. Motor type must be permanent split capacitor (PSC) or shaded pole and be equipped with a one pulse per revolution Hall effect tachometer sensor.

Dip Switch Settings

In Two Speed applications, the low speed is set by the sum of the rpm values for all switches that are in the open/off position. See **Table 1, this page** for dip switch settings.

Dip Switch	RPM
1	20
2	40
3	80
4	160
5	320
6	640
7	1280
8	2560

Table 1: Dip Switch Settings

NOTE: If the dip switch setting is outside of the 1000-3400 rpm range, it is invalid and the fan will run at 100%.

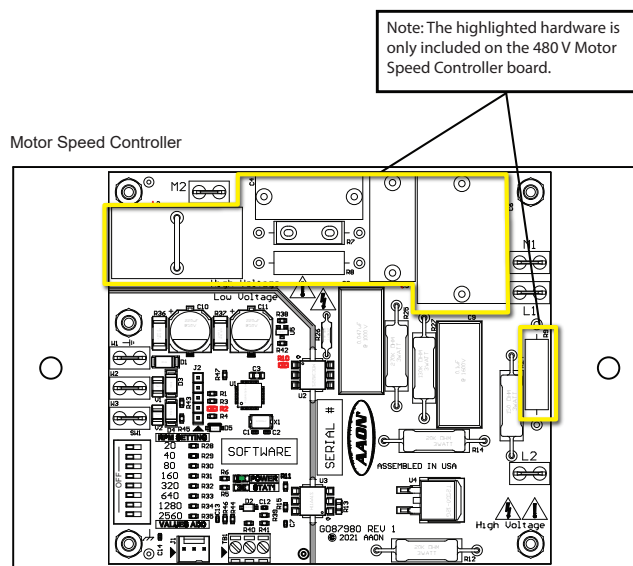

Figure 1: Motor Speed Controller 240 V vs. 480 V

OVERVIEW

Dip Switch Settings

Dip Switch Calculation

To determine the motor speed, calculate the sum of the values for all switches in the open/off position. For example, if switches 1, 3, 5, and 7 are open/off, the motor speed is 1700. See **Figure 1**, [this page](#) for details.

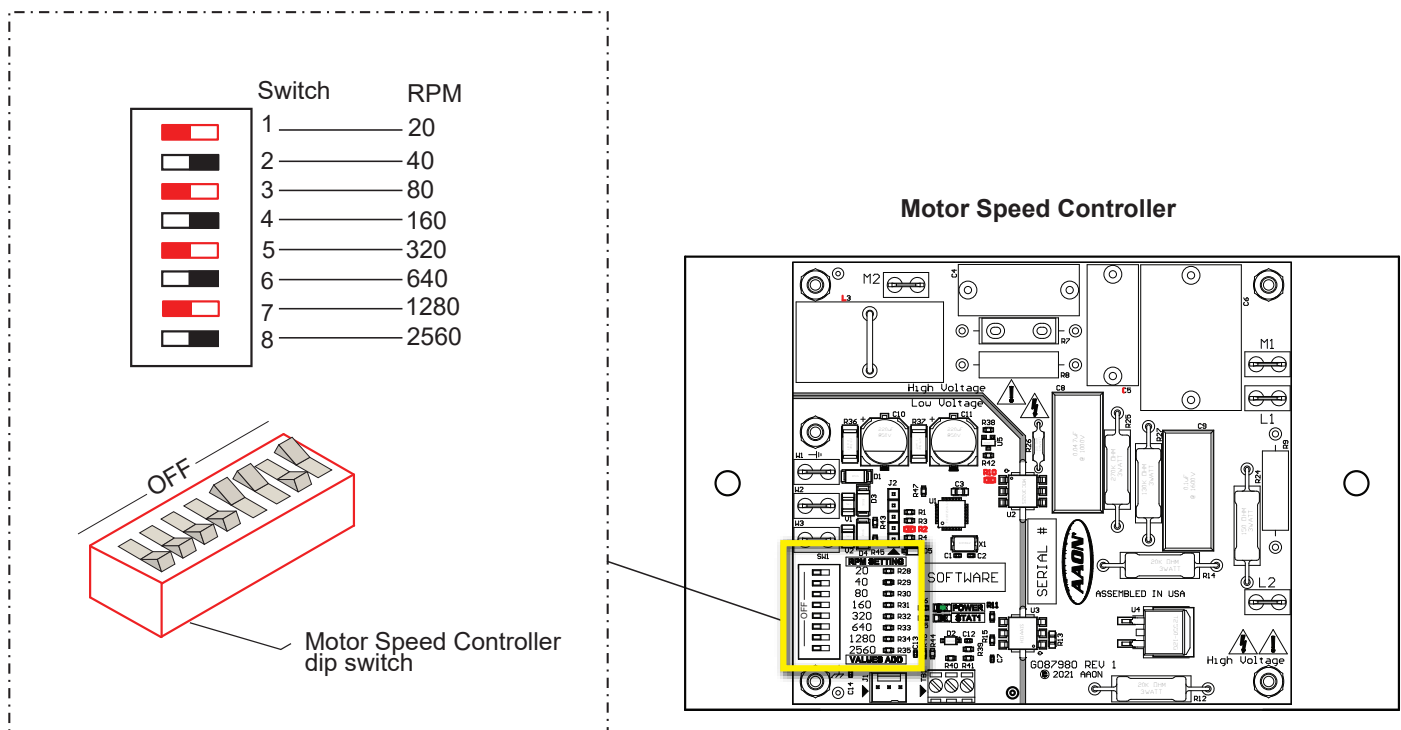
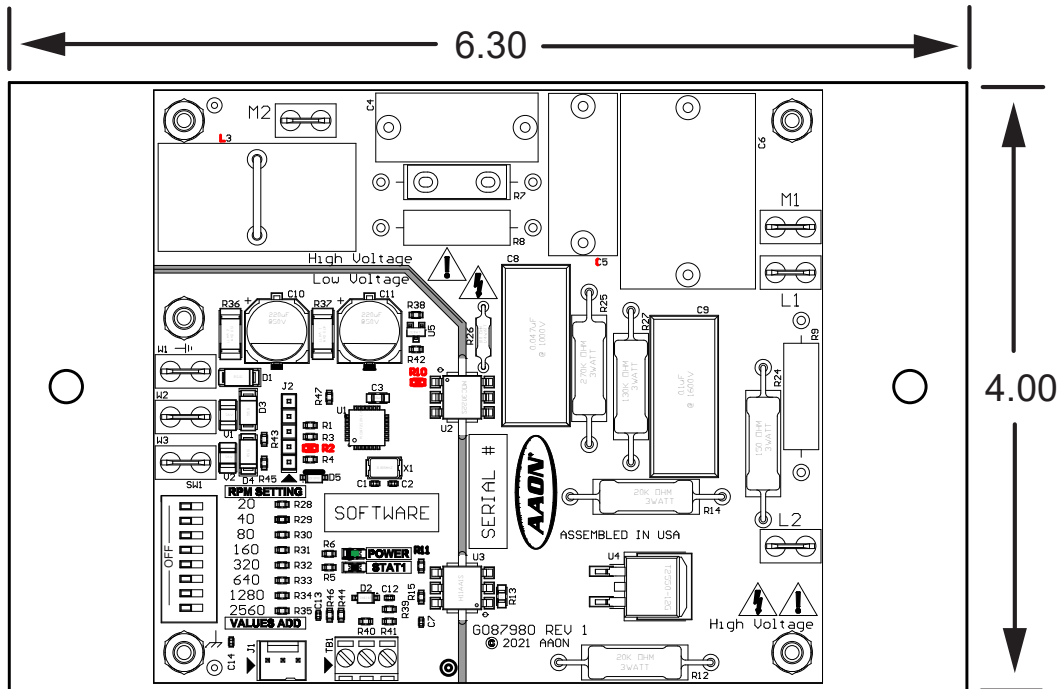

Figure 2: Motor Speed Controller Dip Switch Settings

Motor Speed Controller Dimensions



Note: All dimensions are in inches.

Figure 3: Motor Speed Controller Dimensions

INSTALLATION AND WIRING

Wiring

Wiring

See **Tables 2 and 3, this page** for the Motor Speed Controller 240 V and 480 V specifications.

Motor Speed Controller 240 V	
Specification	Value
Logic Power Source	18-30 VAC@3VA
Motor Power Source	204-254 VAC
Power AC Frequency	59-61 Hz
Motor Current Rating	4 A
Motor Compatibility	Permanent Split Capacitor or Shaded Pole
Full Speed Startup Time	15 seconds
Power Connections	1/4" quick-connect tabs
Analog Input Connections	Terminal Block, 14 GA Max
Tach Sensor Connections	3-pin 0.1" MTA Connector
Analog Control Range (2-10V)	1000-3400 RPM
Storage Temperature	-40°C to + 85 °C
Operating Temperature	-40°C to + 70 °C
UL Classification	UL 60730-1, Automatic Electrical Controls

Table 2: Motor Speed Controller 240 V Specifications

WARNING: Remove all power to the controller before making any connections or adjustments to avoid electrical shock or damage to the unit.

Motor Speed Controller 480 V	
Specification	Value
Logic Power Source	18-30 VAC@3VA
Motor Power Source	408-528 VAC
Power AC Frequency	59-61 Hz
Motor Current Rating	4 A
Motor Compatibility	Permanent Split Capacitor or Shaded Pole
Full Speed Startup Time	15 seconds
Power Connections	1/4" quick-connect tabs
Analog Input Connections	Terminal Block, 14 GA Max
Tach Sensor Connections	3-pin 0.1" MTA Connector
Analog Control Range (2-10V)	1000-3400 RPM
Storage Temperature	-40°C to + 85 °C
Operating Temperature	-40°C to + 70 °C
UL Classification	UL 60730-1, Automatic Electrical Controls

Table 3: Motor Speed Controller 480 V Specifications

Control Power

There are three 1/4 inch quick-connect tabs for 24 VAC control power signal connections. The W1 terminal is 24 VAC common and ground. The W2 terminal is the high speed input, and terminal W3 is the low speed input. If W2 is supplied with 24 VAC power and W3 is unpowered, the motor will run at full speed. If W2 and W3 receive power, or if W3 receives power while W2 is unpowered, the motor speed will be controlled to the analog input voltage or the dip switch setting.

Line and Motor Connections

The L1 and L2 quick-connect terminals should be connected to a 240 V or 480 V power supply. The M1 and M2 terminals should be connected to the motor.

Mounting

The Motor Speed Controller has a factory mounted aluminum base plate. The metal base plate helps the controller regulate temperature and facilitate proper heat dissipation.

Two Speed Wiring

In Two Speed Mode, when 24 VAC power is applied only to terminal W2, the motor will operate at high speed. If 24 VAC power is applied to terminal W3 (instead of, or in addition to, terminal W2), the motor will operate at a speed determined by the dip switch setting. See **Figure 4, this page** for wiring details.

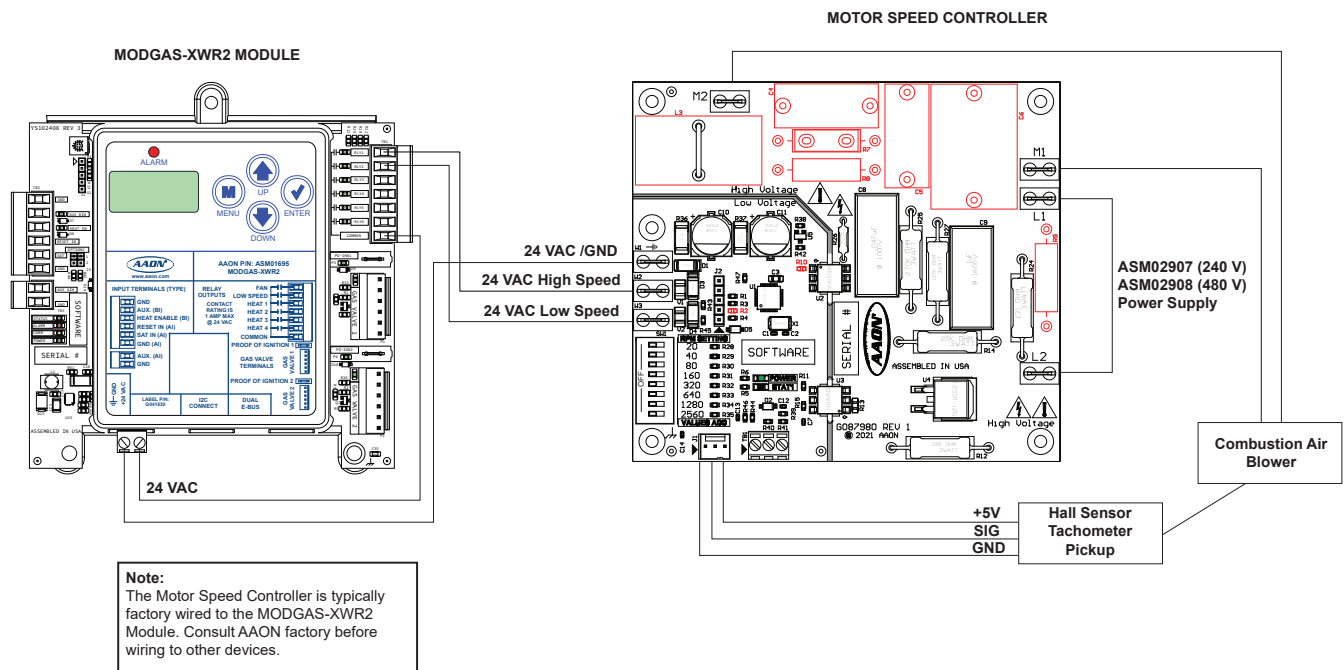

Figure 4: Two Speed Wiring

Inputs and Outputs

I/O Map

See Table 4, this page for Motor Speed Controller inputs and outputs.

Motor Speed Controller	
Inputs	
W1	Ground (for 24 VAC control voltage)
J1	Fan tachometer feedback
L1	Line voltage (240 VAC or 480 VAC)
L2	Line voltage (240 VAC or 480 VAC)
Binary Inputs	
W2	Fan high speed (24 VAC)
W3	Fan low speed (24 VAC)
Analog Inputs	
TB1	2-10 VDC variable fan speed input
Outputs	
M1	Fan motor
M2	Fan motor

Table 4: Inputs and Outputs

Operation

The Motor Speed Controller is used to control the speed of PSC or shaded-pole fan motors. The binary inputs are used to switch between High and Low Speed Modes. In High Speed Mode, the fan operates at 100%. In Low Speed Mode, the fan is controlled by the rpm setpoint determined by the dip switch setting. Fan speed is provided to the controller by a Hall effect tachometer in the motor. If the fan speed is above or below setpoint, the voltage supplied to the fan will be decreased or increased to maintain the fan speed setpoint.

Off Mode

In Off Mode, there is no W2 or W3 input and the fan output is de-energized.

High Speed Mode

In High Speed Mode, the W2 input is energized with 24 VAC power and the W3 input is de-energized. The fan runs at full speed. If the W2 and W3 inputs are both de-energized, the fan output will de-energize. If the W3 input is energized with 24 VAC power, the fan will switch to low speed.

Low Speed Mode

In Low Speed Mode, the fan will operate when the W3 input is energized or when the W2 and W3 inputs are energized with 24 VAC power.

When the fan is powered on, it will run at high speed for 15 seconds before switching to low speed.

The fan speed will be maintained at a speed determined by the dip switch settings.

In Two Speed Mode, the fan rpms are labeled on the circuit board. The switch position should be set to OFF to add that position's rpm value. For example, for 2560 rpm, positions 1-7 should be set to ON and position 8 should be set to OFF.

If the W3 input is de-energized, the fan will switch to high speed operation.

The fan output will de-energize if both W2 and W3 inputs are de-energized.

Motor Speed Controller Technical Guide

G097900 · Rev. B · 231004

AAON Controls Support: 866-918-1100
Monday through Friday, 7:00 AM to 5:00 PM
Central Standard Time

Controls Support website:
www.aaon.com/controlstechsupport

AAON Factory Technical Support: 918-382-6450
techsupport@aaon.com

NOTE: Before calling Technical Support, please have the model and serial number of the unit available.

PARTS: For replacement parts, please contact your local AAON Representative.



2425 South Yukon Ave • Tulsa, OK • 74107-2728
Ph: (918) 583-2266 • Fax: (918) 583-6094
AAON P/N: G097900, Rev. B

Printed in the USA • Copyright October 2023 • All Rights Reserved