

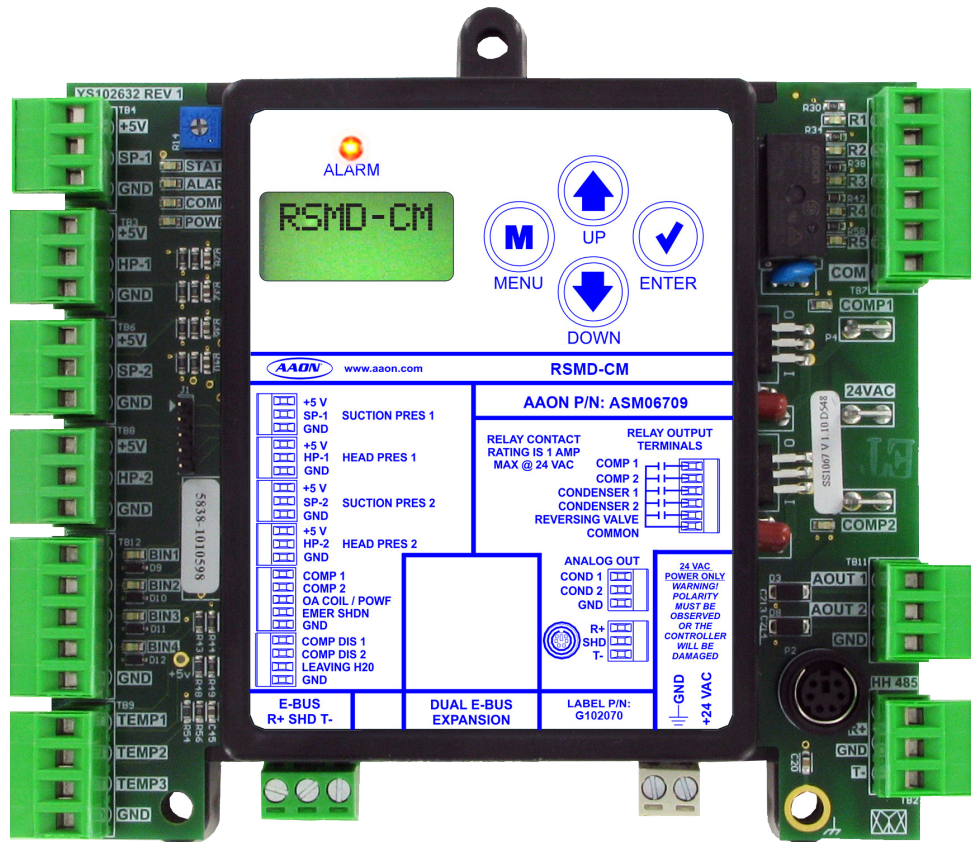

RSMD-CM Technical Guide



RSMD-CM REVISION LOG

REVISION AND DATE	CHANGE
Rev. A, December 22, 2021	First edition

RSMD-CM PARTS REFERENCE

PART DESCRIPTION	PART NUMBER
Refrigerant System Module for Digital Compressors with Condenser Fans with Microchannel Coils (RSMD-CM)	ASM06709
VCCX2 Controller	ASM01698
Prism 2	ASM02533
IP Module Kit	ASM01902
CommLink 5	ASM01874
E-BUS Cable Assembly E-BUS Power and Comm 1.5 ft., 3 ft., 10 ft., 25 ft., 50 ft., 75 ft., 100 ft., 150 ft., 250 ft., and 1000 ft. spool	G029440 (1.5 ft.), G012870 (3 ft.), G029460 (10 ft.), G045270 (25 ft.), G029510 (50 ft.), G029530 (75 ft.), G029450 (100 ft.), G029470 (150 ft.), V36590 (250 ft.), G018870 (SPOOL)
Modular Service Tool SD - Operator Interface	ASM01895



www.aon.com

**All manuals are also available for download from
www.aon.com/controlsmanuals.**

AAON
2425 South Yukon Ave.
Tulsa, OK 74107-2728
www.aon.com
Factory Technical Support Phone: 918-382-6450

AAON® Controls Support: 866-918-1100
It is the intent of AAON® to provide accurate and current product information. However, in the interest of product improvement, AAON® reserves the right to change pricing, specifications, and/or design of its product without notice, obligation, or liability.

AAON Part Number: G102430, Rev. A
Copyright December 2021 AAON, Inc.
AAON® is a registered trademark of AAON, Inc., Tulsa, OK.
Copeland Scroll™ is a registered trademark of Emerson Electric Co., Sidney, OH

AAON® assumes no responsibility for errors or omissions in this document. This document is subject to change without notice.

OVERVIEW 5
 Features and Applications..... 5
 Dimensions 6

INSTALLATION AND WIRING 7
 Electrical and Environmental Requirements 7

WIRING 8
 Inputs Wiring 8
 Outputs Wiring 9

INPUTS AND OUTPUTS 10
 Inputs/Outputs Map..... 10
 Inputs and Outputs.....11

SEQUENCE OF OPERATIONS 12
 Cooling Mode, Dehumidification, and Head Pressure Control..... 12

LCD SCREENS 13
 LCD Display Screen and Navigation Keys..... 13
 Main Screens Map 14
 Module Screens 15
 System Status Screens..... 16
 Sensor Status Screens 17
 Setpoint Status Screens 18
 Alarms Screens..... 19
 Alarms History Screens and Protected Screens Map..... 21
 Configuration Screens 22
 Diagnostic Screens 23
 Alarm Counts and Address Screens 25

TROUBLESHOOTING 26
 LED Diagnostics 26
 Suction Pressure Transducer Testing 27
 Copeland™ Discharge Thermistor Temperature Sensor Testing 28
 Temperature Sensor Testing 29
 Head Pressure Transducer 30

APPENDIX A: CONDENSER OPTIONS 31
 Two Condensers Per Module (Default)..... 31
 Single Condenser Per Module 33
 Single Condenser Per Two Modules..... 35
 Single Condenser for Three Modules 37
 A1/B1 and A2/B2 Condenser Configuration..... 39
 ON/OFF Condenser Options 42

FIGURES

Figure 1:	RSMD-CM Dimensions	6
Figure 2:	RSMD-CM Inputs Wiring	8
Figure 3:	RSMD-CM Outputs Wiring	9
Figure 4:	LCD Display and Navigation Keys	13
Figure 5:	RSMD-CM LED Locations	26
Figure 6:	Two Condenser Operation (Default).....	31
Figure 7:	Prism 2 Condenser Configuration - Two Condenser Operations (Default)	32
Figure 8:	Single Condenser Per Module.....	33
Figure 9:	Prism 2 Condenser Configuration - Single Condenser Per Module	34
Figure 10:	Single Condenser Per Two Modules	35
Figure 11:	Prism 2 Condenser Configuration - Single Condenser Per Two Modules.....	36
Figure 12:	Single Condenser for Three Modules.....	37
Figure 13:	Prism 2 Condenser Configuration - Single Condenser for Three Modules	38
Figure 14:	A1/B1 Wiring.....	39
Figure 15:	A2/B2 Wiring.....	40
Figure 16:	Prism 2 Condenser Configuration - A1/B1 and A2/B2 Condenser Configuration	41
Figure 17:	Prism 2 Condenser Configuration - ON/OFF Condenser Options.....	42

TABLES

Table 1:	RSMD-CM Module Electrical and Environmental Requirements.....	7
Table 2:	RSMD-CM Inputs and Outputs	10
Table 3:	Navigation Key Functions.....	13
Table 4:	Suction Pressure Transducers Coil Pressure/Temperature/Voltage Chart for R410-A Refrigerant	27
Table 5:	Discharge Thermistor Temperature/Resistance	28
Table 6:	0-5V Temperature Sensor - Voltage and Resistance for Type III Sensors.....	29
Table 7:	Head Pressure Transducer Chart	30

Features and Applications

The Refrigerant System Module for Digital Compressors with Condenser Fans with Microchannel Coils (RSMD-CM) can monitor and control up to two compressors and condensers. The compressors can be in either a tandem or non-tandem configuration. The module is designed for R410-A refrigerant.

The RSMD-CM is for units that match all of the following criteria:

1. One or two circuits.
2. Compressors may be any mix of fixed, two-step, and digital.
3. Reheat is present on the first circuit.

The RSMD-CM must be connected to a VCCX2 Controller. Up to four RSMD-CM Modules can be connected, depending on the size of the system. There are two E-BUS expansion ports which allow the use of communicating sensors and E-BUS modules.

The RSMD-CM Module provides the following:

- Modulates the compressors to satisfy the Suction Coil (Saturation) Temperature. The Suction Coil (Saturation) Temperature Setpoint is reset by the VCCX2 Controller to maintain the Supply Air Temperature during Cooling Mode. During Dehumidification Mode, it controls the compressors to directly maintain the Suction (Saturation) Temperature Setpoint.
- When the Heat Pump is in Heating Mode, the RSMD-CM modulates and stages the compressors to maintain a given Supply Air Temperature Setpoint.
- Modulates the condenser to maintain the Head Pressure Setpoint.
- Provides alarms and safeties for the compressor and condenser operation.
- For convenience on split systems, with the proper communication cable installed, the RSMD-CM provides a port for connecting the Modular Service Tool SD to the VCCX2.
- Provides a 2 x 8 LCD character display and four buttons that allow access to system status, setpoints, alarms and some configuration settings.

OVERVIEW

Dimensions

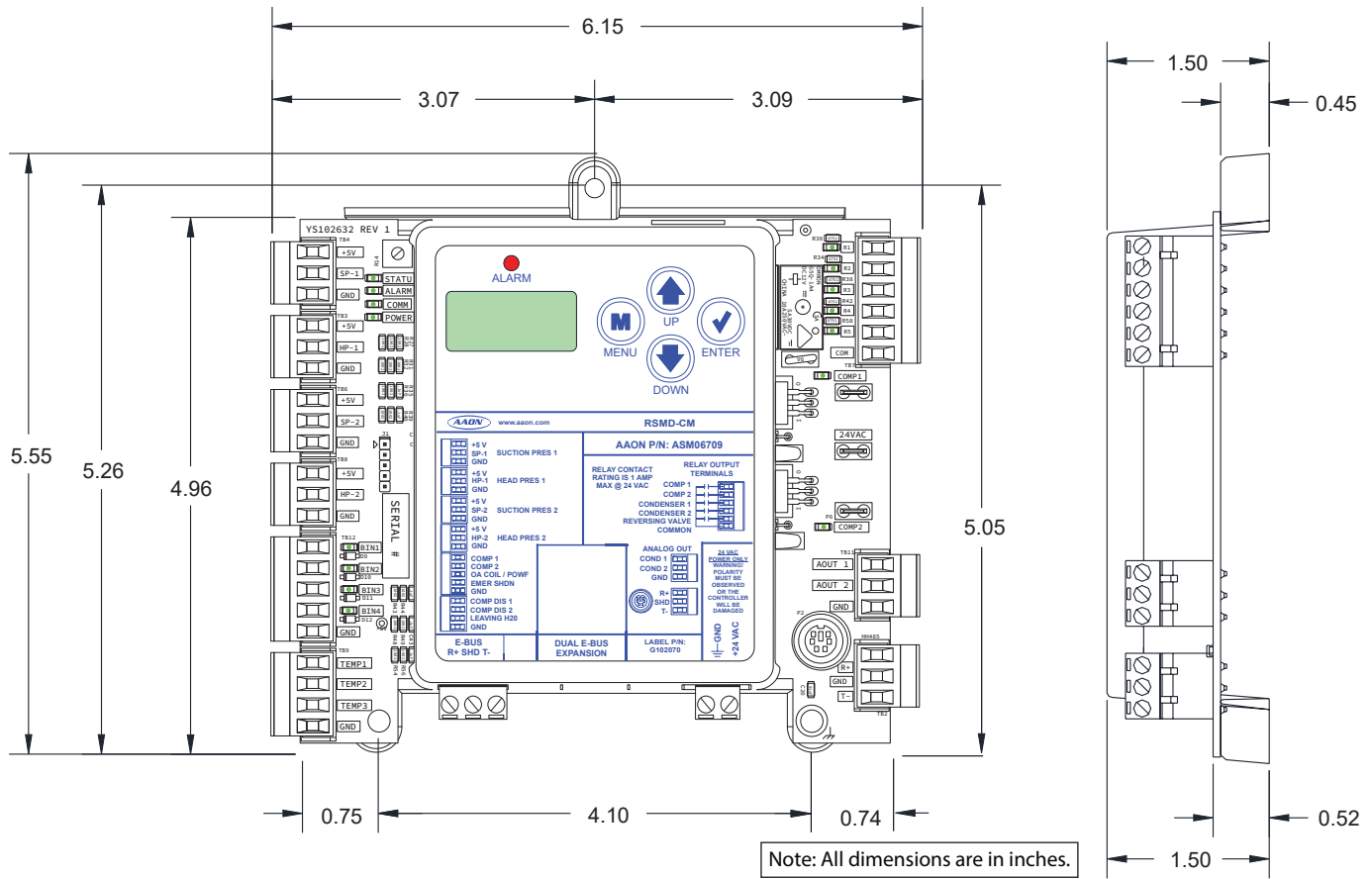

Figure 1: RSMD-CM Dimensions

General

Correct wiring of the AAON controller and its modules is the most important factor in the overall success of the installation process. The AAON controller and modules are factory installed and wired at the AAON factory. Some of the following information may not apply to your installation if it was pre-wired at the factory. However, if troubleshooting of the controller or modules is required, it is a good idea to be familiar with the system wiring.

Wiring

The modules must be connected to an 18-30 VAC power source of the proper size for the calculated VA load requirements. All transformer sizing should be based on the VA ratings listed in **Table 1, this page.**

Control Device	Voltage	VA Load	Operating Temperature	Humidity (Non-Condensing)
RSMD-CM Module	18-30VAC	18	-22°F to 158°F -30°C to 70°C	0-95% RH
	Inputs		Resistive Inputs require 10KΩ Type 3 Thermistor	
	Outputs		Relay Outputs: 1 amp maximum per output.	
		24VAC Inputs provide 4.7kΩ Load		

Table 1: RSMD-CM Module Electrical and Environmental Requirements

NOTE: If the temperature at the controller is below -4°F (-20°C), the display refresh rate could be less responsive.

WARNING: When using a single transformer to power more than one controller or expansion module, the correct polarity must always be maintained between the boards. Failure to observe correct polarity will result in damage to the unit controller, RSMD-CM, and any associated module.

Please carefully read and apply the following information when wiring the unit controller, RSMD-CM, and any associated module.

1. All wiring is to be in accordance with local and national electrical codes and specifications.
2. All 24 VAC wiring must be connected so that all ground wires remain common. Failure to follow this procedure can result in damage to the controller and connected devices.
3. Minimum wire size for 24 VAC wiring should be 18-gauge.
4. Minimum wire size for all sensors should be 24-gauge. Some sensors require two-conductor wire and some require three-or four-conductor wire.
5. Minimum wire size for 24 VAC thermostat wiring should be 22-gauge.
6. Be sure that all wiring connections are properly inserted and tightened into the terminal blocks. Do not allow wire strands to stick out and touch adjoining terminals which could potentially cause a short circuit.
7. When communication wiring is used to interconnect HVAC unit controllers together or to connect to other communication devices, all wiring must be plenum-rated, minimum 18-gauge, two-conductor, twisted pair with shield. AAON can supply communication wire that meets this specification and is color coded for the network or local loop. Please consult your AAON distributor for information. If desired, Belden #82760 or equivalent wire may also be used.
8. Before applying power to the HVAC unit controller, RSMD-CM Modules, and any associated modules, be sure to recheck all wiring connections and terminations thoroughly.

Powering Up

When the controller and modules are first powered up, the POWER LED should light up and stay on continuously. If it does not light up, check to be sure that you have 24 VAC connected to the controller, that the wiring connections are tight, and that they are wired for the correct polarity. The 24 VAC power must be connected so that all ground wires remain common. If after making all these checks, the POWER LED does not light up, please contact AAON Controls Support for assistance.

WIRING

Inputs Wiring

RSMD-CM Wiring

The RSMD-CM provides three analog inputs, four binary inputs, five relays, and two analog outputs. See **Figure 2, this page**, for inputs wiring and **Figure 3, page 9**, for outputs wiring.

WARNING: Observe polarity! All boards must be wired with GND-to-GND and 24-VAC-to-24 VAC. Failure to observe polarity will result in damage to one or more of the boards. Expansion modules must be wired in such a way that the expansion modules and the controller are always powered together. Loss of power to the expansion module will cause the controller to become inoperative until power is restored to the expansion module.

Suction Pressure Transducer Wiring

The Suction Pressure Transducers must be wired as shown in **Figure 2, this page**. It is typically required for all VCCX2 applications.

The Suction Pressure Transducers are used to measure suction pressure at the HVAC unit's DX evaporator coil suction line. This suction line pressure is converted to saturated refrigerant temperature. The saturated refrigerant temperature is used to properly control the compressors to maintain a given Suction Coil (Saturated) Temperature Setpoint. In Cooling Mode, the VCCX2 resets the Suction Coil (Saturated) Temperature Setpoint to maintain a given Supply Air Temperature Setpoint. In Dehumidification Mode, the Suction Coil (Saturated) Temperature Setpoint is a user configurable setpoint that can be reset based on indoor humidity levels.

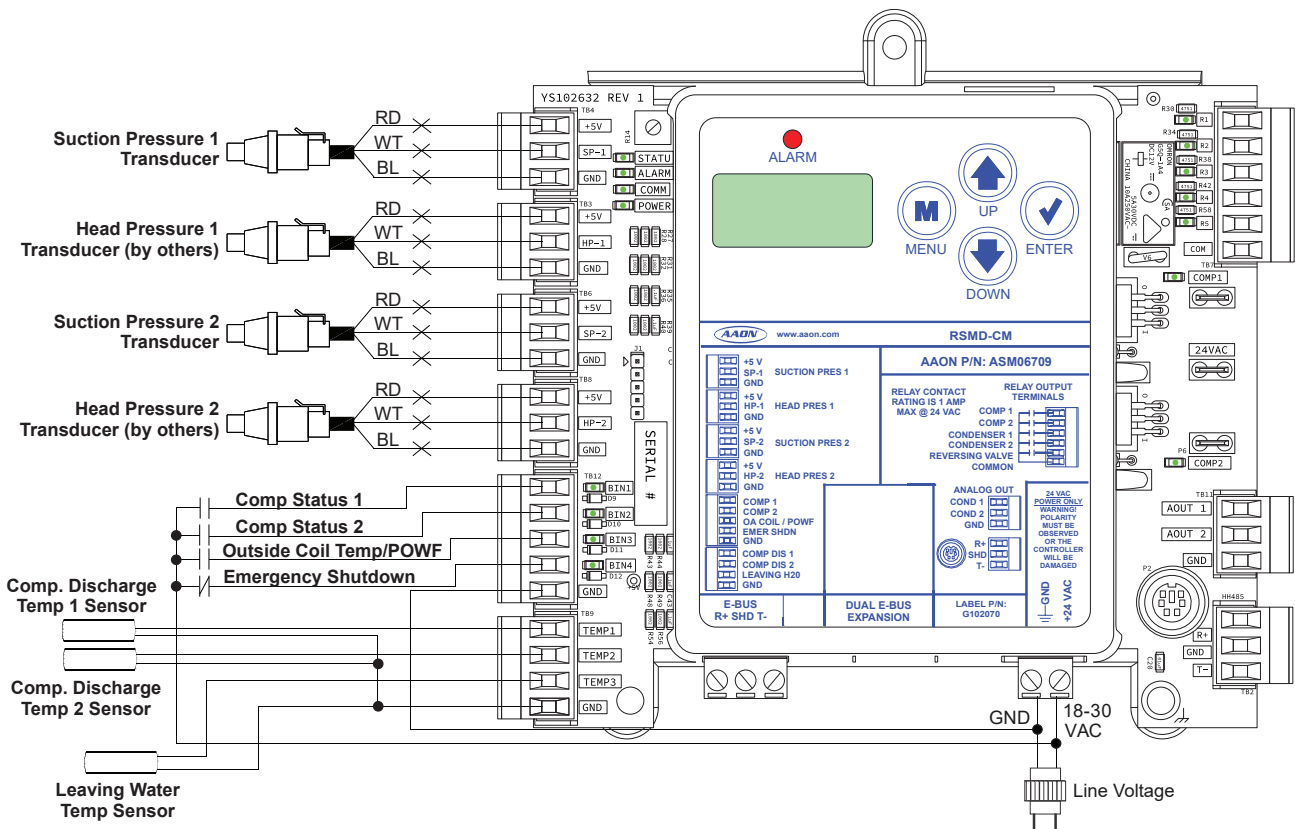

Figure 2: RSMD-CM Inputs Wiring

CAUTION: Suction pressure transducers should be installed in a vertical portion of the suction line to prevent refrigerant oil from accumulating in the sensor.

NOTE: If there are two compressors on a single circuit (a tandem circuit), Suction Pressure 2, Head Pressure 2, and Condenser Signal 2 would not be used.

Head Pressure Control

The Head Pressure Transducers are used to measure Head Pressure at the discharge line. This Head Pressure is used to drive the condenser fans with a 0-10 VDC output signal or valve with a 2-10 VDC output signal to maintain a given Head Pressure Setpoint.

Compressor Discharge Sensors

The Digital Compressor Discharge Temperature Sensor monitors the discharge temperature from the digital compressor to protect against overheating.

Leaving Water Temperature Sensor

The Leaving Water Temperature Sensor is used to measure the Leaving Water Temperature when used on a water source heat pump unit.

NOTE:
All relay outputs are normally open and rated for 24 VAC power only.
1 Amp maximum load.

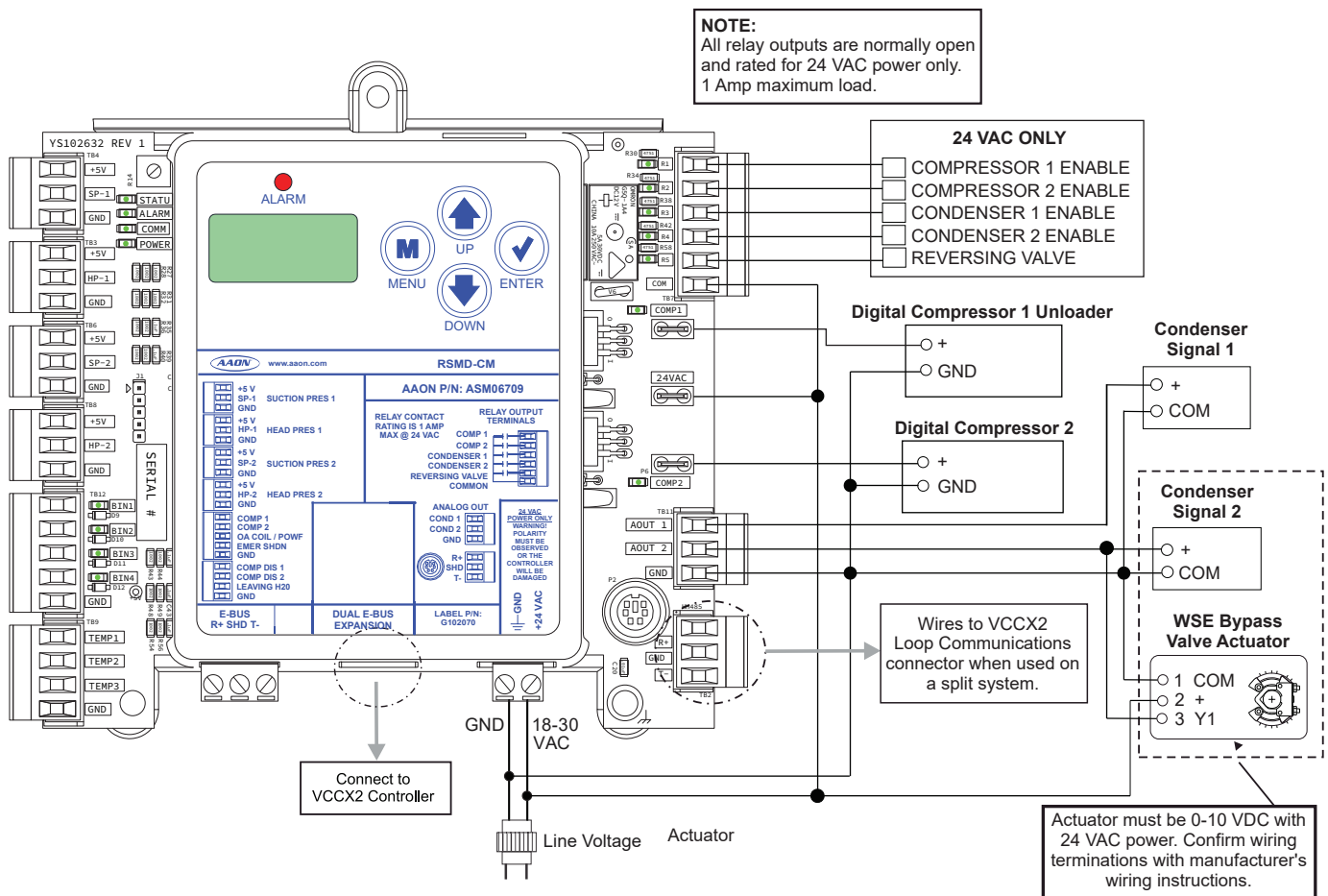

Figure 3: RSMD-CM Outputs Wiring

INPUTS AND OUTPUTS

Inputs/Outputs Map

Inputs/Outputs Map

See Table 2, this page, for the RSMD-CM inputs and outputs.

REFRIGERATION SYSTEM MODULE FOR DIGITAL COMPRESSORS	
Analog Inputs	
1	Suction Pressure 1 (SP-1)
2	Head Pressure 1 (HP-1)
3	Suction Pressure 2 (SP-2)
4	Head Pressure 2 (HP-2)
5	Compressor Discharge Temperature 1 Sensor (TEMP1)
6	Compressor Discharge Temperature 2 Sensor (TEMP2)
7	Leaving Water Temperature Sensor (TEMP3)
Binary Inputs	
1	Compressor Status 1 (BI1)
2	Compressor Status 2 (BI2)
3	Outdoor Coil Temperature / Proof of Water Flow (BI3)
4	Emergency Shutdown (BI4)
Analog Outputs	
1	Condenser 1 Signal (AO1)
2	Condenser 2 Fan Signal (0-10 VDC) or WSE Bypass Actuator (2-10 VDC) (AO2)
Relay Outputs (24 VAC)	
1	Compressor 1 Enable Relay (RLY1)
2	Compressor 2 Enable Relay (RLY2)
3	Condenser 1 Enable Relay (RLY3)
4	Condenser 2 Enable Relay (RLY4)
5	Reversing Valve Relay (RLY5)

NOTE: AO1 Fan is 0-10 VDC and water valve is 2-10 VDC.

Table 2: RSMD-CM Inputs and Outputs

Inputs and Outputs

+5V - VDC Power

This output is a 5 VDC output that supplies power to the Suction Pressure Transducers.

SP-1 and SP-2 - Suction Pressure Transducers

The Suction Pressure Transducers are used to measure suction pressure at the HVAC unit's DX evaporator coil suction line. This suction line pressure is converted to saturated refrigerant temperature. The saturated refrigerant temperature is used to properly control the compressors to maintain a given Suction Coil (Saturated) Temperature Setpoint. In Cooling Mode, the VCCX2 resets the Suction Coil (Saturated) Temperature Setpoint to maintain a given Supply Air Temperature Setpoint. In Dehumidification Mode, the Suction Coil (Saturated) Temperature Setpoint is a user configurable setpoint that can be reset based on indoor humidity levels.

+5V - VDC Power

This output is a 5 VDC output that supplies power to the Head Pressure Transducers.

HP-1 and HP-2 - Head Pressure Transducers

The Head Pressure Transducers are used to measure Head Pressure at the discharge line. This Head Pressure is used to drive the condenser fans to maintain a given Head Pressure Setpoint.

TEMP1 and TEMP2 - Compressor Discharge Temperature Sensor 1 and Sensor 2 Input

The Digital Compressor Discharge Temperature Sensors monitor the discharge temperature from the digital compressor to protect against overheating.

TEMP3 - Leaving Water Temperature Sensor Input

This input monitors the condenser leaving water temperature and determines if the water source condenser is operating in a safe water temperature range.

BI1 - Compressor Status 1

When this wet contact input closes, a 24 volt signal to BI1 indicates Compressor 1 is running. If BI1 (Compressor Status Input) becomes de-energized while the compressor is running, a high pressure alarm is triggered. The high pressure switch and low pressure switch are in series. Check both switches if an alarm occurs. The alarm will de-energize the compressor output for two minutes and then re-energize the output.

BI2 - Compressor Status 2

If wired non-tandem: When this wet contact input closes, a 24 volt signal to BI2 indicates Compressor 2 is running. If BI2 (Compressor Status Input) becomes de-energized while the compressor is running, a high pressure alarm will be triggered. The high pressure switch and low pressure switch are in series. Check both switches if an alarm occurs. The alarm will de-energize the compressor output for two minutes and then re-energize the output.

If wired in tandem: When this wet contact input closes, a 24 volt signal to BI2 indicates that Compressor 2 is running. If BI2 (Compressor Status Input) becomes de-energized while the compressor is running, a compressor alarm will be triggered and the compressor will de-energize RLY2, shutting down the compressor, and lock it out.

BI3 - Outdoor Coil Temperature/Proof of Water Flow Status

This input can be used for the following two options:

- **Air to Air Heat Pump:** This wet contact input monitors a Defrost Coil Temperature Switch on air to air heat pump units. If the compressors are operating in the Heating Mode and this switch closes, it will initiate a Defrost Mode.
- **Water Source Heat Pump:** This wet contact input is for the Water Proof of Flow Switch. If the Water Proof of Flow Switch contact opens while the condenser valve is operating, the controller will react to protect the system depending on the current mode of operation.

BI4 - Emergency Shutdown

This wet contact input is used to initiate shutdown of the HVAC unit when a normally closed Smoke Detector (by others), Firestat (by others), or other shutdown condition (by others) contact is opened. The controller remains active and can initiate alarm relays.

NOTE: The binary inputs require wet contacts (24 VAC only) to recognize an active input. If you provide dry contacts, the contact closure will not be recognized.

AO1 - Condenser 1 Fan Signal

This 0-10 VDC output is used to control/modulate the Condenser 1 Fan /Valve to maintain the Head Pressure Setpoint.

AO2 - Condenser 2 Fan Signal or Waterside Economizer Bypass Actuator Valve

This 0-10 VDC output is used to control/modulate the Condenser 2 Fan /Valve to maintain the Head Pressure Setpoint or this output signal is a Direct Acting 2-10 VDC output signal that is used to modulate the waterside Economizer Bypass Actuator.

RLY1 - Compressor 1 Enable

This relay enables Compressor 1.

RLY2 - Compressor 2 Enable

This relay enables Compressor 2.

RLY3 - Condenser 1 Enable

This relay enables the Condenser 1 Fan/Water Valve.

RLY4 - Condenser 2 Enable

This relay enables the Condenser 2 Fan/Water Valve.

RLY5 - Reversing Valve Enable

This relay enables the Reversing Valve.

SEQUENCE OF OPERATIONS

Cooling Mode, Dehumidification, and Head Pressure Control

Cooling Mode Operation

In the Cooling Mode, as Supply Air Temperature (SAT) rises above the Active SAT Cooling Setpoint, the compressors will stage on and modulate to maintain the Active Evaporator Coil Suction (Saturation) Temperature Setpoint. Two compressors are controlled per RSMD-CM. Multiple RSMD-CM Modules are needed when there are more than two compressors.

Modules with One Digital and One Fixed Compressor

If the digital compressor modulates to 100% and the SAT is still above the SAT Cooling Setpoint for the Cooling Stage Up Delay, then the fixed compressor will stage on. The digital compressor will then be allowed to modulate as necessary to maintain the Active Evaporator Coil Suction (Saturation) Temperature Setpoint. Minimum off times must also be met before compressors can stage on.

Modules with Multiple Digital Compressors

If the first digital compressor modulates to 100% and the SAT is still above the SAT Cooling Setpoint for the Cooling Stage Up Delay, then the second digital compressors will enable and the two digital Compressors will then modulate together to maintain the Active Evaporator Coil Suction (Saturation) Temperature Setpoint.

Staging Down Compressors

If the digital compressor(s) have modulated down to 30% for the Stage Down Delay period and the SAT has fallen below the SAT Cooling Setpoint minus the Stage Control Window, then the last compressor to have staged on (digital or fixed) will stage off assuming its Minimum Run Time has been met. Any remaining digital compressors are then allowed to modulate as needed. If the last remaining digital compressor reaches 0% for the Stage Down Delay, it will stage off.

Dehumidification Operation

The RSMD-CM activates the Cooling Stages based on the Evaporator Coil Temperature compared to the Evaporator Coil Suction (Saturation) Temperature Setpoint. The Evaporator Coil Suction (Saturation) Temperature is calculated by using the Suction Pressure Transducer and converting the pressure to temperature.

For Copeland™ Digital Scroll Compressor units, the RSMD-CM will modulate the Copeland Digital Scroll™ Compressor to maintain the Evaporator Coil Suction (Saturation) Temperature Setpoint and activate the compressors as necessary.

On units that have one digital and one fixed capacity compressor, if the fixed capacity compressor is activated, the Copeland™ Digital Scroll Compressor will only be allowed to modulate within the range of 70-100% in order to prevent the loss of reheat capacity during low load conditions. If, with both compressors on, the first digital compressor has modulated down to its 70% minimum and the Coil Suction Temperature falls below the Coil Temperature Setpoint minus the Cooling Stage Control Window, then the second compressor will stage off once its Compressor Minimum Run Time and the Stage Down Delay Times have been met. At that point, the Copeland™ Digital Scroll Compressor can modulate down as needed to maintain the Coil Temperature Setpoint.

If the RSMD-CM has two digital compressors, the first compressor will be locked at 100% and the second compressor will modulate.

Head Pressure Control

The RSMD-CM can monitor a Head Pressure Transducer and control a condenser fan or water valve to maintain a Head Pressure Setpoint.

A condenser relay is commanded on when the first compressor is enabled (except if the unit Heat Pump is in Defrost Mode). On an air cooled unit, the condenser fan will be controlled with 0-10 VDC output signal. On a water cooled unit, the water valve will be controlled with a 2-10 VDC signal.

When the Condenser Signal first activates, it maintains at 100% for 10 seconds.

In the Cooling Mode, the Condenser Signal will modulate to maintain the Cooling Head Pressure Setpoint. On units with a condenser fan, the signal can modulate between 15% and 100%. On a unit with a condenser water valve, the signal can modulate between 25% and 100%. If the Head Pressure exceeds 550 psig, the Condenser Control Signal will immediately go to 100% and a High Head Pressure Alarm will be generated. The alarm will be deactivated when the Head Pressure drops below 540 psig.

In the Dehumidification Mode, the Condenser Output Signal controls to the Reheat Head Pressure Setpoint. High Head Pressure conditions produce the same effects as in the Cooling Mode.

If no Head Pressure Transducer is detected, the Condenser Output Signal will be maintained at 100%.

LCD Display Screen and Navigation Keys

The LCD display screens and buttons allow you to view status and alarms, and enable force modes. See **Figure 4, this page**, and refer to **Table 3, this page**, for descriptions.

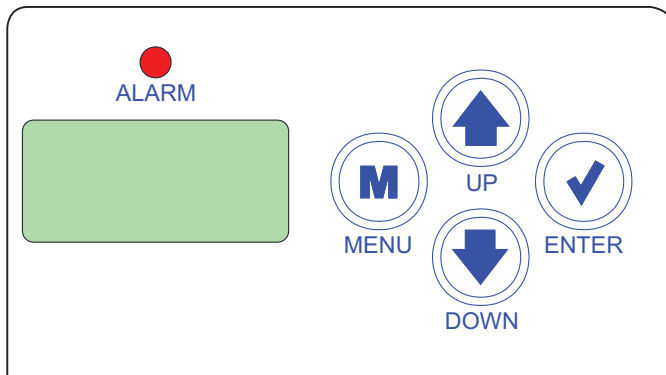

Figure 4: LCD Display and Navigation Keys

Navigation Key	Key Function
MENU 	Use the MENU key to move through screens within Main Menu categories and return to the Main Menu while at other screens.
UP 	Use this key to adjust setpoints and change configurations.
DOWN 	Use this key to adjust setpoints and change configurations.
ENTER 	Use the ENTER key to navigate through the Main Menu Screen categories.

Table 3: Navigation Key Functions

Main Screens Map

Main Screens Map

Refer to the following map when navigating through the LCD Main Screens. To scroll through the screens, press the **<MENU>** button.

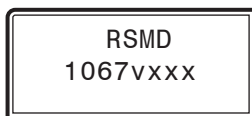

Press  to scroll through REFRIG MODULE screens.

Press  to go to SYSTEM STATUS screens.

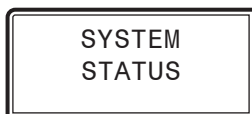

Press  to scroll through SYSTEM STATUS screens.

Press  to go to SENSOR STATUS screens.

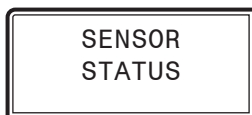

Press  to scroll through SENSOR STATUS screens.

Press  to go to ALARMS screens.

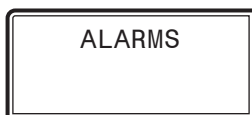

Press  to scroll through ALARMS screens.

Press  to go to ALARM HISTORY screens.



Press  to scroll through ALARM HISTORY screens.

Press  to go to SETPOINT STATUS screens.



Press  to scroll through SETPOINT STATUS screens.

Module Screens

Refer to the following map when navigating through the RSMD-CM Screens. From the RSMD-CM Screen, press **<ENTER>** to scroll through the screens.

RSMD
1067vxxx



EBUS COMM
PACKETS

E-BUS COMMUNICATION DIAGNOSTICS
Number of COMM packets received.



SOFTWARE
1067vXXX



CURRENT SOFTWARE VERSION
You can access the protected screens from this screen by holding the **<UP>** button for five seconds.



BOARD / EBUS
ADDRESS

CURRENT BOARD ADDRESS



#COMP
CONFIGURED

OF COMPRESSORS CONFIGURED



#COND
CONFIGURED

OF CONDENSERS CONFIGURED



COMP A1 - B1
FIXED OR DIG

COMPRESSOR A1 or B1 - FIXED or DIGITAL



COMP A2 - B2
FIXED OR DIG

COMPRESSOR A2 or B2 - FIXED or DIGITAL

System Status Screens

System Status Screens

Refer to the following map when navigating through the System Status Screens. From the SYSTEM STATUS Screen, press <ENTER> to scroll through the screens.

SYSTEM
STATUS



MODE OF
OPERATION

SYSTEM MODE OF OPERATION
Possible Choices are:
OFF, COOL, HEAT, DEHUMID, FORCE



COMP A1 - B1
OFF /
MODULATING %

COMPRESSOR A1, B1
(based on board address)
OFF / MOD POSITION
OFF: Compressor is off.
MODULATING PERCENTAGE: 0-100%



COMP A2 - B2
ON/OFF

COMPRESSOR A2, B2
(based on board address)
ON, OFF, FORCED
OFF: Compressor is off.
ON: Compressor is on.



COND 1 FAN
OFF /
MODULATING %

CONDENSER FAN 1
OFF / MOD POSITION
OFF: Condenser is off.
MODULATING PERCENTAGE: 0-100%



COND 2 FAN
OFF /
MODULATING %

CONDENSER FAN 2
OFF / MOD POSITION
OFF: Condenser is off.
MODULATING PERCENTAGE: 0-100%



BYPS VLV
CLOSED OR
% VALVE

WATERSIDE ECONOMIZER BYPASS VALVE
CLOSED or MOD POSITION
CLOSED: Valve is closed.
VALVE PERCENTAGE: 0-100%



DEFROST
MINUTES

DEFROST INTERVAL TIMER
of MINUTES
OR
If configured for Water Source Heat Pump

H2O FLOW
YES/NO

WATER FLOW
YES/NO

Sensor Status Screens

Refer to the following map when navigating through the Sensor Status Screens. From the SENSOR STATUS Screen, press <ENTER> to scroll through the screens.

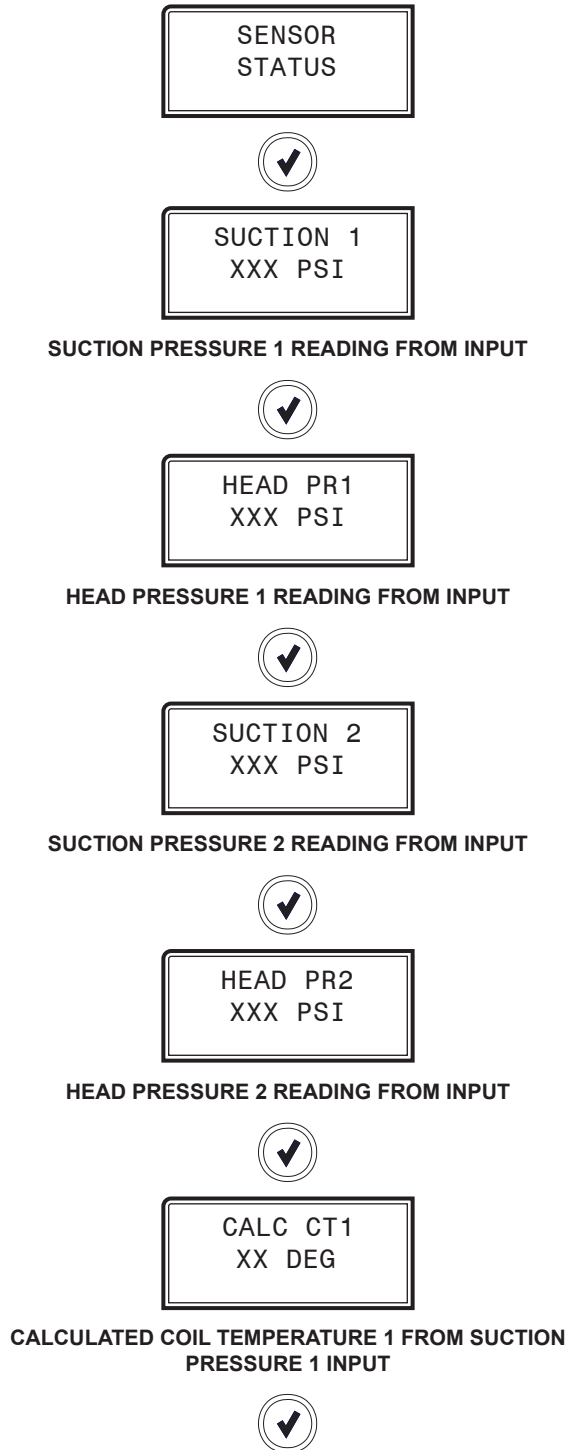

SUCTION PRESSURE 1 READING FROM INPUT

HEAD PRESSURE 1 READING FROM INPUT

SUCTION PRESSURE 2 READING FROM INPUT

HEAD PRESSURE 2 READING FROM INPUT

CALCULATED COIL TEMPERATURE 1 FROM SUCTION PRESSURE 1 INPUT

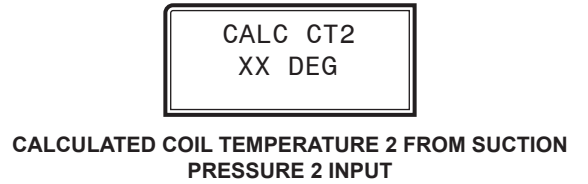

CALCULATED COIL TEMPERATURE 2 FROM SUCTION PRESSURE 2 INPUT

COMPRESSOR TEMPERATURE 1 READING FROM HEAD PRESSURE 1 INPUT

COMPRESSOR TEMPERATURE 2 READING FROM HEAD PRESSURE 2 INPUT

OR
If configured for Water Source Heat Pump

WATER TEMPERATURE READING FROM LEAVING WATER TEMPERATURE SENSOR

Setpoint Status Screens

Setpoint Status Screens

Refer to the following map when navigating through the Setpoint Status Screens. From the SETPOINT STATUS Screen, press <ENTER> to scroll through the screens.

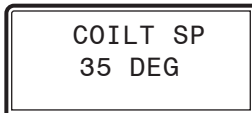

COIL TEMPERATURE SETPOINT STATUS
Valid range is 35°F to 70°F. Default is 35°F.

IF CONFIGURED FOR MODULATING CONDENSER, THE FOLLOWING SCREEN WILL DISPLAY

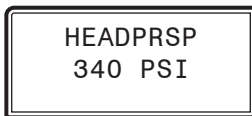

HEAD PRESSURE SETPOINT STATUS
Valid range is 275 to 475 psi. Default is 340 psi.

IF CONFIGURED FOR FAN CYCLE, THE FOLLOWING TWO SCREENS WILL DISPLAY

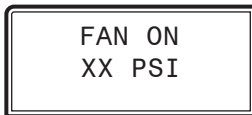

HEAD PRESSURE READING WHEN FAN CYCLE IS ON

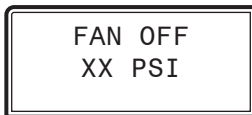

HEAD PRESSURE READING WHEN FAN CYCLE IS OFF

IF CONFIGURED WATER SOURCE HEAT PUMP, THE FOLLOWING THREE SCREENS WILL DISPLAY

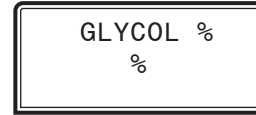

GLYCOL PERCENTAGE STATUS

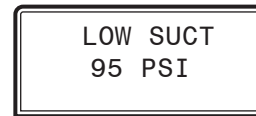

LOW SUCTION PRESSURE SETPOINT STATUS
Default is 95 psi.

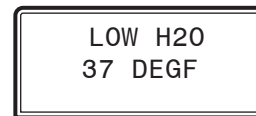

LOW LEAVING WATER TEMPERATURE SETPOINT STATUS
Default is 37°F.

IF CONFIGURED FOR AIR TO AIR HEAT PUMP, THE FOLLOWING SCREEN WILL DISPLAY



DEFROST INTERVAL SETPOINT STATUS
Default is 30 minutes.

Alarms Screen

If an alarm is present, the ALARM LED above the LCD display will light up red and blink. The Alarms will display and scroll automatically from the ALARMS screen when alarms are present.



The alarms are as follows:

NO ALARMS: This will be shown if there are no current alarms.

EBUS SLAVE (SLV) TIMEOUT: This alarm indicates that communication has been lost between the RSMD-CM and the Main controller or other E-BUS modules that may be connected. This can be the result of a bad cable, a missing cable, or the module not being configured properly.

NO SUCTION PRESSURE TRANSDUCER 1 (SUCT1) DETECTED: This alarm indicates the Suction Pressure Transducer 1 is not detected by the system. There is no compressor failure from this alarm. The failure will be unsafe suction pressure.

NO SUCTION PRESSURE TRANSDUCER 2 (SUCT2) DETECTED: This alarm indicates the Suction Pressure Transducer 2 is not detected by the system. There is no compressor failure from this alarm. The failure will be unsafe suction pressure.

NO HEAD PRESSURE TRANSDUCER 1 (HEAD1) DETECTED: This alarm indicates the Head Pressure Transducer 1 is not detected by the system. This will cause the condenser fan/valve to go to 100%.

NO HEAD PRESSURE TRANSDUCER 2 (HEAD2) DETECTED: This alarm indicates the Head Pressure Transducer 2 is not detected by the system. This will cause the condenser fan/valve to go to 100%.

HIGH HEAD PRESSURE 1 (HP1) DETECTED: This alarm indicates when the Head Pressure 1 rises above 550 psig. This will cause the condenser to go to 100%.

HIGH HEAD PRESSURE 2 (HP2) DETECTED: This alarm indicates when the Head Pressure 2 rises above 550 psig. This will cause the condenser to go to 100%.

LOW SUCTION PRESSURE 1 (SP1) FAILURE: This alarm will occur if Suction Pressure 1 stays below the Low Suction Pressure Setpoint for one minute or falls below 40 psi for five seconds. This alarm will shut down the system. Power must be cycled to clear the alarm.

LOW SUCTION PRESSURE 2 (SP2) FAILURE: This alarm will occur if Suction Pressure 2 stays below the Low Suction Pressure Setpoint for one minute or falls below 40 psi for five seconds. This alarm will shut down the system. Power must be cycled to clear the alarm.

LOW SUCTION PRESSURE 1 (SP1) DETECTED: This alarm will occur if Suction Pressure 1 falls below the Low Suction Pressure Setpoint for 20 seconds. The system will try to protect itself by lowering compressor modulation percentage.

LOW SUCTION PRESSURE 2 (SP2) DETECTED: This alarm will occur if Suction Pressure 2 falls below the Low Suction Pressure Setpoint for 20 seconds. The system will try to protect itself by lowering compressor modulation percentage.

COMPRESSOR 1 (COMP1) HPS FAULT: This alarm occurs if the relay is energized and the binary input is energized but the binary input de-energizes within the first 15 minutes of the compressor call. The module allows four retries but locks out on the fifth fault. This sequence is intended to help the startup of units with microchannel coils and prevent nuisance lockouts when the coil is cold. If a fault occurs after the first 15 minutes of the compressor call, the module will allow one retry, and will lock out if another fault occurs within two hours. If any faults have occurred, but the module is not locked out, the fault counter will reset to zero if the RSMD-CM goes to Off Mode OR the compressor has run successfully for two hours since the last fault.

COMPRESSOR 1 (COMP1) FAULT: If the relay energizes but the binary input never energizes, this alarm occurs if the compressor fails to run 45 seconds after the relay is activated. This causes an alarm and de-energizes the compressor enable relay. The system will retry after five minutes.

COMPRESSOR 2 (COMP2) FAULT (if wired in tandem): If the relay energizes but the binary input never energizes: This alarm occurs if the compressor fails to run 45 seconds after the relay is activated. This causes an alarm and shuts down the compressor (relay). The system will retry after five minutes.

COMPRESSOR 2 (COMP2) HPS FAULT (if not in tandem): If the relay is energized and the binary input is also energized: If the binary input de-energizes within the first 15 minutes of the compressor call, the module will allow four retries, and will lock out on the fifth fault. This sequence is intended to help the startup of units with microchannel coils and prevent nuisance lockouts when the coil is cold. If a fault occurs after the first 15 minutes of the compressor call, the module will allow one retry, and will lock out if another fault occurs within two hours. If any faults have occurred, but the module is not locked out, the fault counter will reset to zero if the RSMD-CM goes to Off Mode OR the compressor has run successfully for two hours since the last fault.

Alarms Screens

COMPRESSOR 2 (COMP2) FAULT (if not in tandem): If the relay energizes but the binary input never energizes, this alarm occurs if the compressor fails to run 45 seconds after the relay is activated. This causes an alarm and de-energizes the compressor enable (relay). The system will retry after five minutes.

COMPRESSOR 1 (COMP1) BAD TEMPERATURE: This alarm will occur if the Discharge Temperature Sensor 1 measures less than -40°F or more than 356°F. This causes an alarm and de-energizes the compressor enable (relay).

COMPRESSOR 2 (COMP2) BAD TEMPERATURE: This alarm will occur if the Discharge Temperature Sensor 2 measures less than -40°F or more than 356°F. This causes an alarm and de-energizes the compressor enable (relay). The system will retry after five minutes.

COMPRESSOR 1 (COMP1) CUTOFF: This alarm will occur if the Discharge Temperature Sensor 1 measures more than 265°F. This causes an alarm and de-energizes the compressor enable (relay). The system will can be restarted after 30 minutes.

COMPRESSOR 2 (COMP2) CUTOFF: This alarm will occur if the Discharge Temperature Sensor 2 measures more than 265°F. This will cause an alarm and will shut down the compressor (relay). The system will can be restarted after 30 minutes.

COMPRESSOR (COMP) 1 or 2 LOCKOUT: If active cutoff occurs five times within a four-hour period, the compressor will be locked out. Power must be cycled and the compressor restarted to clear the alarm.

- If a circuit's Suction Pressure twice within a two-hour window falls below the Low Suction Pressure Setpoint for longer than one minute, the compressor on that circuit will be locked out. Manual reset or change of mode is required to return to normal operation.
- If the Suction Pressure falls below the Unsafe Suction Setpoint for five seconds, that circuit's compressor will be locked out. Power will need to be cycled to restart the unit.
- If the Leaving Water Temperature falls below the setpoint, the last compressor will be locked out until the Leaving Water Temperature rises 6°F above setpoint.
- The Leaving Water Temperature remains below the setpoint for one minute or falls 3°F below the setpoint. This alarm will disable when the Leaving Water Temperature rises 12°F above the setpoint.

NO PROOF OF WATER FLOW: This alarm occurs when there is a call for a compressor and the Proof of Flow input is off for more than three minutes or, if during Heat Pump heating mode, the Proof of Flow input is open for more than two seconds. This alarm will disable when the Proof of Flow is enabled.

LOW WATER TEMPERATURE: If both compressors are on and water temperature goes below the setpoint, Compressor 2 will fail. If both compressors are on and water temperature goes 3°F below the setpoint, both compressors will fail. If Compressor 2 is off or failed and water temperature is still low for one minute, the Compressor 1 will also fail. This alarm will disable when the leaving water temperature rises 6°F above the setpoint.

EMERGENCY SHUTDOWN: If the Emergency Shutdown binary input is not activated, the compressors will shut off.

COMPRESSOR 1 FALSE ACTIVE INPUT: If the compressor relay is off but the compressor status binary input is activated for 60 seconds, it will cause an alarm.

COMPRESSOR 2 FALSE ACTIVE INPUT: If the compressor relay is off but the compressor status binary input is activated for 60 seconds, it will cause an alarm.

WSHP HEATING OUT OF ENVELOPE FAULT: If the circuit is running below the envelope consecutively for one minute, the compressor(s) on the circuit will fail and an alarm will be generated. The system will retry after five minutes.

Alarms History Screens and Protected Screens Map

Alarm History Screens

The ALARM HISTORY Screen displays past alarms, if any, and how long ago the last of each type occurred. From the ALARM HISTORY Screen, press <ENTER> to scroll through the history screens.



The Alarm will appear on the first line and the second line will display when each alarm last occurred. As a result, the alarms listed on the ALARMS screen will be abbreviated as follows in order of the way they are listed in the prior ALARMS screen section.

NOTE: The screen will display minutes for the first 60 minutes of alarm occurrence, hours for the next 72 hours of alarm occurrence, and days for the next 30 days of alarm occurrence. After 30 days, the alarms will clear. Alarm history is not stored in memory. So, if power is lost, the alarms will clear.

Protected Screens Map

Refer to the following map when navigating through the LCD Protected Screens. From the RSMD-CM Screen, press <ENTER> twice to get to the Software Screen. Then hold the <UP> button for five seconds. To scroll through the rest of the screens, press the <MENU> button.

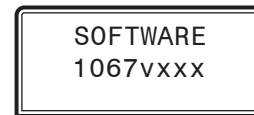
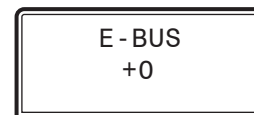
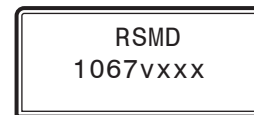

Hold for five seconds.

CONFIG

DIAGNSTC

ALARM
COUNTS

ADDRESS
1 (152)

ENTER TO
EXIT

Configuration Screens

Configuration Screens

Refer to the following map when navigating through the Configuration Screens. From the CONFIG Screen, press **<ENTER>** to scroll through the screens.

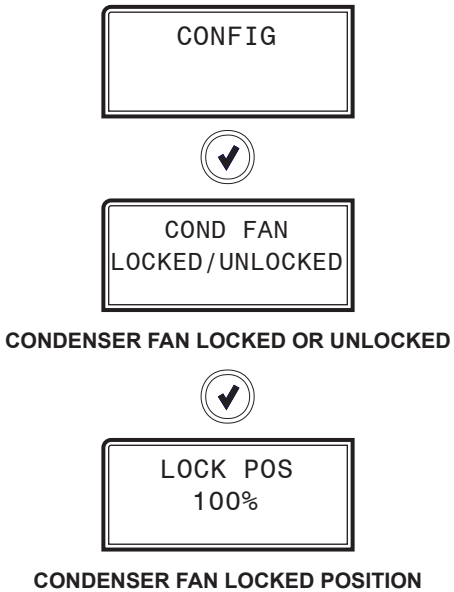

Diagnostic Screens

Refer to the following map when navigating through the Diagnostic Screens. From the DIAGNSTC Screen, press <ENTER> to scroll through the screens.

DIAGNSTC



WDOG CNT
#

WATCHDOG TIMER

Displays the number of times the board has been reset due to watchdog timer overview.



POWR CNT
#

POWER LOSS COUNT

Displays the number of times the board has been reset due to power loss.



EPROM:
HOLD

DOWN
TO

LOAD
DEFAULTS



SP-1 VLT
X.XX

SUCTION PRESSURE TRANSDUCER 1 VOLTAGE

Displays the current voltage of the Suction Pressure Transducer 1.



HP-1 VLT
X.XX

HEAD PRESSURE TRANSDUCER 1 VOLTAGE

Displays the current voltage of the Head Pressure Transducer 1.



SP-2 VLT
X.XX

SUCTION PRESSURE TRANSDUCER 2 VOLTAGE

Displays the current voltage of the Suction Pressure Transducer 2.



HP-2 VLT
X.XX

HEAD PRESSURE TRANSDUCER 2 VOLTAGE

Displays the current voltage of the Head Pressure Transducer 2.



BI 1 - BI 4
ON/OFF

BINARY INPUTS #1 - #4

Displays the current status of each binary input.



TMP1 VLT
X.XX

COIL TEMPERATURE SENSOR 1 VOLTAGE

Displays the current voltage of Coil Temperature Sensor 1.



TMP2 VLT
X.XX

COIL TEMPERATURE SENSOR 2 VOLTAGE

Displays the current voltage of Coil Temperature Sensor 2.



Diagnostic Screens

TMP3 VLT
X.XX

COIL TEMPERATURE SENSOR 3 VOLTAGE

Displays the current voltage of Coil Temperature Sensor 3.



FORCE MODE
ON/OFF

FORCE MODE

Displays the current status of Force Mode. Values are ON/OFF.



IF FORCE MODE IS ON, THE FOLLOWING SCREENS WILL APPEAR:

RLY 1-5
ON/OFF

RELAYS 1-5 FORCE MODE

Press the <UP> or <DOWN> buttons to select ON or OFF for each relay.



TRIAC 1
ON/OFF

TRIAC 1

Displays the current status of Digital Compressor 1. Values are ON/OFF.



TRIAC 2
ON/OFF

TRIAC 2

Displays the current status of Digital Compressor 2. Values are ON/OFF.



AOUT - 1 V
0.0 - 10.0
vdc

CONDENSER SIGNAL 1 FORCE

0.0 to 10.0 = Active Force Mode

Press the <UP> or <DOWN> buttons to increase and decrease the value.



AOUT - 2 V
1.0 - 10.0
vdc

CONDENSER SIGNAL 2 FORCE

0.0 to 10.0 = Active Force Mode

Press the <UP> or <DOWN> buttons to increase and decrease the value.

Alarm Counts Screens

From the ALARM COUNTS Screen, press **<ENTER>** to scroll through the screens. Each screen will display the name of the alarm and how many times the alarm has occurred since you last cleared the alarms. The only way to clear these alarm counts is by using Prism 2 and selecting, “Select Alarms to Delete” from the ALARM button menu. See “Alarm Polling” in the *Prism 2 Technical Guide* for more information.

Address Screen**CURRENT BOARD ADDRESS**

Configure the address according to which refrigerant circuit this module represents—1=A, 2=B, 3=C, 4=D

Number in parentheses is E-BUS address.
Module 1's address is 152, Module 2's address is 153,
Module 3's address is 154, Module 4's address is 155

TROUBLESHOOTING

LED Diagnostics

Using LEDs To Verify Operation

The RSMD-CM is equipped with LEDs that can be used to verify operation and perform troubleshooting. There are LEDs for communication, operation modes, and diagnostic codes. See **Figure 5, this page** for the LED locations. The LEDs associated with these inputs and outputs allow you to see what is active without using a voltmeter. The LEDs and their uses are as follows:

Diagnostic LEDs

STATUS - If the software is running, this LED should blink at a rate of one blink per second.

ALARM (on board) - If the module does not receive communications for more than one minute, this LED will light up, the relays will turn off, and the analog outputs will go to 0 VDC.

ALARM (above LCD display) - This red LED will light up and stay lit when there is an alarm present. The type of alarm will display on the LCD display. The ALARM LED also blinks when the expansion valve is initializing at startup.

COMM - Every time the module receives a valid E-BUS request from the VCCX2 Controller, this LED will blink on and then off, signifying that it received a valid request and responded.

POWER - This LED will light up to indicate that 24 VAC power has been applied to the controller.

Binary Input LEDs

BI1 - This green LED will light up when Compressor Status 1 contact is closed.

BI2 - This green LED will light up when Compressor Status 2 switch is closed.

BI3 - This green LED will light up when the Outdoor Coil Temperature switch is closed.

BI4 - This green LED will light up when the Emergency Shutdown switch is closed.

Relay LEDs

RLY1 - RLY5 - These green LEDs will light up when the relays are enabled and will stay lit as long as they are active.

Digital Compressor LEDs

COMP1 - This green LED will light up when Digital Compressor 1 is unloading.

COMP2 - This green LED will light up when Digital Compressor 2 is unloading.

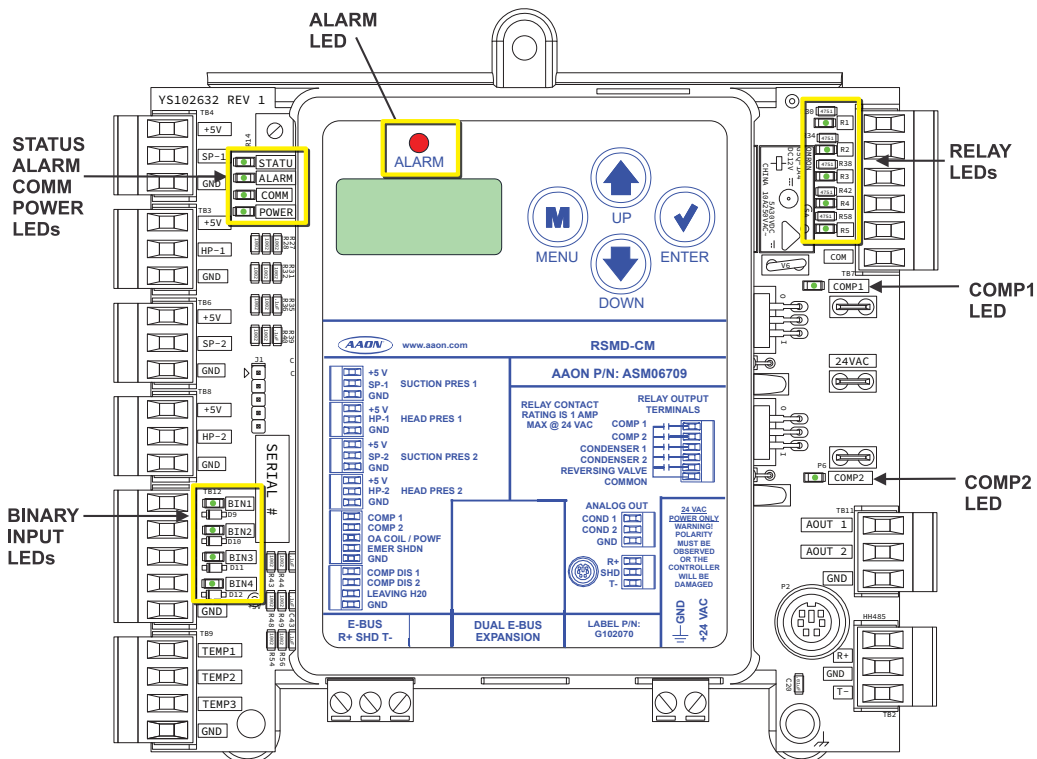

Figure 5: RSMD-CM LED Locations

Suction Pressure Transducer Testing for R410-A Refrigerant

The Evaporator Coil Temperature is calculated by converting the Suction Pressure to temperature. The Suction Pressure is obtained by using the Suction Pressure Transducer, which is connected to the Suction Line of the Compressor.

Use the voltage column to check the Suction Pressure Transducer while connected to the RSMD-CM Module(s). The VCCX2 and the RSMD-CM Module(s) must be powered for this test. Read voltage with the meter set on DC volts. Place the positive lead from the meter on the SP1/SP2 terminal located on the RSMD-CM Module(s) terminal block. Place the negative lead from the meter on the ground (GND) terminal located adjacent to the SP1/SP2 terminal on the RSMD-CM Module(s) terminal block. Use a refrigerant gauge set and/or an accurate electronic thermometer to measure the temperature or suction line pressure near where the Suction Pressure Transducer is connected to the suction line. Measure the voltage at the SP1/SP2 and GND terminals and compare it to the appropriate chart depending on the refrigerant you are using. If the temperature/voltage or pressure/voltage readings do not align closely with the chart, your Suction Pressure Transducer is probably defective and will need to be replaced.

See the Suction Pressure Transducer, Pressure, Temperature, and Voltage Chart for R410-A Refrigerant testing. The chart shows a temperature range from 20°F to 80°F. For troubleshooting purposes, the DC Voltage readings are also listed with their corresponding temperatures and pressures.

Suction Pressure Transducer Coil Pressure – Temperature – Voltage Chart for R410-A Refrigerant			
Temperature °F	Temperature °C	Pressure psi	Signal DC Volts
21.19	-6.1	80.94	1.8
24.49	-4.4	87.16	1.9
27.80	-2.8	93.39	2.0
30.99	-1.1	99.62	2.1
33.89	0.6	105.84	2.2
36.80	2.2	112.07	2.3
39.71	3.9	118.29	2.4
42.30	5.6	124.52	2.5
44.85	6.7	130.75	2.6
47.39	8.3	136.97	2.7
49.94	9.4	143.2	2.8
52.23	11.1	149.42	2.9
54.50	12.2	155.65	3.0
56.76	13.3	161.88	3.1
59.03	15	168.10	3.2
61.17	16.1	174.32	3.3
63.19	17.2	180.55	3.4
65.21	18.3	186.78	3.5
67.23	19.4	193.00	3.6
69.24	20.6	199.23	3.7
71.15	21.7	205.46	3.8
72.95	22.2	211.68	3.9
74.76	23.3	217.91	4.0
76.57	24.4	224.14	4.1
78.37	25.6	230.36	4.2
80.18	26.7	236.59	4.3

**Table 4: Suction Pressure Transducers
Coil Pressure/Temperature/Voltage
Chart for R410-A Refrigerant**

TROUBLESHOOTING

Copeland™ Discharge Thermistor Temperature Sensor Testing

Copeland™ Discharge Thermistor Temperature Sensor Testing

The following sensor voltage and resistance table is provided to aid in checking sensors that appear to be operating incorrectly. Many system operating problems can be traced to incorrect sensor wiring. Be sure all sensors are wired per the wiring diagrams in this manual.

If the sensors still do not appear to be operating or reading correctly, check voltage and/or resistance to confirm that the sensor is operating correctly per the table. Please follow the notes and instructions the appear after the chart when checking sensors.

Thermistor Sensor Testing Instructions

Use the resistance column to check the thermistor sensor while disconnected from the controllers (not powered).

Use the voltage column to check sensors while connected to powered controllers. Read voltage with meter set on DC volts. Place the “-” (minus) lead on GND terminal and the “+” (plus) lead on the sensor input terminal being investigated.

Discharge Thermistor Temperature/Resistance							
Temperature (°F)	Temperature (°C)	Resistance (K Ohms)	Voltage @ Input (VDC)	Temperature (°F)	Temperature (°C)	Resistance (Ohms)	Voltage @ Input (VDC)
-40	-40	2889.60	4.98	167	75	12.73	2.80
-31	-35	2087.22	4.97	176	80	10.79	2.59
-22	-30	1522.20	4.96	185	85	9.20	2.39
-13	-25	1121.44	4.95	194	90	7.87	2.19
-4	-20	834.72	4.94	203	95	6.77	2.01
5	-15	627.28	4.92	212	100	5.85	1.84
14	-10	475.74	4.89	221	105	5.09	1.68
23	-5	363.99	4.86	230	110	4.45	1.53
32	0	280.82	4.82	239	115	3.87	1.39
41	5	218.41	4.77	248	120	3.35	1.25
50	10	171.17	4.72	257	125	2.92	1.12
59	15	135.14	4.65	266	130	2.58	1.02
68	20	107.44	4.57	275	135	2.28	0.92
77	25	86.00	4.47	284	140	2.02	0.83
86	30	69.28	4.36	293	145	1.80	0.76
95	35	56.16	4.24	302	150	1.59	0.68
104	40	45.81	4.10	311	155	1.39	0.61
113	45	37.58	3.94	320	160	1.25	0.55
122	50	30.99	3.77	329	165	1.12	0.50
131	55	25.68	3.59	338	170	1.01	0.45
140	60	21.40	3.40	347	175	0.92	0.42
149	65	17.91	3.20	356	180	0.83	0.38
158	70	15.07	3.00				

NOTE: If the voltage is above 4.98 VDC, then the sensor or wiring is “open.” If the voltage is less than 0.38 VDC, then the sensor or wiring is shorted.

Table 5: Discharge Thermistor Temperature/Resistance

Sensor Voltage and Resistance

The following sensor voltage and resistance table is provided to aid in checking sensors that appear to be operating incorrectly. See **Table 6, this page**. Many system operating problems can be traced to incorrect sensor wiring. Be sure all sensors are wired per the wiring diagrams in this manual.

If the sensors still do not appear to be operating or reading correctly, check voltage and/or resistance to confirm that the sensor is operating correctly per the tables. Please follow the notes and instructions that appear after the chart when checking sensors.

Thermistor Sensor Testing Instructions

Use the resistance column to check the thermistor sensor while disconnected from the controllers (not powered).

Use the voltage column to check sensors while connected to powered controllers. Read voltage with meter set on DC volts. Place the “-” (minus) lead on GND terminal and the “+” (plus) lead on the sensor input terminal being investigated.

Temperature – Resistance – Voltage for Type III 10 K Ohm Thermistor Sensors							
Temperature (°F)	Temperature (°C)	Resistance (Ohms)	Voltage @ Input (VDC)	Temperature (°F)	Temperature (°C)	Resistance (Ohms)	Voltage @ Input (VDC)
-10	-23.3	93333	4.51	72	22.2	11136	2.635
-5	-20.6	80531	4.45	73	22.8	10878	2.605
0	-17.8	69822	4.37	74	23.3	10625	2.576
5	-15	60552	4.29	75	23.9	10398	2.549
10	-12.2	52500	4.2	76	24.4	10158	2.52
15	-9.4	45902	4.1	77	25	10000	2.5
20	-6.6	40147	4.002	78	25.6	9711	2.464
25	-3.9	35165	3.891	80	26.7	9302	2.41
30	-1.1	30805	3.773	82	27.8	8893	2.354
35	1.7	27140	3.651	84	28.9	8514	2.3
40	4.4	23874	3.522	86	30	8153	2.246
45	7.2	21094	3.39	88	31.1	7805	2.192
50	10	18655	3.252	90	32.2	7472	2.139
52	11.1	17799	3.199	95	35	6716	2.009
54	12.2	16956	3.143	100	37.8	6047	1.884
56	13.3	16164	3.087	105	40.6	5453	1.765
58	14.4	15385	3.029	110	43.3	4923	1.65
60	15.6	14681	2.972	115	46.1	4449	1.54
62	16.7	14014	2.916	120	48.9	4030	1.436
64	17.8	13382	2.861	125	51.7	3656	1.339
66	18.9	12758	2.802	130	54.4	3317	1.246
68	20	12191	2.746	135	57.2	3015	1.159
69	20.6	11906	2.717	140	60	2743	1.077
70	21.1	11652	2.691	145	62.7	2502	1.001
71	21.7	11379	2.661	150	65.6	2288	0.931

NOTE: If the voltage is above 4.88 VDC, then the sensor or wiring is “open.” If the voltage is less than 0.05 VDC, then the sensor or wiring is shorted.

Table 6: 0-5V Temperature Sensor - Voltage and Resistance for Type III Sensors

TROUBLESHOOTING

Head Pressure Transducer

If you suspect there is a problem related to the Head Pressure Transducer, voltage and pressure readings can be taken at the HP terminal. See **Table 7, this page.**

Head Pressure Transducer Chart			
Voltage	Pressure	Voltage	Pressure
0.5	0	2.6	350
0.6	17	2.7	367
0.7	33	2.8	384
0.8	50	2.9	400
0.9	67	3.0	417
1.0	83	3.1	434
1.1	100	3.2	450
1.2	117	3.3	467
1.3	133	3.4	484
1.4	150	3.5	500
1.5	167	3.6	517
1.6	183	3.7	534
1.7	200	3.8	550
1.8	217	3.9	567
1.9	233	4.0	584
2.0	250	4.1	600
2.1	267	4.2	617
2.2	283	4.3	634
2.3	300	4.4	650
2.4	317	4.5	667
2.5	334		

Table 7: Head Pressure Transducer Chart

Two Condensers Per Module (Default)

Two Condensers Per Module

See **Figure 6, this page** for Two Condenser Operation wiring. Refer to the figures on the following page for Prism 2 configuration, Modular Service Tool Screen selection, and HVAC unit application.

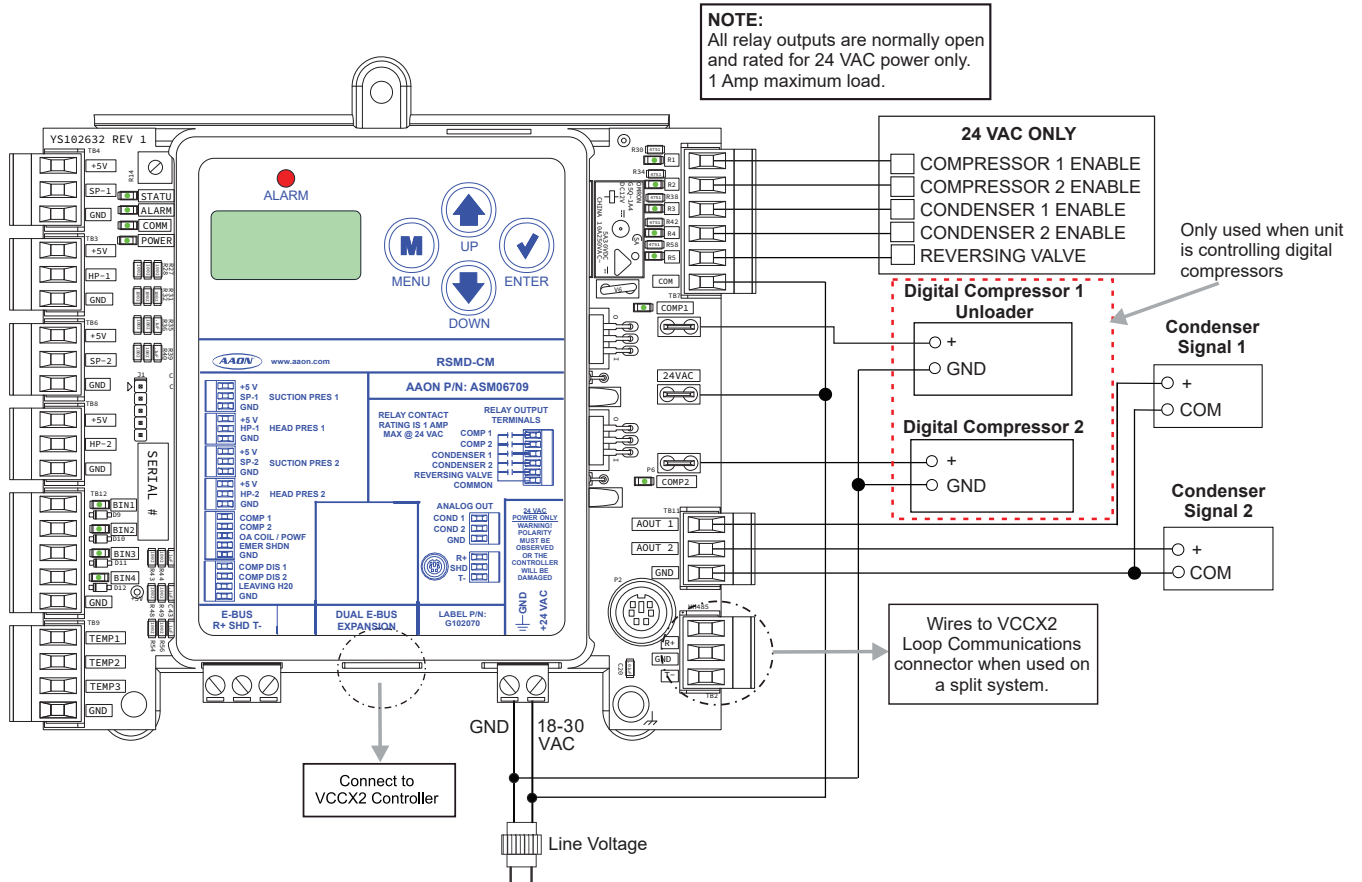

Figure 6: Two Condenser Operation (Default)

APPENDIX A: CONDENSER OPTIONS

Two Condensers Per Module (Default)

RSM-D Configuration

Module Configurations

A	B	C	D
<input type="checkbox"/>	<input type="checkbox"/>	<input type="checkbox"/>	<input type="checkbox"/> Single Compressor { Default = Dual }
<input type="checkbox"/>	<input type="checkbox"/>	<input type="checkbox"/>	<input type="checkbox"/> Comp #1 Fixed { Default = Modulating }
<input type="checkbox"/>	<input type="checkbox"/>	<input type="checkbox"/>	<input type="checkbox"/> Comp #2 Fixed { Default = Modulating }
<input type="checkbox"/>	<input type="checkbox"/>	<input type="checkbox"/>	<input type="checkbox"/> Refrigerant Circuit Tandem { Default = No }
<input type="checkbox"/>	<input type="checkbox"/>	<input type="checkbox"/>	<input type="checkbox"/> Fan Cycle Relay Control { Default = No }
<input type="checkbox"/>	<input type="checkbox"/>	<input type="checkbox"/>	<input type="checkbox"/> Fixed Condenser Fan { Default = Modulating }
<input type="checkbox"/>	<input type="checkbox"/>	<input type="checkbox"/>	<input type="checkbox"/> Copeland 2 Stage Compressor
<input type="checkbox"/>	<input type="checkbox"/>	<input type="checkbox"/>	<input type="checkbox"/> Single Compressor Startup { Default = Dual }
<input type="checkbox"/>	<input type="checkbox"/>	<input type="checkbox"/>	<input type="checkbox"/> Water Side Economizer Operation

Digital Compressor Safety Setpoints

Safety Stage Off Position

Safety Stage Off Period

Configuration

Configuration Index Altitude

Unit Tonnage Invalid Tonnage!

Outdoor Coil Approach Temp

Emergency Shutdown Input

Condenser Configurations

- Two Condenser Outputs Per Module
- Single Condenser Output Per Module
- Single Condenser Output Per Two Modules
- Single Condenser Output for Three Modules
- A1/B1 and A2/B2 Condenser
- Single Condenser Output for Four Modules

Modulating HPC Setpoints

Air to Air Heat Pumps and Standard Units

Cooling Mode Head Pressure

Reheat Mode Head Pressure

Water Source Heatpumps

Cooling Mode Head Pressure

Reheat Mode Head Pressure

Min Water Valve Position

On/Off Fan Cycle

Fan Cycle Enable Setpoint

Fan Cycle Deadband

Fan Cycle Reheat Offset

Figure 7: Prism 2 Condenser Configuration - Two Condenser Operations (Default)

HVAC Unit Application

The default Two Condensers Per Module configuration is used with the following HVAC units:

- B-BOX
- C-BOX 16-20 Ton
- D-BOX 26-40 Ton

Single Condenser Per Module

See **Figure 8, this page** for Single Condenser Per Module wiring. Refer to the figures on the following page for Prism 2 configuration, Modular Service Tool Screen selection, and HVAC unit application.

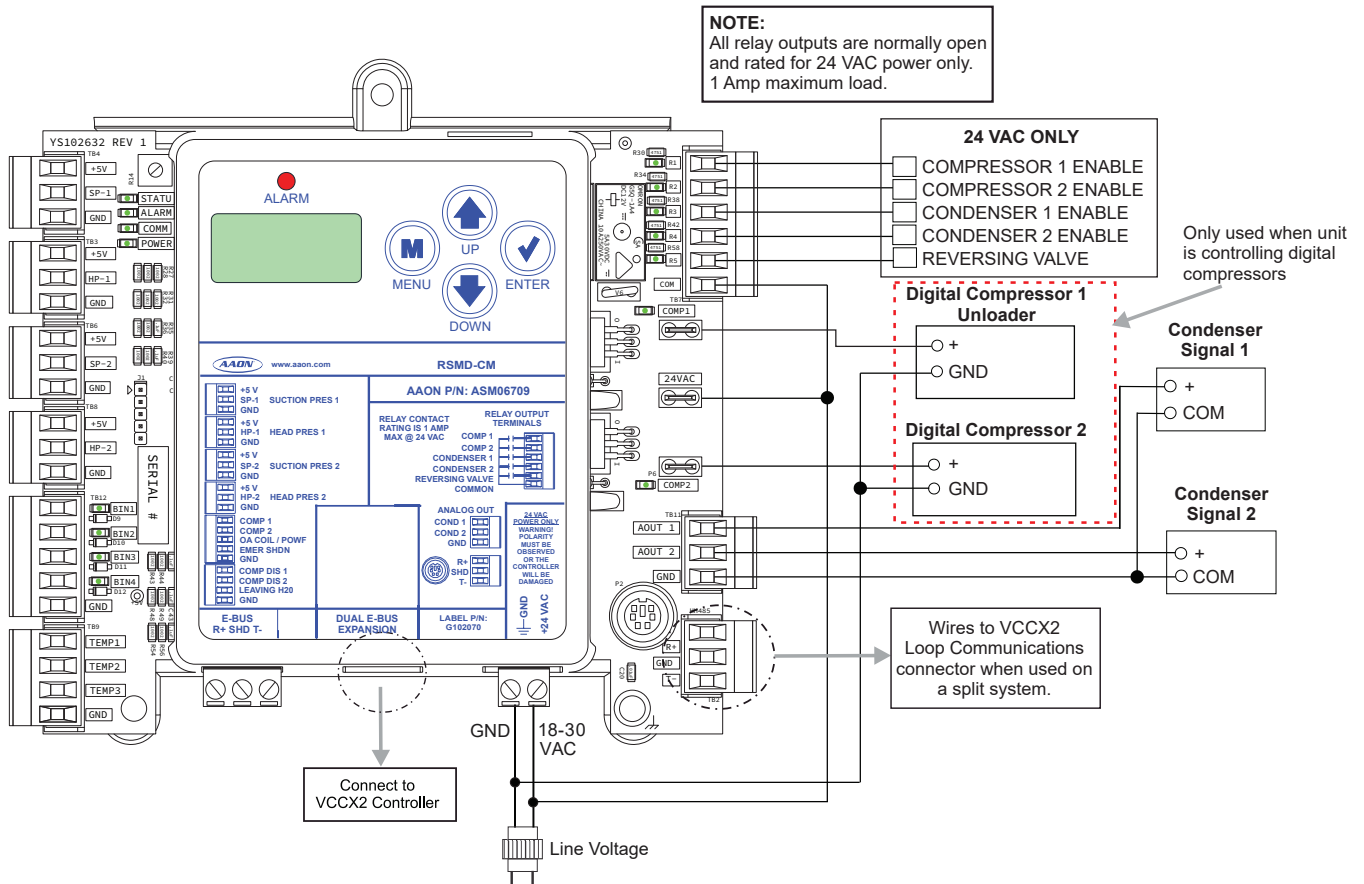

Figure 8: Single Condenser Per Module

APPENDIX A: CONDENSER OPTIONS

Single Condenser Per Module

The screenshot displays the RSM-D Configuration interface. The 'Condenser Configurations' section is highlighted with a yellow border and contains the following options:

- Two Condenser Outputs Per Module
- Single Condenser Output Per Module
- Single Condenser Output Per Two Modules
- Single Condenser Output for Three Modules
- A1/B1 and A2/B2 Condenser
- Single Condenser Output for Four Modules

The 'Module Configurations' section includes a grid for modules A, B, C, and D, and a list of options:

- Single Compressor { Default = Dual }
- Comp #1 Fixed { Default = Modulating }
- Comp #2 Fixed { Default = Modulating }
- Refrigerant Circuit Tandem { Default = No }
- Fan Cycle Relay Control { Default = No }
- Fixed Condenser Fan { Default = Modulating }
- Copeland 2 Stage Compressor
- Single Compressor Startup { Default = Dual }
- Water Side Economizer Operation

The 'Digital Compressor Safety Setpoints' section includes:

- Safety Stage Off Position
- Safety Stage Off Period

The 'Configuration' section includes:

- Configuration Index
- Unit Tonnage Invalid Tonnage!
- Altitude
- Outdoor Coil Approach Temp
- Emergency Shutdown Input

The 'Modulating HPC Setpoints' section includes:

- Air to Air Heat Pumps and Standard Units**
 - Cooling Mode Head Pressure
 - Reheat Mode Head Pressure
- Water Source Heatpumps**
 - Cooling Mode Head Pressure
 - Reheat Mode Head Pressure
- Min Water Valve Position

The 'On/Off Fan Cycle' section includes:

- Fan Cycle Enable Setpoint
- Fan Cycle Deadband
- Fan Cycle Reheat Offset

Figure 9: Prism 2 Condenser Configuration - Single Condenser Per Module

HVAC Unit Application

The Single Condenser Per Module configuration is used with the following HVAC units:

- B-BOX Air to Air Heat Pump
- B-BOX WSHP
- C-BOX 25-30 Ton
- C-BOX Air to Air Heat Pump
- C-BOX WSHP

Single Condenser Per Two Modules

See **Figure 10, this page** for single condenser per two modules wiring. Refer to the figures on the following page for Prism 2 configuration, Modular Service Tool Screen selection, and HVAC unit application.

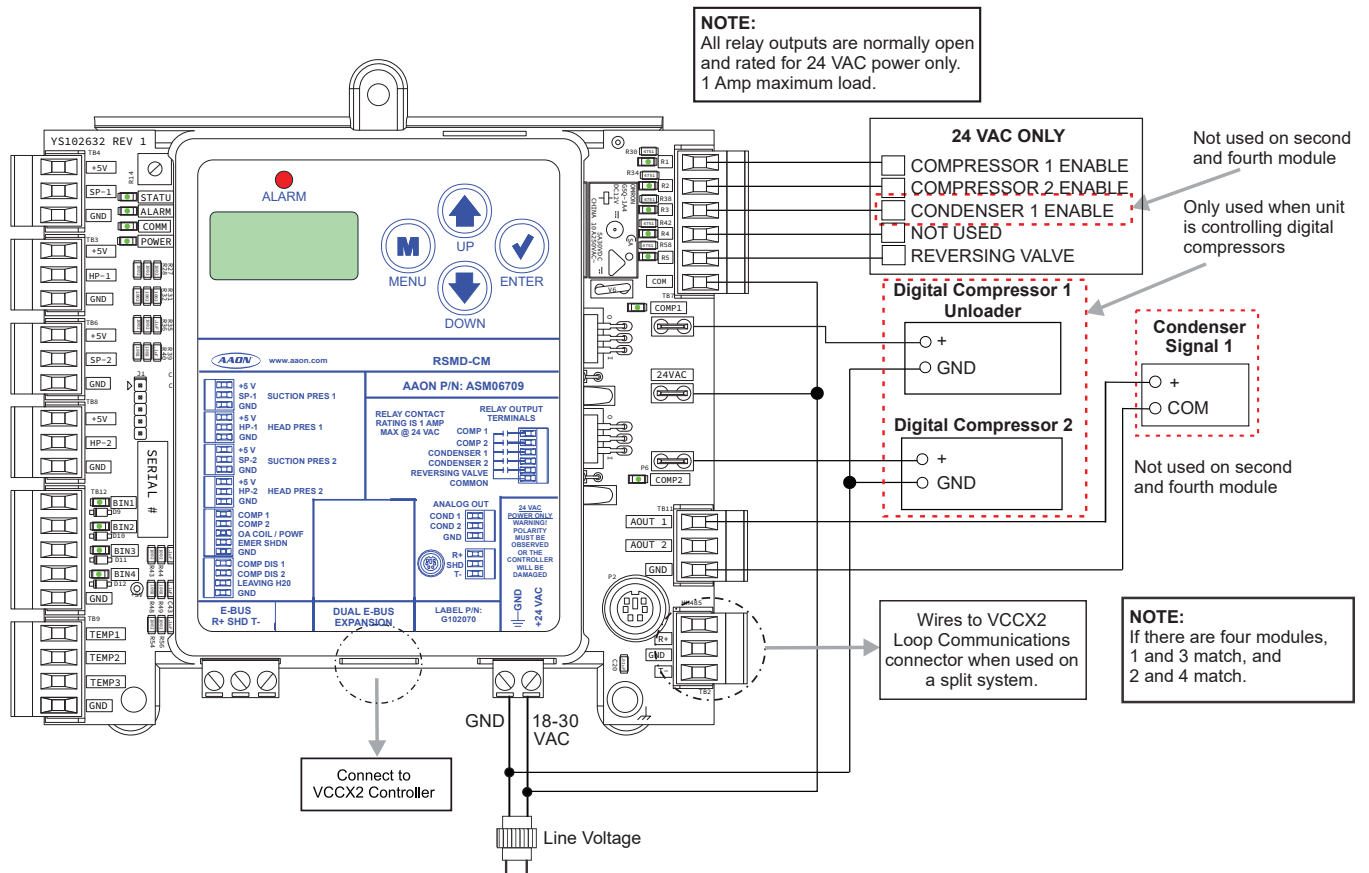

Figure 10: Single Condenser Per Two Modules

APPENDIX A: CONDENSER OPTIONS

Single Condenser Per Two Modules

The screenshot displays the 'RSM-D Configuration' interface. The 'Condenser Configurations' section is highlighted with a yellow border and contains the following radio button options:

- Two Condenser Outputs Per Module
- Single Condenser Output Per Module
- Single Condenser Output Per Two Modules
- Single Condenser Output for Three Modules
- A1/B1 and A2/B2 Condenser
- Single Condenser Output for Four Modules

The 'Module Configurations' section includes a grid for modules A, B, C, and D, and a list of options with their default values:

Module	Option	Default
A	Single Compressor	Dual
A	Comp #1 Fixed	Modulating
A	Comp #2 Fixed	Modulating
A	Refrigerant Circuit Tandem	No
A	Fan Cycle Relay Control	No
A	Fixed Condenser Fan	Modulating
A	Copeland 2 Stage Compressor	
A	Single Compressor Startup	Dual
A	Water Side Economizer Operation	

The 'Digital Compressor Safety Setpoints' section includes input fields for 'Safety Stage Off Position' and 'Safety Stage Off Period'. The 'Configuration' section includes input fields for 'Configuration Index', 'Unit Tonnage', 'Altitude', 'Outdoor Coil Approach Temp', and a checkbox for 'Emergency Shutdown Input'. The 'Modulating HPC Setpoints' section includes input fields for 'Cooling Mode Head Pressure' and 'Reheat Mode Head Pressure' for both 'Air to Air Heat Pumps and Standard Units' and 'Water Source Heatpumps'. The 'On/Off Fan Cycle' section includes input fields for 'Fan Cycle Enable Setpoint', 'Fan Cycle Deadband', and 'Fan Cycle Reheat Offset'.

Figure 11: Prism 2 Condenser Configuration - Single Condenser Per Two Modules

HVAC Unit Application

The Single Condenser Per Two Modules configuration is used with the following HVAC units:

- RLA BOX
- RLB BOX
- RLE BOX

Single Condenser for Three Modules

See **Figure 12, this page** for Single Condenser for Three Modules wiring. Refer to the figures on the following page for Prism 2 configuration, Modular Service Tool Screen selection, and HVAC unit application.

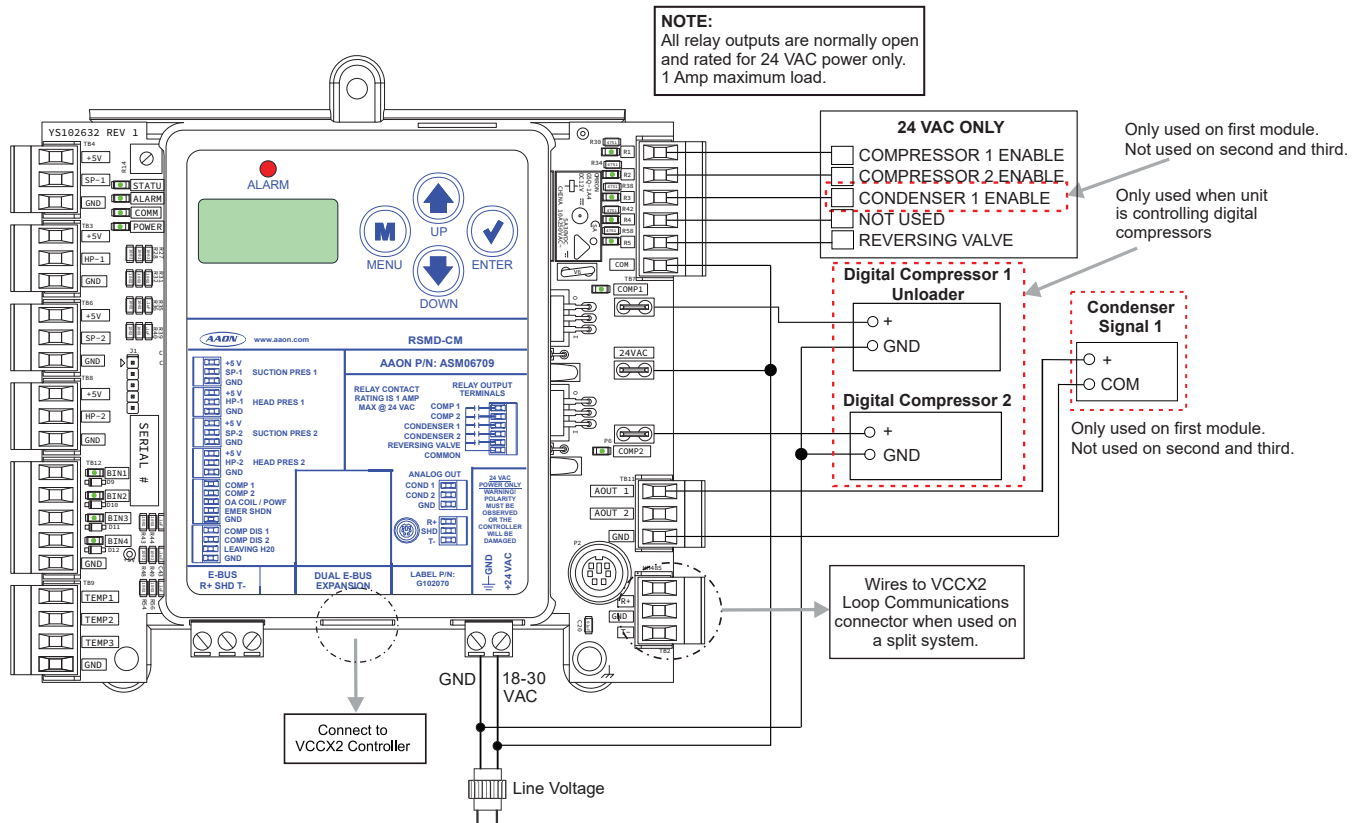

Figure 12: Single Condenser for Three Modules

APPENDIX A: CONDENSER OPTIONS

Single Condenser for Three Modules

The screenshot displays the RSM-D Configuration interface. The 'Condenser Configurations' section is highlighted with a yellow border and contains the following options:

- Two Condenser Outputs Per Module
- Single Condenser Output Per Module
- Single Condenser Output Per Two Modules
- Single Condenser Output for Three Modules
- A1/B1 and A2/B2 Condenser
- Single Condenser Output for Four Modules

The 'Module Configurations' section includes a grid for modules A, B, C, and D, with various options such as 'Single Compressor', 'Comp #1 Fixed', 'Comp #2 Fixed', 'Refrigerant Circuit Tandem', 'Fan Cycle Relay Control', 'Fixed Condenser Fan', 'Copeland 2 Stage Compressor', 'Single Compressor Startup', and 'Water Side Economizer Operation'. The 'Digital Compressor Safety Setpoints' section has input fields for 'Safety Stage Off Position' and 'Safety Stage Off Period'. The 'Configuration' section includes fields for 'Configuration Index', 'Unit Tonnage', 'Altitude', 'Outdoor Coil Approach Temp', and 'Emergency Shutdown Input'. The 'Modulating HPC Setpoints' section has input fields for 'Cooling Mode Head Pressure' and 'Reheat Mode Head Pressure' for both 'Air to Air Heat Pumps and Standard Units' and 'Water Source Heatpumps'. The 'On/Off Fan Cycle' section has input fields for 'Fan Cycle Enable Setpoint', 'Fan Cycle Deadband', and 'Fan Cycle Reheat Offset'.

Figure 13: Prism 2 Condenser Configuration - Single Condenser for Three Modules

HVAC Unit Application

The Single Condenser for Three Modules configuration is used with the following HVAC units:

- RLC BOX
- RLD BOX

A1/B1 and A2/B2 Condenser Configuration

See **Figure 14**, **this page** and **Figure 15**, **page 40** for A1/B1 and A2/B2 wiring. Refer to **Figure 16**, **page 41** for Prism 2 configuration, Modular Service Tool Screen selection, and HVAC unit application.

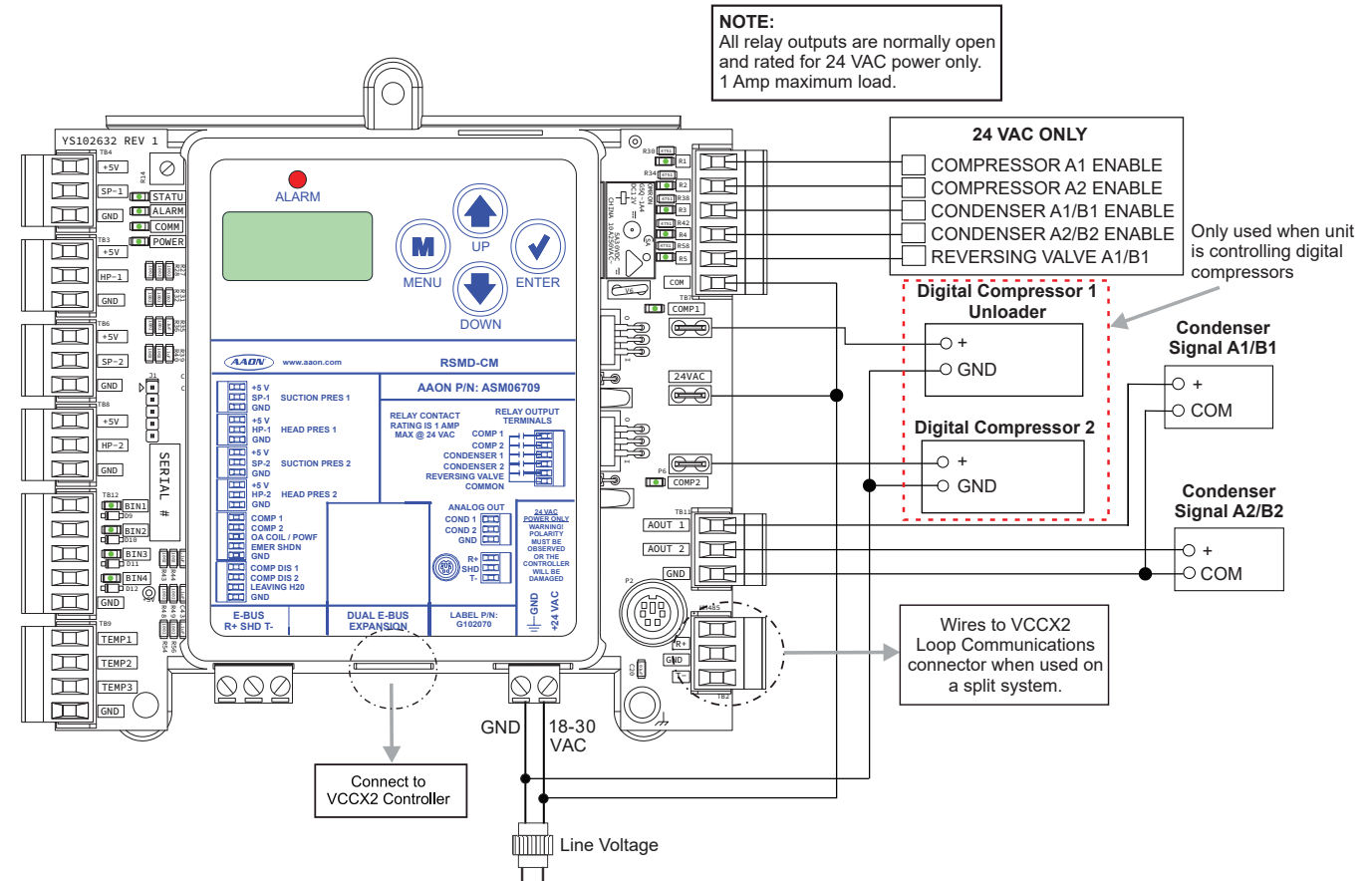

Figure 14: A1/B1 Wiring

APPENDIX A: CONDENSER OPTIONS

A1/B1 and A2/B2 Condenser Configuration

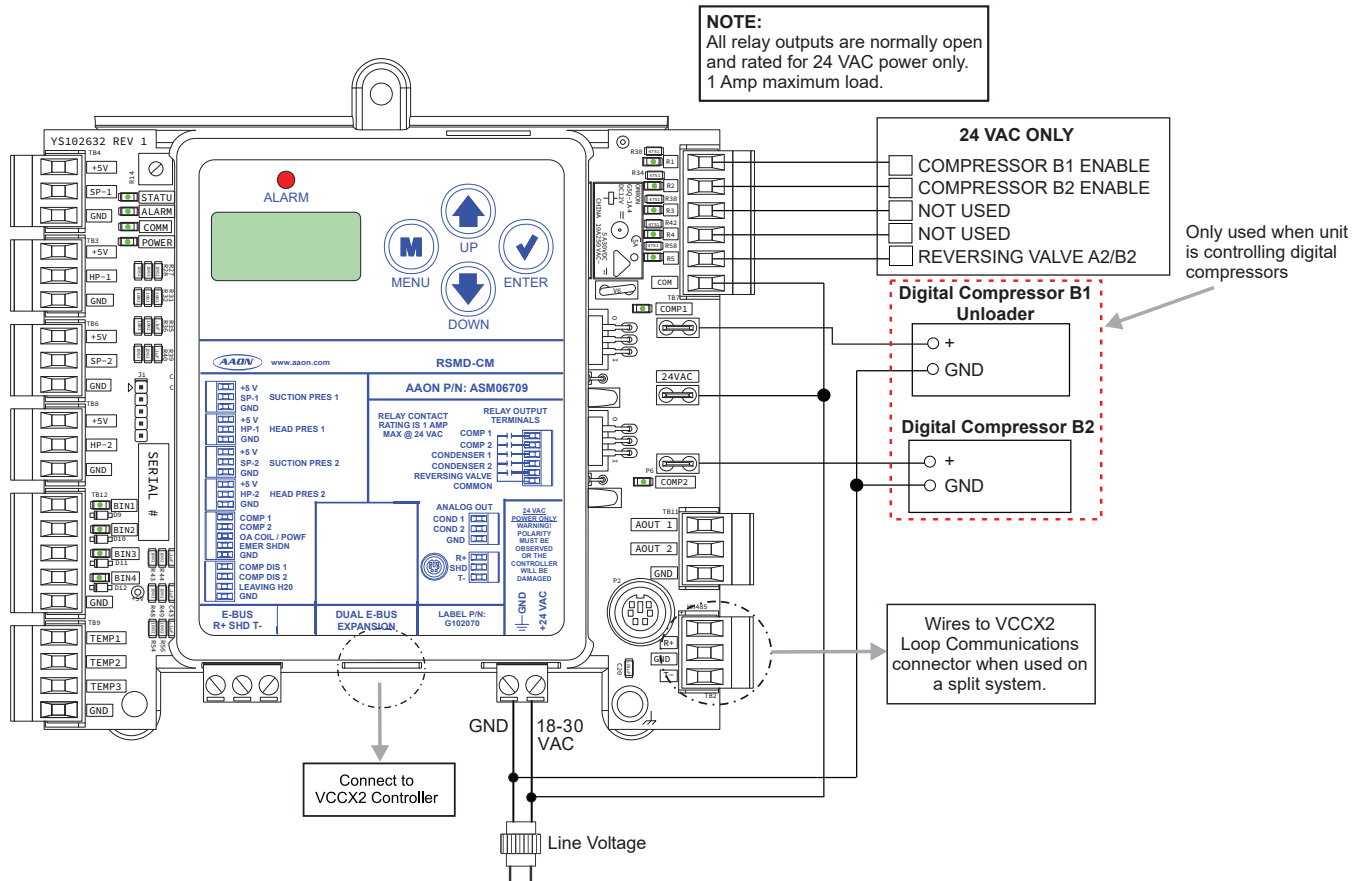

Figure 15: A2/B2 Wiring

RSM-D Configuration

Module Configurations

A	B	C	D		
<input type="checkbox"/>	<input type="checkbox"/>	<input type="checkbox"/>	<input type="checkbox"/>	Single Compressor	{ Default = Dual }
<input type="checkbox"/>	<input type="checkbox"/>	<input type="checkbox"/>	<input type="checkbox"/>	Comp #1 Fixed	{ Default = Modulating }
<input type="checkbox"/>	<input type="checkbox"/>	<input type="checkbox"/>	<input type="checkbox"/>	Comp #2 Fixed	{ Default = Modulating }
<input type="checkbox"/>	<input type="checkbox"/>	<input type="checkbox"/>	<input type="checkbox"/>	Refrigerant Circuit Tandem	{ Default = No }
<input type="checkbox"/>	<input type="checkbox"/>	<input type="checkbox"/>	<input type="checkbox"/>	Fan Cycle Relay Control	{ Default = No }
<input type="checkbox"/>	<input type="checkbox"/>	<input type="checkbox"/>	<input type="checkbox"/>	Fixed Condenser Fan	{ Default = Modulating }
<input type="checkbox"/>	<input type="checkbox"/>	<input type="checkbox"/>	<input type="checkbox"/>	Copeland 2 Stage Compressor	
<input type="checkbox"/>	<input type="checkbox"/>	<input type="checkbox"/>	<input type="checkbox"/>	Single Compressor Startup	{ Default = Dual }
<input type="checkbox"/>	<input type="checkbox"/>	<input type="checkbox"/>	<input type="checkbox"/>	Water Side Economizer Operation	

Condenser Configurations

Two Condenser Outputs Per Module

Single Condenser Output Per Module

Single Condenser Output Per Two Modules

Single Condenser Output for Three Modules

A1/B1 and A2/B2 Condenser

Single Condenser Output for Four Modules

Digital Compressor Safety Setpoints

Safety Stage Off Position

Safety Stage Off Period

Configuration

Configuration Index Altitude

Unit Tonnage Invalid Tonnage!

Outdoor Coil Approach Temp

Emergency Shutdown Input

Modulating HPC Setpoints

Air to Air Heat Pumps and Standard Units

Cooling Mode Head Pressure

Reheat Mode Head Pressure

Water Source Heatpumps

Cooling Mode Head Pressure

Reheat Mode Head Pressure

Min Water Valve Position

On/Off Fan Cycle

Fan Cycle Enable Setpoint

Fan Cycle Deadband

Fan Cycle Reheat Offset

Figure 16: Prism 2 Condenser Configuration - A1/B1 and A2/B2 Condenser Configuration

HVAC Unit Application

The A1/B1 and A2/B2 Condenser configuration is used with the following HVAC units:

- D-BOX 50-70 Ton
- D-BOX Air to Air Heat Pump
- D-BOX WSHP

APPENDIX A: CONDENSER OPTIONS

ON/OFF Condenser Options

RSM-D Configuration

Module Configurations				Condenser Configurations
<input type="checkbox"/>	<input type="checkbox"/>	<input type="checkbox"/>	<input type="checkbox"/> Single Compressor { Default = Dual }	<input checked="" type="radio"/> Two Condenser Outputs Per Module <input type="radio"/> Single Condenser Output Per Module <input type="radio"/> Single Condenser Output Per Two Modules <input type="radio"/> Single Condenser Output for Three Modules <input type="radio"/> A1/B1 and A2/B2 Condenser <input type="radio"/> Single Condenser Output for Four Modules
<input type="checkbox"/>	<input type="checkbox"/>	<input type="checkbox"/>	<input type="checkbox"/> Comp #1 Fixed { Default = Modulating }	
<input type="checkbox"/>	<input type="checkbox"/>	<input type="checkbox"/>	<input type="checkbox"/> Comp #2 Fixed { Default = Modulating }	
<input type="checkbox"/>	<input type="checkbox"/>	<input type="checkbox"/>	<input type="checkbox"/> Refrigerant Circuit Tandem { Default = No }	
<input type="checkbox"/>	<input type="checkbox"/>	<input type="checkbox"/>	<input type="checkbox"/> Fan Cycle Relay Control { Default = No }	
<input type="checkbox"/>	<input type="checkbox"/>	<input type="checkbox"/>	<input type="checkbox"/> Fixed Condenser Fan { Default = Modulating }	
<input type="checkbox"/>	<input type="checkbox"/>	<input type="checkbox"/>	<input type="checkbox"/> Copeland 2 Stage Compressor	
<input type="checkbox"/>	<input type="checkbox"/>	<input type="checkbox"/>	<input type="checkbox"/> Single Compressor Startup { Default = Dual }	
<input type="checkbox"/>	<input type="checkbox"/>	<input type="checkbox"/>	<input type="checkbox"/> Water Side Economizer Operation	

Select this option to have the condenser fan turn on/off with the compressors. This can also be selected when no head pressure control is required.

RSM-D Configuration

Module Configurations				Condenser Configurations
<input type="checkbox"/>	<input type="checkbox"/>	<input type="checkbox"/>	<input type="checkbox"/> Single Compressor { Default = Dual }	<input checked="" type="radio"/> Two Condenser Outputs Per Module <input type="radio"/> Single Condenser Output Per Module <input type="radio"/> Single Condenser Output Per Two Modules <input type="radio"/> Single Condenser Output for Three Modules <input type="radio"/> A1/B1 and A2/B2 Condenser <input type="radio"/> Single Condenser Output for Four Modules
<input type="checkbox"/>	<input type="checkbox"/>	<input type="checkbox"/>	<input type="checkbox"/> Comp #1 Fixed { Default = Modulating }	
<input type="checkbox"/>	<input type="checkbox"/>	<input type="checkbox"/>	<input type="checkbox"/> Comp #2 Fixed { Default = Modulating }	
<input type="checkbox"/>	<input type="checkbox"/>	<input type="checkbox"/>	<input type="checkbox"/> Refrigerant Circuit Tandem { Default = No }	
<input type="checkbox"/>	<input type="checkbox"/>	<input type="checkbox"/>	<input type="checkbox"/> Fan Cycle Relay Control { Default = No }	
<input type="checkbox"/>	<input type="checkbox"/>	<input type="checkbox"/>	<input type="checkbox"/> Fixed Condenser Fan { Default = Modulating }	
<input type="checkbox"/>	<input type="checkbox"/>	<input type="checkbox"/>	<input type="checkbox"/> Copeland 2 Stage Compressor	
<input type="checkbox"/>	<input type="checkbox"/>	<input type="checkbox"/>	<input type="checkbox"/> Single Compressor Startup { Default = Dual }	
<input type="checkbox"/>	<input type="checkbox"/>	<input type="checkbox"/>	<input type="checkbox"/> Water Side Economizer Operation	

Select this option if the condenser fan cycles on/off based on the Fan Cycle Head Pressure Setpoints.

Digital Compressor Safety Setpoints

Safety Stage Off Position

Safety Stage Off Period

Configuration

Configuration Index Altitude

Unit Tonnage Invalid Tonnage!

Outdoor Coil Approach Temp

Emergency Shutdown Input

Modulating HPC Setpoints

Air to Air Heat Pumps and Standard Units

Cooling Mode Head Pressure

Reheat Mode Head Pressure

Water Source Heatpumps

Cooling Mode Head Pressure

Reheat Mode Head Pressure

Min Water Valve Position

On/Off Fan Cycle

0 PSI Fan Cycle Enable Setpoint

0 PSI Fan Cycle Deadband

0 PSI Fan Cycle Reheat Offset

Figure 17: Prism 2 Condenser Configuration - ON/OFF Condenser Options

RSMD-CM Technical Guide

G102430 · Rev. A · 211222

AAON Controls Support:
Support.Controls@aaon.com

Controls Support Website:
www.aaon.com/aaon-controls-technical-support

AAON Factory Technical Support:
Technical.Support@aaon.com

Phone

866-918-1100

Monday through Friday, 7:00 AM to 5:00 PM Central Time

NOTE: Before calling Technical Support, please have the model and serial number of the unit available.

PARTS: For replacement parts, please contact your local AAON Representative.

Are you an AAON Rep?

You can visit My AAON to open new support tickets, communicate directly with our support teams, and track your support progress easily from one place!



2425 South Yukon Ave • Tulsa, OK • 74107-2728
Ph: (918) 583-2266 • Fax: (918) 583-6094
AAON P/N: G102430, Rev. A

Printed in the USA • Copyright December 2021 • All Rights Reserved