



# RZ SERIES

(45-240 tons)

Packaged Rooftop Units & Outdoor Air Handling Units



## Installation, Operation, & Maintenance



### WARNING

#### FIRE OR EXPLOSION HAZARD

Failure to follow safety warnings exactly could result in serious injury, death or property damage.

Be sure to read and understand the installation, operation and service instructions in this manual.

Improper installation, adjustment, alteration, service or maintenance can cause serious injury, death or property damage.

A copy of this IOM must be kept with the unit.

### WARNING

- Do not store gasoline or other flammable vapors and liquids in the vicinity of this or any other appliance
- WHAT TO DO IF YOU SMELL GAS
  - Do not try to light any appliance.
  - Do not touch any electrical switch; do not use any phone in your building.
  - Leave the building immediately.
  - Immediately call your gas supplier from a phone remote from the building. Follow the gas supplier's instructions.
  - If you cannot reach your gas supplier, call the fire department.
- Startup and service must be performed by a Factory Trained Service Technician competent in working with flammable refrigerants.



# Table of Contents

## Contents

<b>TABLE OF CONTENTS.....</b>	<b>3</b>
<i>Index of Tables and Figures.....</i>	<i>6</i>
<i>Tables.....</i>	<i>6</i>
<i>Figures.....</i>	<i>7</i>
AAON® RZ SERIES FEATURES AND OPTIONS INTRODUCTION .....	8
<i>Indoor Air Quality.....</i>	<i>8</i>
<i>Humidity Control.....</i>	<i>8</i>
<i>Safety.....</i>	<i>8</i>
<i>Installation and Maintenance.....</i>	<i>8</i>
<i>System Integration.....</i>	<i>8</i>
<i>Environmentally Friendly.....</i>	<i>8</i>
<i>Extended Life.....</i>	<i>8</i>
RZ SERIES FEATURE STRING NOMENCLATURE .....	16
<i>RZ Series Feature String Nomenclature .....</i>	<i>17</i>
<i>RZ Series Feature String Nomenclature .....</i>	<i>18</i>
<i>RZ Series Feature String Nomenclature .....</i>	<i>19</i>
<i>RZ Series Feature String Nomenclature .....</i>	<i>20</i>
<i>RZ Series Feature String Nomenclature .....</i>	<i>21</i>
<i>RZ Series Feature String Nomenclature .....</i>	<i>22</i>
<i>RZ Series Feature String Nomenclature .....</i>	<i>23</i>
<i>RZ Series Feature String Nomenclature .....</i>	<i>24</i>
<i>RZ Series Feature String Nomenclature .....</i>	<i>25</i>
<i>RZ Series Feature String Nomenclature .....</i>	<i>26</i>
<i>RZ Series Feature String Nomenclature .....</i>	<i>27</i>
GENERAL INFORMATION .....	30
<i>Certification of Gas Heat Models.....</i>	<i>30</i>
<i>Certification of Steam or Hot Water Heat Models.....</i>	<i>30</i>
<i>Certification of Electric Heat Models.....</i>	<i>30</i>
<i>Certification of Cooling Models.....</i>	<i>30</i>
<i>Codes and Ordinances.....</i>	<i>31</i>
<i>Receiving Unit.....</i>	<i>31</i>
<i>Storage.....</i>	<i>30</i>
<i>Access Doors.....</i>	<i>30</i>
<i>Wiring Diagrams.....</i>	<i>30</i>
INSTALLATION.....	30
<i>Locating Units.....</i>	<i>30</i>
<i>Curb Installation.....</i>	<i>31</i>
<i>Lifting the Unit.....</i>	<i>32</i>
<i>Lifting slot locations are unit specific.....</i>	<i>34</i>
<i>Duct Connection.....</i>	<i>35</i>
<i>Reassembling Split Units.....</i>	<i>36</i>
<i>Outside Air Rain Hood.....</i>	<i>38</i>
<i>End Flashing Installation.....</i>	<i>38</i>
<i>Vestibule Exhaust Fan.....</i>	<i>39</i>
<i>Motorized Exhaust &amp; Rain Hood.....</i>	<i>39</i>

Electrical.....	40
Condensate Drain Piping.....	42
Draw-Through Coils .....	43
Blow-Through Coils .....	44
STARTUP (SEE BACK OF THE MANUAL FOR STARTUP FORM) .....	45
Filters .....	45
Airflow Balancing and Checking.....	46
Air Flow Monitoring .....	46
Supply, Return, and Exhaust Backward Curved Fans .....	46
Back Draft Damper Setup .....	48
Adjusting Refrigerant Charge.....	48
Freeze Stat Startup.....	51
Refrigerant Filter Driers .....	57
Suction Filter Removal Instructions.....	58
Low Sound Condenser Fan EC Motor Startup .....	59
OPERATION.....	60
Packaged DX Cooling Operation .....	60
Direct Fire Unit with Return Air Gas Heater Operation.....	60
Direct Fire Unit Gas Heater Operation .....	60
Electric Heating Operation.....	61
Steam or Hot Water Preheating and Heating Operation.....	61
Chilled Water or Non-Compressorized DX Cooling Operation .....	61
MAINTENANCE .....	62
Supply Fans .....	62
DX Cooling.....	62
Condensate Drain Pans .....	62
Filter Replacement .....	62
Air-Cooled Condenser.....	63
E-Coated Coil Cleaning .....	63
Microchannel Coil Cleaning.....	65
<b>OPTIONS .....</b>	<b>66</b>
Chilled Water Coil.....	67
Packaged Direct Expansion (DX) Units.....	68
Note: Multiple Units with Multiple Unit Controllers .....	69
Evaporative Condenser .....	70
Performance.....	71
Temporary Drain-Evaporative Condenser.....	72
Condenser Tube Inspection .....	72
Pre Start-Up .....	72
Cleanliness .....	72
Freeze Protection .....	72
Recirculating Water System.....	72
Pump Operation.....	73
Running.....	73
Condenser Fan Motors.....	73
Water Makeup Valve .....	73
Water Treatment System.....	74
Storage.....	75
Pump Maintenance.....	75
Fan Motor Maintenance .....	75
Access Doors .....	75
Bearings - Lubrication .....	76
Recommended Monthly Inspection.....	76
Mist Eliminators .....	76

<i>Air Inlet</i> .....	77
<i>Stainless Steel Base Pan</i> .....	77
<i>Propeller Fans and Motors</i> .....	77
<i>Recommended Annual Inspection</i> .....	77
<i>Cleaning</i> .....	77
<i>Warranties</i> .....	77
<i>Energy Recovery Units</i> .....	79
<i>Airflow Balancing and Checking</i> .....	79
<i>Controls</i> .....	79
<i>Wheel Set Purge Angle</i> .....	80
<i>Wheel Check Purge Seal</i> .....	81
<i>Wheel Air Seal Adjustments</i> .....	81
<i>Wheel to Air Seal Clearance</i> .....	82
<i>Wheel Installation</i> .....	82
<i>Wheel Accessibility</i> .....	82
<i>Wheel Orientation &amp; Support</i> .....	82
<i>Wheel Startup Procedure</i> .....	83
<i>Wheel Routine Maintenance and Handling</i> .....	83
<i>Wheel Drive Components</i> .....	84
<i>Wheel Air Seals</i> .....	84
<i>Wheel Service</i> .....	84
<i>Wheel Drive Motor and Pulley Replacement</i> .....	86
<i>Wheel Belt Replacement</i> .....	86
<i>Aluminum Wheel Cleaning</i> .....	88
<i>Polymer Wheel Cleaning</i> .....	88
<i>Gas or Electric Heating</i> .....	90
<i>Gas Heating</i> .....	91
<i>Direct Fired Gas Heating</i> .....	99
<i>Phase and Brownout Protection Module</i> .....	104
<i>DPM Setup Procedure</i> .....	104
<i>Average Voltage Screen</i> .....	105
<i>Fault Words:</i> .....	105
<i>UV Lights</i> .....	106
<i>Filter Replacement</i> .....	106
<i>Replacement Parts</i> .....	108
<i>AAON Warranty, Service and Parts Department</i> .....	108
APPENDIX A - HEAT EXCHANGER CORROSION RESISTANCE .....	109
<i>Corrosion Resistance of Copper and Stainless Steel in Brazed Plate Heat Exchangers</i> .....	111
APPENDIX B - THERMISTOR TEMPERATURE VS. RESISTANCE VALUES .....	113
RZ SERIES STARTUP FORM .....	114
MAINTENANCE LOG (E-COATED COIL) .....	121
LITERATURE CHANGE HISTORY .....	122
<i>September 2020</i> .....	122
<i>January 2022</i> .....	122
<i>February 2022</i> .....	122
<i>January 2023</i> .....	122
<b>AAON</b> .....	<b>116</b>

## Index of Tables and Figures

### Tables

Table 1 - Air-Cooled Condenser Unit Clearances 45-240 ton.....	31
Table 2 - Evaporative Condenser Unit Clearances 45-240 ton.....	31
Table 3 - Mounting Dimensions .....	35
Table 4 - Nameplate Voltage Markings & Tolerances .....	40
Table 5 – 35 KAIC Fuse Sizing.....	42
Table 6 – 35 KAIC Fuse Sizing.....	42
Table 7 - Draw-Through Drain Trap Dimensions (Metric) .....	43
Table 8 - Draw-Through Drain Trap Dimensions (Imperial) .....	44
Table 9 - Blow-Through Drain Trap Dimensions (Metric) .....	44
Table 10 - Blow-Through Drain Trap Dimensions (Imperial).....	45
Table 11 - Plenum Fan Set Screw Specifications .....	47
Table 12 - Acceptable Fin & Tube Sub-Cooling and Superheat Temperatures.....	50
Table 13 - Acceptable Microchannel Air-Cooled Condenser Coil Liquid Sub Cooling Values (Metric)..	50
Table 14 - Acceptable Microchannel Air-Cooled Condenser Coil Liquid Sub-Cooling Values (Imperial) .....	51
Table 16 M - R-410A Refrigerant Temperature-Pressure Chart (Metric) .....	54
Table 16 I - R-410A Refrigerant Temperature-Pressure Chart (Imperial).....	55
Table 17 - R-454B Refrigerant Temperature-Pressure Chart (Metric).....	56
Table 18 - R-454B Refrigerant Temperature-Pressure Chart (Imperial).....	57
Table 19- Filter Drier Maximum Pressure Drop.....	57
Table 20 - EC Condenser Fan Cycling Options.....	59
Table 21 - Hot Water Coil Connection Sizes.....	67
Table 22 - Steam Distributing Coil Connection Sizes .....	67
Table 23 - Chilled Water Coil Connection Sizes.....	67
Table 24 - Min and Max Water Pressures and Temps.....	68
Table 25 - Energy Recovery Wheel Cleaning Frequency.....	87
Table 26 - RZ 45-140 ton Electric Heating Capacities .....	90
Table 27- RZ 145-240 ton Electric Heating Capacities.....	90
Table 28 - RZ 45-140 ton Gas Heating Capacities .....	90
Table 29 - RZ 145-240 ton Gas Heating Capacities .....	90
Table 30- Min and Max Gas Pressures (Metric).....	91
Table 31- Min and Max Gas Pressures (Imperial).....	91
Table 32 - RZ 45-140 ton Unit Gas Piping Connections .....	91
Table 33 - RZ 145-240 ton Unit Gas Piping Connections .....	91
Table 34 – <b>(Metric)</b> Natural Gas Maximum Piping Capacities (m <sup>3</sup> /hr) .....	92
Table 35 – <b>(Imperial)</b> Natural Gas Maximum Piping Capacities (ft <sup>3</sup> /hr).....	92
Table 36 – <b>(Metric)</b> Propane (kW) Maximum Piping Capacities .....	92
Table 37 – <b>(Imperial)</b> Propane (kBtu/hr) Maximum Piping Capacities .....	92
Table 38 - Piping Support Intervals (Metric).....	94
Table 39 - Piping Support Intervals (Imperial).....	94
Table 40- Maximum Temperature Rise Setpoint for Return Air Units .....	100
Table 41- Air Disinfection UV Information .....	106
Table 42 - RZ Series Filter Sizes .....	107
Table 43 - Metal Mesh and HEPA Filter Sizes.....	108

## Figures

Figure 1- Lockable Door Handles.....	30
Figure 2 - RZ Series Unit Orientation.....	31
Figure 3 - Base Rail Lifting Lug.....	32
Figure 4 - 4 Point Lift RZ Series Air-Cooled Condenser Unit.....	33
Figure 5 - 8 Point Lift RZ Series Air-Cooled Condenser Unit.....	34
Figure 6 - Curb Mounting.....	35
Figure 7 - Curb Detail.....	35
Figure 8 - Curb & Steel Mounting Rail with Dimensions.....	35
Figure 9 - Unit Base and Sides.....	36
Figure 10 - Unit Roof Flange Splice Detail.....	36
Figure 11 - Staggered assembly for refrigeration pipes.....	37
Figure 12 - Air Hood Shown in the Open Position.....	38
Figure 13 - Factory Supplied End Flashings.....	39
Figure 14 - Vestibule Exhaust Fan.....	39
Figure 15 - Motorized Exhaust.....	39
Figure 16 - Power Block.....	41
Figure 17 - Draw-Through Drain Trap.....	43
Figure 18 - Blow-Through Drain Trap.....	44
Figure 19 - Top Clip and Side Spring Fastener Securing Filters in Place.....	45
Figure 20 - Air Volume Band.....	46
Figure 21 - Air Volume Band Tab Locations.....	47
Figure 22 - Securing Air Volume Band Ends.....	47
Figure 23 - Plenum Fan Gap Tolerances.....	47
Figure 24 - Closed Back Draft Damper.....	48
Figure 25 - Open Back Draft Damper.....	48
Figure 26 - Replaceable Core Liquid Filter/Driers Suction Filter.....	58
Figure 27 - RPE-48-BD filter element.....	58
Figure 28 - Proper Unit Location.....	71
Figure 29 - Improper Unit Locations.....	71
Figure 30 - Temporary Drain Components.....	72
Figure 31 - Water Makeup Valve.....	74
Figure 32 - Evaporative condenser access door.....	76
Figure 33 - Polymer Energy Recovery Wheel.....	80
Figure 34 - Polymer Wheel Segment Removal Pattern.....	85
Figure 35 - Defrost Timer.....	89
Figure 36- Temperature Dial.....	89
Figure 37 - Gas Heater Rain Hood.....	96
Figure 38 - Gas Heater Rain Hood Screws.....	96
Figure 39- Gas Heat Exchanger.....	99
Figure 40- Typical Factory Mutual (FM) Gas Piping Schematic for a Direct Fired Heater.....	100
Figure 41 - Removing Piping Scale with Pin Vise.....	103

# AAON® RZ Series Features and Options Introduction

## Energy Efficiency

- Direct Drive Airfoil Plenum Supply Fans
- Variable Speed R-410A and R-454B Scroll Compressors
- AAON Evaporative Condenser
- Airside Economizer
- Factory Installed AAONAIR® Energy Recovery Wheels
- Double Wall Rigid Polyurethane Foam Panel Construction, R-13 Insulation
- Modulating Gas Heaters
- Modulating/SCR Electric Heaters
- Premium Efficiency Permanent Magnet Motors
- Variable Speed Supply/Return/Exhaust Fans

## Indoor Air Quality

- 100% Outside Air
- Outside Airflow Monitoring
- Economizer CO<sub>2</sub> Override
- High Efficiency Filtration
- Final Filters, including Gas Heat Systems
- UV Lights for Single Pass 90% Air Disinfection
- Double Wall Rigid Polyurethane Foam Panel Construction, R-13 Insulation
- Interior Corrosion Protection

## Humidity Control

- High Capacity Cooling Coils
- Variable Speed Compressors
- Factory Installed AAONAIR® Total Energy Recovery Wheels
- Modulating Hot Gas Reheat

## Safety

- Burglar Bars
- Freeze Stats
- Phase and Brown Out Protection
- Supply/Return Smoke Detectors
- Supply/Return Firestats
- Remote Safety Shutdown Terminals

## Installation and Maintenance

- Clogged Filter Switch
- Color Coded Wiring Diagram
- Compressors in Isolated Compartment
- Compressor Isolation Valves
- Convenience Outlet
- Direct Drive Supply Fans
- VFD Shaft Grounding
- Hinged Access Doors with Lockable Handles
- Magnehelic Gauge
- Service Lights
- Sight Glasses
- BACnet MSTP with Diagnostics
- Remote Start-Stop Terminals
- Access Door Windows
- Motorized Fresh Air Service Vestibule

## System Integration

- Chilled Water Cooling Coils
- Electric/Natural Gas/LP Heating
- Hot Water/Steam Heating Coil
- Non-Compressorized DX Coils

## Environmentally Friendly

- Airside Economizers
- Factory Installed AAONAIR® Energy Recovery Wheels
- R-410A Refrigerant
- R-454B Refrigerant

## Extended Life

- 5 Year Compressor Warranty
- 25 Year Stainless Steel Heat Exchanger Warranty
- Interior Corrosion Protection
- Polymer E-Coated Coils - 5 Year Coating Warranty
- Stainless Steel Coil Casing
- Stainless Steel Drain Pans



## Safety

Attention must be paid to the following statements:

**NOTE** - Notes are intended to clarify the unit installation, operation and maintenance.

**⚠ CAUTION** - Caution statements are given to prevent actions that may result in equipment damage, property damage, or personal injury.

**⚠ WARNING** - Warning statements are given to prevent actions that could result in equipment damage, property damage, personal injury or death.

**⚠ DANGER** - Danger statements are given to prevent actions that will result in equipment damage, property damage, severe personal injury or death.

### **⚠ WARNING**

#### **ELECTRIC SHOCK, FIRE OR EXPLOSION HAZARD**

Failure to follow safety warnings exactly could result in dangerous operation, serious injury, death or property damage.

Improper servicing could result in dangerous operation, serious injury, death, or property damage.

- Before servicing, disconnect all electrical power to the furnace. More than one disconnect may be provided.
- When servicing controls, label all wires prior to disconnecting. Reconnect wires correctly.
- Verify proper operation after servicing. Secure all doors with key-lock or nut and bolt.

### **⚠ CAUTION**

#### **WHAT TO DO IF YOU SMELL GAS**

- Do not try to turn on unit.
- Shut off main gas supply.
- Do not touch any electric switch.
- Do not use any phone in the building.
- Never test for gas leaks with an open flame.
- Use a gas detection soap solution and check all gas connections and shut off valves.

### **⚠ WARNING**

Electric shock hazard. Before servicing, shut off all electrical power to the unit, including remote disconnects, to avoid shock hazard or injury from rotating parts. Follow proper Lockout-Tagout procedures.

**! WARNING**

**FIRE, EXPLOSION OR CARBON MONOXIDE POISONING HAZARD**

Failure to replace proper controls could result in fire, explosion or carbon monoxide poisoning. Failure to follow safety warnings exactly could result in serious injury, death or property damage. Do not store or use gasoline or other flammable vapors and liquids in the vicinity of this appliance.

**! WARNING**

On heaters which recirculate room air, outside ventilation air must be provided in accordance with the information shown on the heater nameplate.

**! WARNING**

**CARBON MONOXIDE POISONING HAZARD**

Failure to follow instructions could result in severe personal injury or death due to carbon-monoxide poisoning, if combustion products infiltrate into the building.

Check that all openings in the outside wall around the vent (and air intake) pipe(s) are sealed to prevent infiltration of combustion products into the building.

Check that furnace vent (and air intake) terminal(s) are not obstructed in any way during all seasons.

**! WARNING**

During installation, testing, servicing, and troubleshooting of the equipment it may be necessary to work with live electrical components. Only a qualified licensed electrician or individual properly trained in handling live electrical components must perform these tasks.

Standard NFPA-70E, an OSHA regulation requiring an Arc Flash Boundary to be field established and marked for identification of where appropriate Personal Protective Equipment (PPE) be worn, must be followed.

**! CAUTION**

Unit power supply wire must be only copper or aluminum.

**! WARNING**

**ROTATING COMPONENTS**

Unit contains fans with moving parts that can cause serious injury. Do not open door containing fans until the power to the unit has been disconnected and fan wheel has stopped rotating.

**! WARNING**

**GROUNDING REQUIRED**

All field installed wiring must be completed by qualified personnel. Field installed wiring must comply with NEC/CEC, local and state electrical code requirements. Failure to follow code requirements could result in serious injury or death. Provide proper unit ground in accordance with these code requirements.

**! WARNING**

**VARIABLE FREQUENCY DRIVES**

Do not leave VFDs unattended in hand mode or manual bypass. Damage to personnel or equipment can occur if left unattended. When in hand mode or manual bypass mode VFDs will not respond to controls or alarms.

**! CAUTION**

Electric motor over-current protection and overload protection may be a function of the Variable Frequency Drive to which the motors are wired. Never defeat the VFD motor overload feature. The overload ampere setting must not exceed 115% of the electric motors FLA rating as shown on the motor nameplate.

**! WARNING**

**UNIT HANDLING**

To prevent injury or death, lifting equipment capacity must exceed unit weight by an adequate safety factor. Always test-lift unit not more than 24 inches high to verify proper center of gravity lift point to avoid unit damage, injury or death.

**! CAUTION**

Failure to properly drain and vent coils when not in use during freezing temperature may result in coil and equipment damage.

**! CAUTION**

Rotation must be checked on all MOTORS AND COMPRESSORS of 3 phase units at startup by a qualified service technician. Scroll compressors are directional and can be damaged if rotated in the wrong direction. Compressor rotation must be checked using suction and discharge gauges. Fan motor rotation must be checked for proper operation. Alterations must only be made at the unit power connection

**! WARNING**

Do not use oxygen, acetylene or air in place of refrigerant and dry nitrogen for leak testing. A violent explosion may result causing injury or death.

**! WARNING**

**WATER PRESSURE**

Prior to connection of condensing water supply, verify water pressure is less than maximum pressure shown on unit nameplate. To prevent injury or death due to instantaneous release of high pressure water, relief valves must be field supplied on system water piping.

**! WARNING**

Always use a pressure regulator, valves and gauges to control incoming pressures when pressure testing a system. Excessive pressure may cause line ruptures, equipment damage or an explosion which may result in injury or death.

**! CAUTION**

To prevent damage to the unit, do not use acidic chemical coil cleaners. Do not use alkaline chemical coil cleaners with a pH value greater than 8.5, after mixing, without first using an aluminum corrosion inhibitor in the cleaning solution.

**! WARNING**

Some chemical coil cleaning compounds are caustic or toxic. Use these substances only in accordance with the manufacturer's usage instructions. Failure to follow instructions may result in equipment damage, injury or death.

**! CAUTION**

Do not clean DX refrigerant coils with hot water or steam. The use of hot water or steam on refrigerant coils will cause high pressure inside the coil tubing and damage to the coil.

**! CAUTION**

Door compartments containing hazardous voltage or rotating parts are equipped with door latches to allow locks. Door latches are shipped with nut and bolts requiring tooled access. If you do not replace the shipping hardware with a pad lock always re-install the nut & bolt after closing the door.

**! CAUTION**

Cleaning the cooling tower or condenser water loop with harsh chemicals such as hydrochloric acid (muriatic acid), chlorine or other chlorides, can damage the refrigerant-to-water heat exchanger. Care must be taken to avoid allowing chemicals to enter the refrigerant-to-water heat exchanger. See Appendix A - Heat Exchanger Corrosion Resistance for more information.

**! CAUTION**

In order to avoid a hazard due to inadvertent resetting of the THERMAL CUT-OUT, this appliance must not be supplied through an external switching device, such as a timer, or connected to a circuit that is regularly switched on and off by the utility.

**! WARNING**

**OPEN LOOP APPLICATIONS**

Failure of the condenser as a result of chemical corrosion is excluded from coverage under AAON Inc. warranties and the heat exchanger manufacturer's warranties.

**! WARNING**

**UV LIGHTS**

Never expose eyes or skin to UVC light from any source, as personal injury may result. Wear gloves, face shield/glasses (per ANSI Z87.1) and cover all exposed skin.

**! WARNING**

**WATER FREEZING**

Failure of the condenser due to freezing will allow water to enter the refrigerant circuit and will cause extensive damage to the refrigerant circuit components. Any damage to the equipment as a result of water freezing in the condenser is excluded from coverage under AAON warranties and the heat exchanger manufacturer warranties.

**! WARNING**

This appliance is not intended for use by persons with reduced physical, sensory or mental capabilities, or lack of experience and knowledge, unless they have been given supervision or instruction concerning use of the appliance by a person responsible for their safety. Children must be supervised around this appliance.

**! WARNING**

**COMPRESSOR CYCLING**

**3 MINUTE MINIMUM OFF TIME**

To prevent motor overheating compressors must cycle off for a minimum of 3 minutes.

**5 MINUTE MINIMUM ON TIME**

To maintain the proper oil level compressors must cycle on for a minimum of 5 minutes.

The cycle rate must not exceed 7 starts per hour.

**! WARNING**

If refrigerant leak is detected, remove/extinguish all sources of open flame. If repairing refrigerant leak requires brazing, remove all refrigerant before beginning brazing.

**! WARNING**

Do not use torch or other potential ignition source to detect refrigerant leaks. Use only electronic detector suitable for the refrigerant, or bubble method with chlorine free detergent.

**! WARNING**

Connected ductwork must be free of potential ignition sources, such as hot surfaces above 700 °C (1292 °F) or electrical devices prone to arcing or sparking. Potential ignition sources within the ductwork may only be allowed if the minimum air velocity across these components is above 1 m/s (200 ft/min) during any point which the component can function.

**! WARNING**

This appliance contains a flammable refrigerant. Minimum floor area on nameplate is based on factory charge at a ceiling/release height of 2.2 m (7.2 ft). Refer to Table 15 for different allowable room areas based on other charges and ceiling/release heights.

**! WARNING**

If this appliance is installed to serve a conditioned area less than the minimum area as indicated in Table 15, the served space must be free of continuously operating open flames or other sources of ignition. Additional ventilation is required in accordance with ASHRAE 15.

**! WARNING**

Only auxiliary devices approved by manufacturer or declared suitable with the refrigerant may be installed in ductwork.

**! WARNING**

Minimum circulation airflow is required to prevent stagnation of refrigerant in the event of a refrigerant leak. Zone dampers and VAV boxes must be operated to allow for minimum circulation airflow in the event of a refrigerant leak



**! WARNING**

Do not operate UV-C lamps outside of the unit.



**! CAUTION**

Disconnect power to the unit before servicing UV-C lamps



**! CAUTION**

Doors and panels with access to UV-C lamps, with possible spectral irradiance exceeding 1.7 μW/cm<sup>2</sup> are provided with an interlock switch. Do not over-ride.



## WARNING

Units containing UV-C Germicidal lamps should not be operated with damage to the cabinet of the unit. UV-C radiation may, even in small doses, cause harm to the eyes and skin.



## WARNING

Units with VFD driven motors/compressors have adjustable overload settings. These are set by the AAON factory for the protection of these motors/compressors and must not be adjusted over this factory setpoint or bypassed.

1. Startup and service must be performed by a Factory Trained Service Technician competent in working with flammable refrigerants.
2. Use only with type of the gas approved for the furnace. Refer to the furnace rating plate.
3. The unit is for outdoor use only. See General Information section for more information.
4. Provide adequate combustion ventilation air to the furnace. If a vent duct extension is used, a class III approved vent is required. See the Locating Units and Gas Heating sections of the Installation section of the manual.
5. Always install and operate furnace within the intended temperature rise range and duct system external static pressure (ESP) as specified on the unit nameplate.
6. The supply and return air ducts must be derived from the same space. It is recommended ducts be provided with access panels to allow inspection for duct tightness. When a down flow duct is used with electric heat, the exhaust duct must be an L shaped duct.
7. Clean furnace, duct, and components upon completion of the construction setup. Verify furnace operating conditions including input rate, temperature rise, and ESP.
8. Every unit has a unique equipment nameplate with electrical, operational, and unit clearance specifications. Always refer to the unit nameplate for specific ratings unique to the model you have purchased.
9. READ THE ENTIRE INSTALLATION, OPERATION, AND MAINTENANCE MANUAL. OTHER IMPORTANT SAFETY PRECAUTIONS ARE PROVIDED THROUGHOUT THIS MANUAL.
10. Keep this manual and all literature safeguarded near or on the unit.

## RZ Series Feature String Nomenclature

GEN	MJREV	SIZE	SERIES	MNREV	VLT	A1	A2	A3	A4	A5	B1	B2	B3	B4	B5	1	2	3A	3B	3C	3D	3E	4A	4B	4C	5A	5B	5C	5D	5E	6A	6B	6C	6D	6E	7	8	9A	9B	9D									
RZ	A	-145	-D	0	3	-C	A	B	0	A	-	0	0	0	0	:	N	0	-	A	A	K	A	Q	-	J	)	)	-	B	F	Γ	)	M	-	0	)	)	)	)	.	Q	F	-	A	0	.	A	
				-	0	0	-	M	0	-	C	-	0	0	0	-	8	0	-	D	A	0	B	-	0	0	-	0	0	0	-	A	B	E	Q	)	A	-	0	)	)	)	.	0	0	)	0	)	B
				10A	10B	11A	11B	12	13A	13B	13C	14	15	16A	16B	16C	16D	17A	17B	18A	18B	18C	19	20	21	22	23	24	25	26	27	28	29	30	31	32	33	34	35	36	37								

### MODEL OPTIONS

#### SERIES AND GENERATION

RZ

#### MAJOR REVISION

A

#### UNIT SIZE

##### Air-Cooled Condenser

45 = 45 ton Capacity  
 55 = 55 ton Capacity  
 65 = 65 ton Capacity  
 75 = 75 ton Capacity  
 90 = 90 ton Capacity  
 105 = 105 ton Capacity  
 120 = 120 ton Capacity  
 130 = 130 ton Capacity  
 140 = 140 ton Capacity  
 145 = 145 ton Capacity  
 160 = 160 ton Capacity  
 180 = 180 ton Capacity  
 200 = 200 ton Capacity  
 220 = 220 ton Capacity  
 240 = 240 ton Capacity

##### Evaporative Condenser

51 = 51 ton Capacity  
 66 = 66 ton Capacity  
 73 = 73 ton Capacity  
 79 = 79 ton Capacity  
 101 = 101 ton Capacity  
 109 = 109 ton Capacity  
 124 = 124 ton Capacity  
 136 = 136 ton Capacity  
 148 = 148 ton Capacity  
 161 = 161 ton Capacity  
 172 = 172 ton Capacity  
 197 = 197 ton Capacity  
 221 = 221 ton Capacity  
 241 = 241 ton Capacity  
 261 = 261 ton Capacity

#### SERIES

##### *Air-Cooled*

A = 45-75 ton units  
 B = 90-105 ton units  
 C = 120-140 ton units  
 D = 145-180 ton units  
 E = 200-240 ton units

##### *Evaporative Condenser*

A = 51-79 ton units  
 B = 101-109 ton units  
 C = 124-148 ton units  
 D = 161-197 ton units  
 E = 221-261 ton units

#### MINOR REVISION

0 = RZ-075 and higher  
 A = only for RZ-045,055,065 changing to 2-circuits

#### VOLTAGE

2 = 230V/3 Φ /60Hz  
 3 = 460V/3 Φ /60Hz  
 4 = 575V/3 Φ /60Hz  
 8 = 208V/3 Φ /60Hz

#### Model Option A: COOLING/HEAT PUMP

##### A1: COMPRESSOR STYLE

0 = No Compressor  
 C = R-410A Variable Speed Scroll Compressor  
 H = R-454B Variable Speed Scroll Compressor  
 N = DX Air Handling Unit

##### A2: CONDENSER STYLE

0 = No Condenser  
 A = Microchannel Air-Cooled Condenser  
 H = Evaporative Condenser

##### A3: INDOOR COIL CONFIGURATION

0 = No Cooling Coil  
 A = Std Row Std Size Evaporator  
 B = 6 Row Std Size Evaporator  
 C = Std Row Large Size Evaporator  
 D = 6 Row Large Size Evaporator  
 E = 4 Row Chilled Water Coil Std Size  
 F = 6 Row Chilled Water Coil Std Size  
 G = 8 Row Chilled Water Coil Std Size  
 H = 4 Row Chilled Water Coil Large Size  
 J = 6 Row Chilled Water Coil Large Size  
 K = 8 Row Chilled Water Coil Large Size

##### A4: COOLING HEAT EXCHANGER CONSTRUCTION

0 = Standard  
 A = Polymer E-Coated Cooling Coil  
 B = Stainless Steel Cooling Coil Casing  
 D = Stainless Steel Cooling Coil Casing + Polymer E-Coated Cooling Coil  
 E = Polymer E-Coated Cond. Coil  
 J = Polymer E-Coated Evap. And Cond. Coil  
 T = Stainless Steel Cooling Coil Casing + Polymer E-Coated Evap. And Cond. Coil



## RZ Series Feature String Nomenclature

GEN	MREV	SIZE	SERIES	MNREV	VLT	A1	A2	A3	A4	A5	B1	B2	B3	B4	B5	1	2	3A	3B	3C	3D	3E	4A	4B	4C	5A	5B	5C	5D	5E	6A	6B	6C	6D	6E	7	8	9A	9B	9C	9D	
RZ	A	- 145	- D	0	- 3	- C	A	B	0	A	- 0	0	0	0	0	:	N	0	- A	A	K	A	Q	- J	0	0	- B	F	T	0	M	- 0	0	0	0	0	- C	F	- A	0	A	A
				- 0	0	- M	0	- C	- 0	0	0	- 8	0	- D	A	0	B	- 0	0	- 0	0	0	- A	B	E	Q	0	A	- E	0	0	0	0	0	- C	0	0	0	0	I	B	
				10A	10B	11A	11B	12	13A	13B	13C	14	15	16A	16B	16C	16D	17A	17B	18A	18B	18C	19	20	21	22	23	24	25	26	27	28	29	30	31	32	33	34	35	36	37	

### **A5: COOLING STAGING**

0 = No Cooling  
 A = Full Face Variable Capacity + Tandem On/Off Refrigeration Systems  
 E = All Variable Capacity Refrigeration Systems  
 F = Single Serpentine 8 FPI  
 G = Half Serpentine 8 FPI  
 H = Single Serpentine 10 FPI J = Half Serpentine 10 FPI  
 K = Single Serpentine 12 FPI L = Half Serpentine 12 FPI  
 M = DX Air Handling Unit with 4 Refrigeration Circuits  
 N = DX Air Handling Unit with 8 Refrigeration Circuits

### **Model Option B: HEATING**

#### **B1: HEAT TYPE**

0 = No Heat  
 B = Electric Heat  
 D = Natural Gas Single Rack  
 E = Natural Gas Double Rack  
 K = Hot Water Coil  
 M = Steam Distributing Coil

#### **B2: HEAT CONSTRUCTION**

0 = Standard  
 B = Stainless Steel Heat Exchanger  
 D = High Altitude Stainless Steel Heat Exchanger  
 G = Polymer E-Coated Heating Coil

#### **B3: HEAT DESIGNATION**

0 = No Heat  
 1 = Heat 1  
 2 = Heat 2  
 3 = Heat 3  
 4 = Heat 4  
 5 = Heat 5  
 6 = Heat 6  
 7 = Heat 7  
 8 = Heat 8

### **B3: HEAT DESIGNATION Continued**

A = 1 Row Size A  
 B = 1 Row Size B  
 C = 1 Row Size C  
 D = 1 Row Size D  
 E = 2 Row Size A  
 F = 2 Row Size B  
 G = 2 Row Size C  
 H = 2 Row Size D

### **B4: HEAT STAGING**

0 = No Heat  
 A = 1 Stage  
 B = 2 Stage  
 C = 3 Stage  
 D = 4 Stage  
 E = 5 Stage  
 F = 6 Stage  
 G = 7 Stage  
 H = 8 Stage  
 V = 10 Stage  
 J = 12 Stage  
 K = Modulating Gas Heat Temp Control  
 L = High Turndown Modulating Gas Heat – Temperature Control  
 M = Modulating SCR with Temperature Control  
 N = Modulating SCR with External 0-10 VDC  
 R = Single Serpentine 10 FPI  
 S = Half Serpentine 10 FPI

### **B5: HEAT PUMP AUX HEATING**

0 = No Heat Pump

## RZ Series Feature String Nomenclature

GEN	MREV	SIZE	SERIES	MNREV	VLT	A1	A2	A3	A4	A5	B1	B2	B3	B4	B5	1	2	3A	3B	3C	3D	3E	4A	4B	4C	5A	5B	5C	5D	5E	6A	6B	6C	6D	6E	7	8	9A	9B	9C	9D		
RZ	A	- 145	- D	0	- 3	- C	A	B	0	A	- 0	0	0	0	0	0	0	N	0	- A	A	K	A	Q	- J	0	0	- B	F	T	0	M	- 0	0	0	0	0	0	- C	F	- A	0	A
				- 0	0	- M	0	- C	- 0	0	0	- 8	0	- D	A	0	B	- 0	0	- 0	0	0	- A	B	E	Q	0	A	- E	0	0	0	0	0	- C	0	0	0	0	I	B		
				10A	10B	11A	11B	12	13A	13B	13C	14	15	16A	16B	16C	16D	17A	17B	18A	18B	18C	19	20	21	22	23	24	25	26	27	28	29	30	31	32	33	34	35	36	37		

### 1: UNIT ORIENTATION

- E = Draw Through SA Fan, Walk-in Vestibule, Left Side Access
- F = Draw Through SA Fan, Walk-in Vestibule, Right Side Access
- G = Draw Through SA Fan, Non-compressorized, End Control Panel, Left Access
- H = Draw Through SA Fan, Non-compressorized, End Control Panel, Right Access
- J = Draw Thru Supply Fan, Non-compressorized, Left Control Panel, Left Access
- K = Draw Thru Supply Fan, Non-compressorized, Right Control Panel, Right Access
- L = Draw Through SA Fan, Non-compressorized, Walk-in Vestibule, Left Access
- M = Draw Through SA Fan, Non-compressorized, Walk-in Vestibule, Right Access
- N = Blow Through SA Fan, Walk-in Vestibule, Left Side Access
- P = Blow Through SA Fan, Walk-in Vestibule, Right Side Access
- Q = Blow Through SA Fan, Non-compressorized, End Control Panel, Left Access
- R = Blow Through SA Fan, Non-compressorized, End Control Panel, Right Access
- S = Blow Thru Supply Fan, Non-compressorized, Left Control Panel, Left Access
- T = Blow Thru Supply Fan, Non-compressorized, Right Control Panel, Right Access
- U = Blow Through SA Fan, Non-compressorized, Walk-in Vestibule, Left Access
- V = Blow Through SA, Fan Non-compressorized, Walk-in Vestibule, Right Access
- W = Draw Thru Supply Fan, End Control Panel, Left Side Air Tunnel Access
- Y = Draw Thru Supply Fan, End Control Panel, Right Side Air Tunnel Access
- Z = Blow Thru Supply Fan, End Control Panel, Left Side Air Tunnel Access
- 1 = Blow Thru Supply Fan, End Control Panel, Right Side Air Tunnel Access

### 2: SUPPLY & RETURN LOCATIONS

- 0 = Bottom Supply--Bottom Return
- A = Bottom Supply--No Return
- B = Bottom Supply--Left Return
- C = Bottom Supply--Right Return
- D = Bottom Supply--End Return
- E = Left Supply--No Return
- F = Left Supply--Bottom Return
- G = Left Supply--Left Return
- H = Left Supply--Right Return
- J = Left Supply--End Return
- K = Right Supply--No Return
- L = Right Supply--Bottom Return
- M = Right Supply--Left Return
- N = Right Supply--Right Return
- P = Right Supply--End Return
- Q = Top Supply--No Return
- R = Top Supply--Bottom Return
- S = Top Supply--Left Return
- T = Top Supply--Right Return
- U = Top Supply--End Return
- V = End Supply + No Return
- W = End Supply + Bottom Return
- Y = End Supply + Left Return
- Z = End Supply + Right Return
- 1 = End Supply + End Return

### Feature 3: SUPPLY FAN OPTIONS

#### 3A: SUPPLY FAN QUANTITY

- 0 = 1 Fan
- A = 2 Fans
- B = 3 Fans
- C = 4 Fans
- D = 5 Fans
- E = 6 Fans
- F = 7 Fans
- G = 8 Fans
- H = 9 Fans
- J = 10 Fans
- K = 11 Fans
- L = 12 Fans

## RZ Series Feature String Nomenclature

GEN	MREV	SIZE	SERIES	MNREV	VLT	A1	A2	A3	A4	A5	B1	B2	B3	B4	B5	1	2	3A	3B	3C	3D	3E	4A	4B	4C	5A	5B	5C	5D	5E	6A	6B	6C	6D	6E	7	8	9A	9B	9C	9D		
RZ	A	- 145	- D	0	- 3	- C	A	B	0	A	- 0	0	0	0	0	:	N	0	- A	A	K	A	Q	- J	0	0	- B	F	T	O	M	- 0	0	0	0	0	0	- C	F	- A	0	A	A
				- 0	0	- M	0	- C	- 0	0	0	- 8	0	- D	A	0	B	- 0	0	- 0	0	0	0	- A	B	E	Q	0	A	- E	0	0	0	0	0	0	- (	0	0	(	0	I	B
				10A	10B	11A	11B	12	13A	13B	13C	14	15	16A	16B	16C	16D	17A	17B	18A	18B	18C	19	20	21	22	23	24	25	26	27	28	29	30	31	32	33	34	35	36	37		

### 3B: SUPPLY FAN CONFIGURATION

0 = No VFDs + Full Width Fan  
A = 1 Fan per VFD + Full Width Fan  
B = 2 Fans per VFD + Full Width Fan  
C = 3 Fans per VFD + Full Width Fan  
D = 4 Fans per VFD + Full Width Fan  
E = No VFDs + Narrow Width Fan  
F = 1 Fan per VFD + Narrow Width Fan  
G = 2 Fans per VFD + Narrow Width Fan  
H = 3 Fans per VFD + Narrow Width Fan  
J = 4 Fans per VFD + Narrow Width Fan  
K = Option 0 + Inlet Backdraft Dampers  
L = Option A + Inlet Backdraft Dampers  
M = Option B + Inlet Backdraft Dampers  
N = Option C + Inlet Backdraft Dampers  
P = Option D + Inlet Backdraft Dampers  
Q = Option E + Inlet Backdraft Dampers  
R = Option F + Inlet Backdraft Dampers  
S = Option G + Inlet Backdraft Dampers  
T = Option H + Inlet Backdraft Dampers  
U = Option J + Inlet Backdraft Dampers

### 3C: SUPPLY FAN SIZE

G = 27" Direct Drive Backward Curved Plenum Aluminum  
J = 30" Direct Drive Backward Curved Plenum Steel  
K = 33" Direct Drive Backward Curved Plenum Steel  
L = 36.5" Direct Drive Backward Curved Plenum Aluminum  
M = 42.5" Direct Drive Backward Curved Plenum Aluminum  
N = 18.5" Direct Drive Airfoil Plenum Aluminum  
P = 22" Direct Drive Airfoil Plenum Aluminum  
Q = 24" Direct Drive Airfoil Plenum Aluminum  
R = 27" Direct Drive Airfoil Plenum Aluminum

### 3D: SUPPLY FAN MOTOR TYPE

0 = High Efficiency Open Motor (1170 nominal rpm)  
A = High Efficiency Open Motor (1760 nominal rpm)  
K = High Efficiency Totally Enclosed Motor (1170 nominal rpm)

### 3D: SUPPLY FAN MOTOR TYPE (continued)

L = High Efficiency Totally Enclosed Motor (1760 nominal rpm)  
P = Permanent Magnet AC Totally Enclosed Motor (1760 nominal rpm)

### 3E: SUPPLY FAN MOTOR SIZE

G = 3 hp  
H = 5 hp  
J = 7.5 hp  
K = 10 hp  
L = 15 hp  
M = 20 hp  
N = 25 hp  
P = 30 hp  
Q = 40 hp  
R = 50 hp

### Feature 4: RETURN/OUTSIDE AIR

#### OPTIONS

#### 4A: OUTSIDE AIR SECTION

0 = 100% Outside Air  
A = 100% Outside Air with Motorized Dampers  
B = Manual Outside Air + Return Air Opening  
C = Motorized Outside Air Dampers + Return Air Opening  
D = 100% Return Air  
E = Economizer  
G = Econ + Power Exhaust (Plenum Fans)  
J = Econ + Power Return (Plenum Fans)  
Q = Econ + Energy Recovery + Bypass Damper  
R = Econ + Energy Recovery + Bypass Damper + Power Return (Plenum Fans)

#### 4B: ENERGY RECOVERY TYPE

0 = No Energy Recovery  
A = Polymer Energy Recovery Wheel  
B = Polymer Energy Recovery Wheel + 1% Purge  
C = Aluminum Energy Recovery Wheel  
D = Aluminum Energy Recovery Wheel + 1% Purge

## RZ Series Feature String Nomenclature

GEN	MREV	SIZE	SERIES	MNREV	VLT	A1	A2	A3	A4	A5	B1	B2	B3	B4	B5	1	2	3A	3B	3C	3D	3E	4A	4B	4C	5A	5B	5C	5D	5E	6A	6B	6C	6D	6E	7	8	9A	9B	9C	9D	
RZ	A	- 145	- D	0	- 3	- C	A	B	0	A	- 0	0	0	0	0	:	N	0	- A	A	K	A	Q	- J	0	0	- E	F	T	0	M	- 0	0	0	0	0	- C	F	- A	0	A	A
				- 0	0	- M	0	- C	- 0	0	0	- 8	0	- D	A	0	B	- 0	0	- 0	0	0	- A	B	E	Q	C	A	- E	0	0	0	0	0	- C	0	0	C	0	L	B	
				10A	10B	11A	11B	12	13A	13B	13C	14	15	16A	16B	16C	16D	17A	17B	18A	18B	18C	19	20	21	22	23	24	25	26	27	28	29	30	31	32	33	34	35	36	37	

### **4C: ENERGY RECOVERY SIZE**

- 0 = No Energy Recovery
- A = Small Enthalpy
- B = Medium Enthalpy
- C = Large Enthalpy
- D = Extra Large Enthalpy
- E = Small Sensible
- F = Medium Sensible
- G = Large Sensible
- H = Extra Large Sensible
- J = Small Enthalpy + Exhaust Filters
- K = Medium Enthalpy + Exhaust Filters
- L = Large Enthalpy + Exhaust Filters
- M = Extra Large Enthalpy + Exhaust Filters
- N = Small Sensible + Exhaust Filters
- P = Medium Sensible + Exhaust Filters
- Q = Large Sensible + Exhaust Filters
- R = Extra Large Sensible + Exhaust Filters

### **Feature 5: RETURN FAN OPTIONS**

#### **5A: RETURN FAN QUANTITY**

- 0 = No Return Fan
- A = 1 Fan
- B = 2 Fans
- C = 3 Fans
- D = 4 Fans

#### **5B: RETURN FAN CONFIGURATION**

- 0 = No Return Fan
- A = No VFDs + Full Width Fan
- B = 1 Fan per VFD + Full Width Fan
- C = 2 Fans per VFD + Full Width Fan
- D = 3 Fans per VFD + Full Width Fan
- E = 4 Fans per VFD + Full Width Fan
- F = No VFDs + Narrow Width Fan
- G = 1 Fan per VFD + Narrow Width Fan
- H = 2 Fans per VFD + Narrow Width Fan
- J = 3 Fans per VFD + Narrow Width Fan
- K = 4 Fans per VFD + Narrow Width Fan
- L = Option A + Inlet Backdraft Dampers
- M = Option B + Inlet Backdraft Dampers

### **5B: RETURN FAN CONFIGURATION**

#### **Cont.**

- N = Option C + Inlet Backdraft Dampers
- P = Option D + Inlet Backdraft Dampers
- Q = Option E + Inlet Backdraft Dampers
- R = Option F + Inlet Backdraft Dampers
- S = Option G + Inlet Backdraft Dampers
- T = Option H + Inlet Backdraft Dampers
- U = Option J + Inlet Backdraft Dampers
- V = Option K + Inlet Backdraft Dampers

### **5C: RETURN FAN SIZE**

- 0 = No Return Fan
- N = 27" Direct Drive Backward Curved Plenum Aluminum
- Q = 30" Direct Drive Backward Curved Plenum Steel
- R = 33" Direct Drive Backward Curved Plenum Steel
- S = 36.5" Direct Drive Backward Curved Plenum Aluminum
- T = 42.5" Direct Drive Backward Curved Plenum Aluminum
- U = 18.5" Direct Drive Backwards Airfoil Aluminum
- V = 22" Direct Drive Backwards Airfoil Aluminum
- W = 24" Direct Drive Backwards Airfoil Aluminum
- Y = 27" Direct Drive Backwards Airfoil Aluminum

### **5D: RETURN FAN MOTOR TYPE**

- 0 = No Return Fan
- A = High Efficiency Open Motor (1170 nominal rpm)
- B = High Efficiency Open Motor (1760 nominal rpm)
- L = High Efficiency Totally Enclosed Motor (1170 nominal rpm)
- M = High Efficiency Totally Enclosed Motor (1760 nominal rpm)
- P = Permanent Magnet AC Totally Enclosed Motor (1170 nominal rpm)
- Q = Permanent Magnet AC Totally Enclosed Motor (1760 nominal rpm)

## RZ Series Feature String Nomenclature

GEN	MREV	SIZE	SERIES	MNREV	VLT	A1	A2	A3	A4	A5	B1	B2	B3	B4	B5	1	2	3A	3B	3C	3D	3E	4A	4B	4C	5A	5B	5C	5D	5E	6A	6B	6C	6D	6E	7	8	9A	9B	9C	9D												
RZ	A	-	145	-	D	0	-	3	-	C	A	B	0	A	-	0	0	0	0	0	0	:	N	0	-	A	A	K	A	Q	-	J	0	0	-	B	F	T	0	M	-	0	0	0	0	0	-	C	F	-	0	0	A

**5E: RETURN MOTOR SIZE**

- 0 = No Return Fan
- H = 3 hp
- J = 5 hp
- K = 7.5 hp
- L = 10 hp
- M = 15 hp
- N = 20 hp
- P = 25 hp
- Q = 30 hp
- R = 40 hp

**Feature 6: EXHAUST FAN OPTIONS**

**6A: EXHAUST FAN QUANTITY**

- 0 = No Exhaust Fan
- A = 1 Fan
- B = 2 Fans

**6B: EXHAUST FAN CONFIGURATION**

- 0 = No Exhaust Fan
- A = No VFDs + Full Width Fan
- B = 1 Fan per VFD + Full Width Fan
- C = 2 Fans per VFD + Full Width Fan
- D = 3 Fans per VFD + Full Width Fan
- E = 4 Fans per VFD + Full Width Fan
- F = No VFDs + Narrow Width Fan
- G = 1 Fan per VFD + Narrow Width Fan
- H = 2 Fans per VFD + Narrow Width Fan
- J = 3 Fans per VFD + Narrow Width Fan
- K = 4 Fans per VFD + Narrow Width Fan
- L = Option A + Inlet Backdraft Dampers
- M = Option B + Inlet Backdraft Dampers
- N = Option C + Inlet Backdraft Dampers
- P = Option D + Inlet Backdraft Dampers
- Q = Option E + Inlet Backdraft Dampers
- R = Option F + Inlet Backdraft Dampers
- S = Option G + Inlet Backdraft Dampers
- T = Option H + Inlet Backdraft Dampers
- U = Option J + Inlet Backdraft Dampers
- V = Option K + Inlet Backdraft Dampers

**6C: EXHAUST FAN SIZE**

- 0 = No Exhaust Fan
- N = 27" Direct Drive Backward Curved Plenum Aluminum
- Q = 30" Direct Drive Backward Curved Plenum Steel
- R = 33" Direct Drive Backward Curved Plenum Steel
- S = 36.5" Direct Drive Backward Curved Plenum Aluminum
- T = 42.5" Direct Drive Backward Curved Plenum Aluminum
- U = 18.5" Direct Drive Backwards Airfoil Aluminum
- V = 22" Direct Drive Backwards Airfoil Aluminum
- W = 24" Direct Drive Backwards Airfoil Aluminum
- Y = 27" Direct Drive Backwards Airfoil Aluminum

**6D: EXHAUST FAN MOTOR TYPE**

- 0 = No Exhaust Fan
- A = High Efficiency Open Motor (1170 nominal rpm)
- B = High Efficiency Open Motor (1760 nominal rpm)
- L = High Efficiency Totally Enclosed Motor (1170 nominal rpm)
- M = High Efficiency Totally Enclosed Motor (1760 nominal rpm)
- P = Permanent Magnet AC Totally Enclosed Motor (1170 nominal rpm)
- Q = Permanent Magnet AC Totally Enclosed Motor (1760 nominal rpm)

**6E: EXHAUST MOTOR SIZE**

- 0 = No Exhaust Fan
- H = 3 hp
- J = 5 hp
- K = 7.5 hp
- L = 10 hp
- M = 15 hp
- N = 20 hp
- P = 25 hp
- Q = 30 hp
- R = 40 hp

### RZ Series Feature String Nomenclature

GEN	MREV	SIZE	SERIES	MNREV	VLT	A1	A2	A3	A4	A5	B1	B2	B3	B4	B5	1	2	3A	3B	3C	3D	3E	4A	4B	4C	5A	5B	5C	5D	5E	6A	6B	6C	6D	6E	7	8	9A	9B	9C	9D		
RZ	A	-145	-D	0	-3	-C	A	B	0	A	-0	0	0	0	0	:	N	0	-A	A	K	A	Q	-J	0	0	-B	F	T	O	M	-0	0	0	0	0	0	-C	F	-A	0	A	A
		-00	-M	0	-C	-0	0	0	0	-8	0	-D	A	0	B	-0	0	-0	0	0	0	-A	B	E	Q	0	A	-E	0	0	0	0	0	0	-0	0	0	C	0	I	B		
				10A	10B	11A	11B	12	13A	13B	13C	14	15	16A	16B	16C	16D	17A	17B	18A	18B	18C	19	20	21	22	23	24	25	26	27	28	29	30	31	32	33	34	35	36	37		

**7: O/A CONTROL**

- 0 = Standard (No Actuator)
- C = Fully Modulating Actuator - Sensible Limit
- D = Fully Modulating Actuator - Enthalpy Limit
- E = DDC Actuator
- P = Option C + CO2 Override
- Q = Option D + CO2 Override
- R = Option E + CO2 Override
- U = 2 Position Actuator
- V = Fault Detection and Diagnostics Controller (FDD) Sensible Limit
- W = FDD Enthalpy Limit
- Y = Option V + CO2 Override
- Z = Option W + CO2 Override

**8: RETURN & EXHAUST OPTIONS**

- 0 = No Return Opening
- A = Standard Return Opening without EA Dampers
- B = Large Return Opening without EA Dampers
- E = Standard Return Opening + Motorized EA Dampers
- F = Large Return Opening + Motorized EA Dampers

**Feature 9: FILTER OPTIONS**

**9A: UNIT FILTER TYPE**

- 0 = 2" Pleated MERV 8
- A = 4" Pleated MERV 8
- B = 2" Pleated MERV 8 + 4" Pleated MERV 11
- C = 2" Pleated MERV 8 + 4" Pleated MERV 13
- D = 2" Pleated MERV 8 + 4" Pleated MERV 14
- E = 4" Pleated MERV 8 + 4" Pleated MERV 11
- F = 4" Pleated MERV 8 + 4" Pleated MERV 13
- G = 4" Pleated MERV 8 + 4" Pleated MERV 14
- H = 2" Pleated MERV 8 + 12" Cartridge MERV 11
- J = 2" Pleated MERV 8 + 12" Cartridge MERV 13
- K = 2" Pleated MERV 8 + 12" Cartridge MERV 14
- L = 4" Pleated MERV 8 + 12" Cartridge MERV 11
- M = 4" Pleated MERV 8 + 12" Cartridge MERV 13
- N = 4" Pleated MERV 8 + 12" Cartridge MERV 14
- P = 2" Pleated MERV 8 + 30" Bag MERV 13
- Q = 2" Pleated MERV 8 + 30" Bag MERV 14

**9A: UNIT FILTER TYPE Continued**

- R = 4" Pleated MERV 8 + 30" Bag MERV 13
- S = 4" Pleated MERV 8 + 30" Bag MERV 14
- W = 4" MERV 8 + 12" 99.97 HEPA

**9B: UNIT FILTER BOX SIZE/LOCATION**

- 0 = Standard Filters in Standard Position
- A = Standard Filters in Pre-position
- B = High Eff Filters Box A in Standard Position
- C = High Eff Filters Box B in Standard Position
- D = High Eff Filters Box C in Standard Position
- E = High Eff Filters Box A in Pre-Position
- F = High Eff Filters Box B in Pre-Position
- G = High Eff Filters Box C in Pre-Position
- H = Dual Angled Filter Racks Box A in Standard Position
- J = Dual Angled Filter Racks Box B in Standard Position
- K = Dual Angled Filter Racks Box A in Pre-Position
- L = Dual Angled Filter Racks Box B in Pre-Position
- N = HEPA Filters Box A in Standard Position
- P = HEPA Filters Box B in Standard Position
- Q = HEPA Filters Box A in Pre-position
- R = HEPA Filters Box B in Pre-position

**9C: FINAL FILTER TYPE**

- 0 = No Final Filters
- A = 12" Cartridge MERV 13--Filter Box A
- B = 12" Cartridge MERV 13--Filter Box B
- C = 12" Cartridge MERV 13--Filter Box C
- D = 12" Cartridge MERV 14--Filter Box A
- E = 12" Cartridge MERV 14--Filter Box B
- F = 12" Cartridge MERV 14--Filter Box C
- G = 30" Bag MERV 13--Filter Box A
- H = 30" Bag MERV 13--Filter Box B
- J = 30" Bag MERV 13--Filter Box C
- K = 30" Bag MERV 14--Filter Box A
- L = 30" Bag MERV 14--Filter Box B
- M = 30" Bag MERV 14--Filter Box C
- N = HEPA Frame (No Filter)--Filter Box A

## RZ Series Feature String Nomenclature

GEN	MREV	SIZE	SERIES	MNREV	VLT	A1	A2	A3	A4	A5	B1	B2	B3	B4	B5	1	2	3A	3B	3C	3D	3E	4A	4B	4C	5A	5B	5C	5D	5E	6A	6B	6C	6D	6E	7	8	9A	9B	9C	9D	
RZ	A	-145	-D	0	-3	-C	A	B	0	A	-0	0	0	0	0	:	N	0	-A	A	K	A	Q	-J	0	0	-B	F	T	0	M	-0	0	0	0	0	-Q	F	-A	0	A	A
				-0	0	-M	0	-C	-0	0	0	-8	0	-D	A	0	B	-0	0	-0	0	0	-A	B	E	Q	0	A	-E	0	0	0	0	0	-0	0	0	0	0	0	E	B
				<b>10A</b>	<b>10B</b>	<b>11A</b>	<b>11B</b>	<b>12</b>	13A	13B	13C	14	15	16A	16B	16C	16D	17A	17B	18A	18B	18C	19	20	21	22	23	24	25	26	27	28	29	30	31	32	33	34	35	36	37	

### 9C: FINAL FILTER TYPE (continued)

P = HEPA Frame (No Filter)--Filter Box B  
 Q = 12" 99.97 HEPA--Filter Box A  
 R = 12" 99.97 HEPA--Filter Box B  
 S = 4" MERV 8 + 12" 99.97 HEPA--Filter Box A  
 T = 4" MERV 8 + 12" 99.97 HEPA--Filter Box B

### 9D: FILTER OPTIONS

0 = None  
 A = Clogged Filter Switch - Unit Filters  
 B = Clogged Filter Switch - Unit + Energy Recovery Filters  
 C = Clogged Filter Switch - Unit + Final Filters  
 D = Clogged Filter Switch - Unit + Energy Recovery + Final Filters  
 E = Magnehelic Gauge - Unit Filters  
 F = Magnehelic Gauge - Unit + Energy Recovery Filters  
 G = Magnehelic Gauge - Unit + Final Filters  
 H = Magnehelic Gauge - Unit + Energy Recovery + Final Filters  
 J = CFS + Magnehelic Gauge - Unit Filters  
 K = CFS + Magnehelic Gauge - Unit + Energy Recovery Filters  
 L = CFS + Magnehelic Gauge - Unit + Final Filters  
 M = CFS + Magnehelic Gauge - Unit + Energy Recovery + Final Filters

### Feature 10: REFRIGERATION CONTROL

#### 10A: REFRIGERATION CONTROL A

0 = Standard  
 E = Freeze Stats (each circuit)

#### 10B: REFRIGERATION CONTROL B

0 = Standard

### Feature 11: REFRIGERATION OPTIONS

#### 11A: REFRIGERATION OPTIONS A

0 = Standard  
 D = Hot Gas Bypass Non-Variable Compressor Circuits (HGBNV)  
 E = Modulating Hot Gas Reheat [MHGR]  
 M = HGBNV + MHGR  
 Q = Polymer E-Coated MHGR  
 W = HGBNV + Polymer E-Coated MHGR

#### 11B: REFRIGERATION OPTIONS B

0 = Standard

### 12: REFRIGERATION ACCESSORIES

0 = Standard  
 B = Compressor Isolation Valves  
 C = Sight Glass + Compressor Isolation Valves  
 F = Option B + Variable Circuits -20°F Low Ambient [Size 075 & Series B, C, D, E]  
 F = Option B + Lead Circuit -20°F Low Ambient [Size 045, 055, & 065]  
 G = Option C + Variable Circuits -20°F Low Ambient [Size 075 & Series B, C, D, E]  
 G = Option C + Lead Circuit -20°F Low Ambient [Size 045, 055, & 065]  
 K = Option B + Tandem Circuits -20°F Low Ambient [Size 075 & Series B, C, D, E]  
 K = Option B + Lag Circuit -20°F Low Ambient [Size 045, 055, & 065]  
 L = Option C + Tandem Circuits -20°F Low Ambient [Size 075 & Series B, C, D, E]  
 L = Option C + Lag Circuit -20°F Low Ambient [Size 045, 055, & 065]  
 P = Option B + All Circuits -20°F Low Ambient  
 Q = Option C + All Circuits -20°F Low Ambient

## RZ Series Feature String Nomenclature

GEN	MREV	SIZE	SERIES	MNREV	VLT	A1	A2	A3	A4	A5	B1	B2	B3	B4	B5	1	2	3A	3B	3C	3D	3E	4A	4B	4C	5A	5B	5C	5D	5E	6A	6B	6C	6D	6E	7	8	9A	9B	9C	9D	
RZ	A	- 145	- D	0	- 3	- C	A	B	0	A	- 0	0	0	0	0	:	N	0	- A	A	K	A	Q	- J	0	0	- B	F	T	0	M	- 0	0	0	0	0	0	- C	F	- A	0	A
					- 0	0	- M	0	- C	- 0	0	0	- 8	0	- D	A	0	B	- 0	0	- 0	0	0	- A	B	E	Q	0	A	- E	0	0	0	0	0	- (	0	0	(	0	I	B
				10A	10B	11A	11B	12	<b>13A</b>	<b>13B</b>	<b>13C</b>	14	15	16A	16B	16C	16D	17A	17B	18A	18B	18C	19	20	21	22	23	24	25	26	27	28	29	30	31	32	33	34	35	36	37	

### **Feature 13: POWER OPTIONS**

#### **13A: UNIT DISCONNECT TYPE**

- 0 = Single Point Power - Standard Power Block
- A = Single Point Power - Non-fused Disconnect Power Switch
- B = Single Point Power – Circuit Breaker
- C = Dual Point Power – Standard Power Block – Method #1
- D = Dual Point Power – Non-Fused Disconnect Power Switch – Method #1
- E = Dual Point Power – Circuit Breaker – Method #1
- F = Dual Point Power – Standard Power Block – Method #2
- G = Dual Point Power – Non-Fused Disconnect Power Switch – Method #2
- H = Dual Point Power – Circuit Breaker – Method #2
- J = Dual Point Power – Standard Power Block – Method #3
- K = Dual Point Power – Non-Fused Disconnect Power Switch – Method #3
- L = Dual Point Power – Circuit Breaker – Method #3
- M = Dual Point Power – Standard Power Block– Method #4
- N = Dual Point Power – Non-Fused Disconnect Power Switch – Method #1
- P = Dual Point Power – Circuit Breaker – Method #1

### **13B: DISCONNECT 1 SIZE / 13C: DISCONNECT**

#### **2 SIZE**

- 0 = Power Block
- A = 15 amps
- B = 20 amps
- C = 25 amps
- D = 30 amps
- E = 35 amps
- F = 40 amps
- G = 45 amps
- H = 50 amps
- J = 60 amps
- K = 70 amps
- L = 80 amps
- M = 90 amps
- N = 100 amps
- P = 110 amps
- Q = 125 amps
- R = 150 amps
- S = 175 amps
- T = 200 amps
- U = 225 amps
- V = 250 amps
- W = 300 amps
- Y = 350 amps
- Z = 400 amps
- 1 = 450 amps
- 2 = 500 amps
- 3 = 600 amps
- 4 = 700 amps
- 5 = 800 amps
- 6 = 1000 amps
- 7 = 1200 amps



## RZ Series Feature String Nomenclature

GEN	MJREV	SIZE	SERIES	MNREV	VLT	A1	A2	A3	A4	A5	B1	B2	B3	B4	B5	1	2	3A	3B	3C	3D	3E	4A	4B	4C	5A	5B	5C	5D	5E	6A	6B	6C	6D	6E	7	8	9A	9B	9C	9D
RZ	A	- 145	- D	0	3	- C	A	B	0	A	- 0	0	0	0	0	:	N	0	- A	A	K	A	Q	- J	0	0	- B	F	T	O	M	- 0	0	0	0	0	- C	F	- A	0	A
				- 0	0	- M	0	- C	- 0	0	0	- 8	0	- D	A	0	B	- 0	0	- 0	0	0	- A	B	E	Q	0	A	- E	0	0	0	0	0	- C	0	0	0	0	I	B
				10A	10B	11A	11B	12	13A	13B	13C	14	15	16A	16B	16C	16D	17A	17B	18A	18B	18C	19	20	21	22	23	24	25	26	27	28	29	30	31	32	33	34	35	36	37

### **14: SAFETY OPTIONS**

- 0 = Standard
- A = RA & SA Firestat
- B = RA Smoke Detector
- C = SA Smoke Detector
- D = High Supply Air Static Pressure Switch
- E = Remote Safety Shutdown Terminals
- F = Option A + B
- G = Option A + C
- H = Option A + D
- J = Option A + E
- K = Option B + C
- L = Option B + D
- M = Option B + E
- N = Option C + D
- P = Option C + E
- Q = Option D + E
- R = Option A + B + C
- S = Option A + B + D
- T = Option A + B + E
- U = Option A + C + D
- V = Option A + C + E
- W = Option A + D + E
- Y = Option B + C + D
- Z = Option B + C + E
- 1 = Option B + D + E
- 2 = Option C + D + E
- 3 = Option A + B + C + D
- 4 = Option A + B + C + E
- 5 = Option A + B + D + E
- 6 = Option A + C + D + E
- 7 = Option B + C + D + E
- 8 = Option A + B + C + D + E

### **15: ELECTRICAL ACCESSORIES**

- 0 = Standard
- B = Phase & Brown Out Protection
- C = Air Disinfection UV Lights
- E = Compressor Sound Blankets
- K = Option B + C
- M = Option B + E
- P = Option C + E
- Z = Option B + C + E

### **Feature 16: UNIT CONTROLS**

#### **16A: CONTROL SEQUENCE**

- 0 = Standard Terminal Block for Thermostat
- A = Terminal Block for Thermostat + Isolation Relays
- B = Single Zone VAV Unit Controller - VAV Cool + CAV Heat
- C = Single Zone VAV Unit Controller - VAV Cool + VAV Heat
- D = VAV Unit Controller - VAV Cool + CAV Heat
- E = Constant Air Volume Unit Controller - CAV Cool + CAV Heat
- F = Makeup Air Unit Controller
- M = Field Installed DDC Controls by Others
- N = Field Installed DDC Controls + Isolation Relays
- P = Factory Installed DDC Controls by Others + Isolation Relays
- Q = DX-DOAS Controls

#### **16B: CONTROL SUPPLIER**

- 0 = Standard
- A = AAON Controls
- C = AAON Controls Supervisory

#### **16C: CONTROL SUPPLIER OPTIONS**

- 0 = Standard

#### **16D: BMS CONNECTION & DIAGNOSTICS**

- 0 = None
- B = BACnet MSTP
- K = BACnet MSTP with Diagnostics

## RZ Series Feature String Nomenclature

GEN	MREV	SIZE	SERIES	MNREV	VLT	A1	A2	A3	A4	A5	B1	B2	B3	B4	B5	1	2	3A	3B	3C	3D	3E	4A	4B	4C	5A	5B	5C	5D	5E	6A	6B	6C	6D	6E	7	8	9A	9B	9C	9D
RZ	A	- 145	- D	0	- 3	- C	A	B	0	A	- 0	0	0	0	0	:	N	0	- A	A	K	A	Q	- J	0	0	- B	F	T	O	M	- 0	0	0	0	0	- C	F	- A	0	A
				- 0	0	- M	0	- C	- 0	0	0	- 8	0	- D	A	0	B	- 0	0	- 0	0	0	- A	B	E	Q	0	A	- E	0	0	0	0	0	- C	0	0	0	I	B	
				10A	10B	11A	11B	12	13A	13B	13C	14	15	16A	16B	16C	16D	17A	17B	18A	18B	18C	19	20	21	22	23	24	25	26	27	28	29	30	31	32	33	34	35	36	37

### **Feature 17: PREHEAT OPTIONS**

#### **17A: PREHEAT CONFIGURATION**

- 0 = No Preheat
- F = Hot Water Coil Preheat in Option Box
- G = Steam Distributing Coil Preheat in Option Box
- M = Polymer Coated Hot Water Coil Preheat in Option Box
- N = Polymer Coated Steam Distributing Coil Preheat in Option Box
- P = Direct Fired Heat 100% OA Nat Gas (CAV)

#### **17B: PREHEAT SIZING**

- 0 = No Preheat

#### **Hot Water Preheat Coil [17A = F, M]**

- A = Size A 1 Row Half Serpentine 10 FPI
- B = Size B 1 Row Half Serpentine 10 FPI
- C = Size C 1 Row Half Serpentine 10 FPI
- D = Size D 1 Row Half Serpentine 10 FPI
- E = Size A 1 Row Quarter Serpentine 10 FPI
- F = Size B 1 Row Quarter Serpentine 10 FPI
- G = Size C 1 Row Quarter Serpentine 10 FPI
- H = Size D 1 Row Quarter Serpentine 10 FPI
- J = Size A 2 Row Full Serpentine 10 FPI
- K = Size B 2 Row Full Serpentine 10 FPI
- L = Size C 2 Row Full Serpentine 10 FPI
- M = Size D 2 Row Full Serpentine 10 FPI
- N = Size A 2 Row Half Serpentine 10 FPI
- P = Size B 2 Row Half Serpentine 10 FPI
- Q = Size C 2 Row Half Serpentine 10 FPI
- R = Size D 2 Row Half Serpentine 10 FPI

#### **Steam Distributing Preheat Coil [17A = G, N]**

- A = Size A 1 Row Full Serpentine 10 FPI
- B = Size B 1 Row Full Serpentine 10 FPI
- C = Size C 1 Row Full Serpentine 10 FPI
- D = Size D 1 Row Full Serpentine 10 FPI
- J = Size A 2 Row Full Serpentine 10 FPI
- K = Size B 2 Row Full Serpentine 10 FPI
- L = Size C 2 Row Full Serpentine 10 FPI
- M = Size D 2 Row Full Serpentine 10 FPI

### **Direct Fired Heat [17A = P]**

- A = 1' Burner
- B = 1.5' Burner
- C = 2' Burner
- D = 2.5' Burner
- E = 3' Burner
- F = 4' Burner
- G = 4.5' Burner
- H = 5.5' Burner
- J = 6' Burner
- K = 7' Burner
- L = 7.5' Burner
- M = 8.5' Burner

### **Feature 18: OPTION BOXES**

#### **18A: BOX LOCATION**

- 0 = No Option Box
- A = One Option Box after Return
- B = One Option Box after Pre-Filter
- C = One Option Box after Cooling
- D = One Option Box after Supply Fan
- E = One Option Box after Heat
- F = One Option Box after Return + One after Pre- Filter
- G = One Option Box after Return + One after Cooling
- H = One Option Box after Return + One after Supply Fan
- J = One Option Box after Return + One after Heat
- K = One Option Box after Pre-Filter + One after Cooling
- L = One Option Box after Pre-Filter + One after Supply Fan
- M = One Option Box after Pre-Filter + One after Heat
- N = One Option Box after Cooling + One after Supply Fan
- P = One Option Box after Cooling + One after Heat
- Q = One Option Box after Supply Fan + One after Heat
- R = Additional Vestibule
- S = 2 ft First Box
- T = 2 ft First Box + 2ft Second Box
- U = 2 ft First Box + 4ft Second Box
- V = 2 ft First Box + 6ft Second Box
- W = 2 ft First Box + 8ft Second Box
- Y = 2 ft First Box + 8ft Second Box

## RZ Series Feature String Nomenclature

GEN	MREV	SIZE	SERIES	MNREV	VLT	A1	A2	A3	A4	A5	B1	B2	B3	B4	B5	1	2	3A	3B	3C	3D	3E	4A	4B	4C	5A	5B	5C	5D	5E	6A	6B	6C	6D	6E	7	8	9A	9B	9C	9D	
RZ	A	- 145	- D	0	- 3	- C	A	B	0	A	- 0	0	0	0	0	:	N	0	- A	A	K	A	Q	- J	0	0	- B	F	T	0	M	- 0	0	0	0	0	- C	F	- A	0	A	A
				- 0	0	- M	0	- C	- 0	0	0	- 8	0	- D	A	0	B	- 0	0	- 0	0	0	- A	B	E	Q	0	A	- E	0	0	0	0	0	- C	0	0	0	0	I	B	
				10A	10B	11A	11B	12	13A	13B	13C	14	15	16A	16B	16C	16D	17A	17B	18A	18B	18C	19	20	21	22	23	24	25	26	27	28	29	30	31	32	33	34	35	36	37	

### 18A: BOX LOCATION Continued

Z = 2 ft First Box + 8ft Second Box  
 1 = 2 ft First Box + 8ft Second Box  
 2 = 2 ft First Box + 8ft Second Box  
 3 = 2 ft First Box + 8ft Second Box  
 4 = 2 ft First Box + 8ft Second Box

### 18B: BOX SIZE

0 = No Option Box  
 A = 2 ft First Box  
 B = 2 ft First Box + 2ft Second Box  
 C = 2 ft First Box + 4ft Second Box  
 D = 2 ft First Box + 6ft Second Box  
 E = 2 ft First Box + 8ft Second Box  
 F = 4 ft First Box  
 G = 4 ft First Box + 2ft Second Box  
 H = 4 ft First Box + 4ft Second Box  
 J = 4 ft First Box + 6ft Second Box  
 K = 4 ft First Box + 8ft Second Box  
 L = 6 ft First Box  
 M = 6 ft First Box + 2ft Second Box  
 N = 6 ft First Box + 4ft Second Box  
 P = 6 ft First Box + 6ft Second Box  
 Q = 6 ft First Box + 8ft Second Box  
 R = 8 ft First Box  
 S = 8 ft First Box + 2ft Second Box  
 T = 8 ft First Box + 4ft Second Box  
 U = 8 ft First Box + 6ft Second Box  
 V = 8 ft First Box + 8ft Second Box

### 18C: BOX ACCESSORIES

0 = None  
 A = 20" Drain Pan in First Box  
 B = 20" Drain Pan in First Box +  
 20" Drain Pan in Second Box  
 C = 20" Drain Pan in First Box +  
 44" Drain Pan in Second Box  
 D = Option A + Sound Attenuator  
 E = 44" Drain Pan in First Box  
 F = 44" Drain Pan in First Box +  
 20" Drain Pan in Second Box

### 18C: BOX ACCESSORIES (cont.)

G = 44" Drain Pan in First Box + 44" Drain Pan in  
 Second Box  
 H = Option E + Sound Attenuator  
 J = Sound Attenuator in First Box  
 K = Option J + 20" Drain Pan in Second Box  
 L = Option J + 44" Drain Pan in Second Box  
 M = Sound Attenuator in First Box + Sound  
 Attenuator in Second Box  
 N = Empty First Box + 20" Drain Pan in Second  
 Box  
 P = Empty First Box + 44" Drain Pan in Second  
 Box  
 Q = Empty First Box + Sound Attenuator in  
 Second Box  
 S = Air Mixer in First Box  
 T = Option S + 20" Drain Pan in Second Box  
 U = Option S + 44" Drain Pan in Second Box  
 V = Option S + Sound Attenuator in Second Box

### 19: OUTSIDE AIR ACCESSORIES

0 = No Outside Air Hood 100% Return Air  
 A = Outside Air Hood  
 B = Outside Air Hood with Metal Mesh Filters  
 C = Outside Air Hood + Outside Air Flow Measuring  
 Station  
 G = Option B + C

### 20: CABINET OPTIONS

0 = Standard  
 B = SA & RA Burglar Bars  
 C = SA & RA Walkable Safety Grates  
 D = Perforated Line for SA Fans  
 E = Perforated Liner for RA Fans  
 L = Option B + D  
 M = Option B + E  
 Q = Option D + E  
 I = Option B + D + E

## RZ Series Feature String Nomenclature

GEN	MJREV	SIZE	SERIES	MNREV	VLT	A1	A2	A3	A4	A5	B1	B2	B3	B4	B5	1	2	3A	3B	3C	3D	3E	4A	4B	4C	5A	5B	5C	5D	5E	6A	6B	6C	6D	6E	7	8	9A	9B	9C	9D		
RZ	A	- 145	- D	0	- 3	- C	A	B	0	A	- 0	0	0	0	0	:	N	0	- A	A	K	A	Q	- J	0	0	- B	F	T	0	M	- 0	0	0	0	0	- (	C	F	- /	0	/	A
				- 0	0	- M	0	- C	- 0	0	0	- 8	0	- D	A	0	B	- 0	0	- 0	0	0	- A	B	E	Q	0	A	- E	0	0	0	0	0	- (	0	0	(	0	I	B		
				10A	10B	11A	11B	12	13A	13B	13C	14	15	16A	16B	16C	16D	17A	17B	18A	18B	18C	19	20	21	22	23	24	25	26	27	28	29	30	31	32	33	34	35	36	37		

### **21: ACCESSORIES**

- 0 = None
- B = Motorized Service Vestibule Fresh Air
- C = Supply Fan Air Flow Measuring
- D = Return Fan Air Flow Measuring
- E = Access Door Windows
- K = Option B + C
- L = Option B + D
- M = Option B + E
- N = Option C + D
- P = Option C + E
- Q = Option D + E
- Y = Option B + C + D
- Z = Option B + C + E
- 1 = Option B + D + E
- 2 = Option C + D + E
- 7 = Option B + C + D + E

### **22: MAINTENANCE ACCESSORIES**

- 0 = Standard
- A = Factory Wired 115V Convenience Outlet
- B = Field Wired 115V Convenience Outlet
- C = Service Lights
- D = Remote Start/Stop contacts
- E = Supply Fan Auxiliary Contacts
- F = Option A + C
- G = Option A + D
- H = Option A + E
- J = Option B + C
- K = Option B + D
- L = Option B + E
- M = Option C + D
- N = Option C + E
- P = Option D + E
- Q = Option A + C + D
- R = Option A + C + E
- S = Option A + D + E
- T = Option B + C + D
- U = Option B + C + E
- V = Option B + D + E
- W = Option C + D + E
- Y = Option A + C + D + E
- Z = Option B + C + D + E

### **23: CODE OPTIONS**

- 0 = Standard - ETL U.S.A. Listing
- A = Chicago Code
- B = ETL U.S.A. + Canada Listing

### **24: SHIPPING SPLITS**

- 0 = Standard
- A = Two Piece Unit
- D = Two Piece Unit (Refrigeration Split)

### **25: AIR COOLED CONDENSER**

#### **ACCESSORIES**

- 0 = Standard
- E = VFD Condenser Fan Head Pressure Control
- K = Low Sound Condenser Fan Head Pressure Control

### **26: EVAPORATIVE CONDENSER ACCESSORIES**

- 0 = No Evaporative Condenser
- A = No Sump or Vestibule Heater
- B = Sump & Vestibule Heaters

### **27: WATER - COOLED CONDENSER**

#### **ACCESSORIES**

- 0 = No Water-Cooled Condenser

### **28: ENERGY RECOVERY WHEEL**

#### **ACCESSORIES**

- 0 = None
- A = Energy Recovery Wheel Defrost Start/Stop
- B = Energy Recovery Wheel Rotation Detection
- E = VFD for Heat Wheel Motor (Field Control)
- F = Energy Recovery Wheel Defrost Start/Stop
- M = Option B + E

### **29: VFD OPTIONS**

- 0 = None
- A = Shaft Grounding Kit on all SA, RA, EA Motors
- C = BACnet VFD on all Motors
- G = Option A + C

## RZ Series Feature String Nomenclature

GEN	MREV	SIZE	SERIES	MNREV	VLT	A1	A2	A3	A4	A5	B1	B2	B3	B4	B5	1	2	3A	3B	3C	3D	3E	4A	4B	4C	5A	5B	5C	5D	5E	6A	6B	6C	6D	6E	7	8	9A	9B	9C	9D	
RZ	A	- 145	- D	0	- 3	- C	A	B	0	A	- 0	0	0	0	0	:	N	0	- A	A	K	A	Q	- J	0	0	- B	F	T	0	M	- 0	0	0	0	0	- C	F	- 1	0	1	A
				- 0	0	- M	0	- C	- 0	0	0	- 8	0	- D	A	0	B	- 0	0	- 0	0	0	- A	B	E	Q	0	A	- E	0	0	0	0	0	- C	0	0	0	0	1	B	
				10A	10B	11A	11B	12	13A	13B	13C	14	15	16A	16B	16C	16D	17A	17B	18A	18B	18C	19	20	21	22	23	24	25	26	27	28	29	30	31	32	33	34	35	36	37	

**30: MISCELLANEOUS OPTIONS**

- 0 = None
- A = High Condensate Level Switch
- S = Additional Vestibule Heater
- T = Option A + S

**31: BLANK**

- 0 = Standard

**32: BLANK**

- 0 = Standard

**33: BLANK**

- 0 = Standard

**34: BLANK**

- 0 = Standard

**35: WARRANTY**

- 0 = Standard Warranty
- A = 2 Year Parts Warranty
- B = 5 Year Parts Warranty
- C = 10 Year Parts Warranty

**36: CABINET Material**

- D= Galvanized Cabinet – Double Wall + R-13 Foam Insulation + 6” Base Rail + Double Sloped Roof

**37: SPECIALS & PAINT**

- B = Premium AAON Gray Paint Exterior
- D = Premium AAON Gray Paint Exterior + Interior Corrosion Protection
- G = Premium AAON Gray Paint Exterior + Interior Corrosion Protection + Shrink Wrap
- X = SPA + Premium AAON Gray Paint Exterior
- Z = SPA + Premium AAON Gray Paint Exterior + Interior Corrosion Protection
- 3 = SPA + Premium AAON Gray Paint Exterior + Interior Corrosion Protection + Shrink Wrap
- 4 = SPA + Special Exterior Paint Color
- 6 = SPA + Special Exterior Paint Color + Interior Corrosion Protection
- 9 = SPA + Special Exterior Paint Color + Interior Corrosion Protection + Shrink Wrap

## General Information

RZ Series packaged rooftop and outdoor air handling units are for outdoor installation only. A minimum of 12" high curb is required for installation on combustible roofs.

### **WARNING**

Improper installation, adjustment, alteration, service or maintenance can cause property damage, personal injury or loss of life. Startup and service must be performed by a Factory Trained Service Technician.

### **CAUTION**

These units must not be used for heating or cooling at any time during any phase of construction. Very low return air temperatures, harmful vapors, and misplacement of the filters will damage the unit and its efficiency.

### Certification of Gas Heat Models

- The RZ Series gas heat exchangers have been certified as a Category III forced air furnace for use with or without cooling, located downstream of the indoor coil.
- AAON gas heat exchangers operate for a minimum of 10,000 cycles.
- Individual RZ Series gas heat exchangers are designed for 400 MBH and 350 MBH input rates and can be configured for up to a 4500 MBH total gas input rating (maximum input rates vary by selected heating feature).

- Modulating gas heat exchangers are designed for 3:1 turndown of the 320 MBH input rate available on the first stage of heating.

### Certification of Steam or Hot Water Heat Models

- Certified as a forced air heating system with or without cooling.
- RZ Series hot water coils are designed for operation with no more than 82.2°C (180°F) water at a 1034 kpa (150 psig) working pressure.
- RZ Series steam coils are designed for 1034 kpa (150 psig) working pressure.

### Certification of Electric Heat Models

- RZ Series electric warm air furnaces have been certified for use with or without cooling, located downstream of the indoor coil.
- RZ Series electric warm air furnaces are designed with individual 40 KW electric heating elements that can be configured for up to 240 KW of electric heat (maximum output varies by selected heating features).
- Modulating electric heat exchangers are equipped with Silicon Control Rectifiers (SCR) on the first stage of heating.

### Certification of Cooling Models

- RZ Series R-410A refrigerant systems have been certified as commercial central air conditioners with or without electrically operated compressors.
- RZ Series chilled water coils are designed for 1034 kpa (150 psig) working pressure.

## Codes and Ordinances

The RZ Series has been tested and certified by Intertek (ETL) to the following safety standards:

### ANSI Z21.47-2016/CSA 2.3-2016

*Gas-Fired Central Furnaces*

### ANSI Z83.8-2016/CSA 2.6-2016

*Gas unit heaters, gas packaged heaters, gas utility heaters and gas-fired duct furnaces*

### UL 60335-2-40 4<sup>th</sup> Edition 2022

*Safety standard for A2L units*

System must be sized in accordance with practices described in the American Society of Heating, Refrigeration, and Air Conditioning Engineers Handbooks.

AAON equipment must be installed in accordance with this manual and the International Code Council (ICC) requirements.

Installation of RZ Series units must conform to the International Code Council (ICC) standards of the International Mechanical Code, the International Building Code, and local building, plumbing, and waste water codes. In the absence of local codes installation must conform to current National Fuel Code ANSI Z223.1/NFPA 54 or the National Gas & Propane Installation Code CSA B149.1, and CSA B52 Mechanical Refrigeration Code. All appliances must be electrically grounded in accordance with local codes, or in the absence of local codes, the National Electric Code, ANSI/NFPA 70, and/or the Canadian Electrical Code CSA C22.1.

## CAUTION

The Clean Air Act of 1990 bans the intentional venting of refrigerant as of July 1, 1992. Approved methods of recovery, recycling, or reclaiming must be followed.

## WARNING

Coils and sheet metal surfaces present sharp edges and care must be taken when working with this equipment.

## WARNING

Failure to observe the following instructions will result in premature failure of your system and possible voiding of the warranty.

### Receiving Unit

When received, the unit must be checked for damage that might have occurred in transit. If damage is found, it must be noted on the carrier's Freight Bill. A request for inspection by carrier's agent must be made in writing at once. Nameplate must be checked to ensure the correct model sizes and voltages have been received to match the job requirements.

If repairs must be made to damaged goods, notify the factory before any repair action is taken in order to protect the warranty. Certain equipment alteration, repair, and manipulation of equipment without the manufacturer's consent may void the product warranty. Contact the AAON Warranty Department for assistance with handling damaged goods, repairs, and freight claims: (918) 382-6450.

**Note:** Upon receipt check shipment for items that ship loose such as filters and remote sensors. Consult order and shipment documentation to identify potential loose-shipped items. Loose-shipped items may have been placed inside unit cabinet for security. Installers and owners must secure

all doors with locks or nuts and bolts to prevent unauthorized access.

### Storage

If installation will not occur immediately following delivery, store equipment in a dry protected area away from construction traffic and in the proper orientation as marked on the packaging with all internal packaging in place. Secure all loose-shipped items. Refer to Table 15 for minimum floor areas if unit is stored in an unventilated space.

### Access Doors

Lockable access doors are provided to the services vestibule and to sections of the unit which may require maintenance or servicing. After startup is completed, if necessary, use locks to prevent unauthorized access.

A separate access door is also provided to the evaporator and pumping package compartment. See maintenance section for information on leak checking these doors.

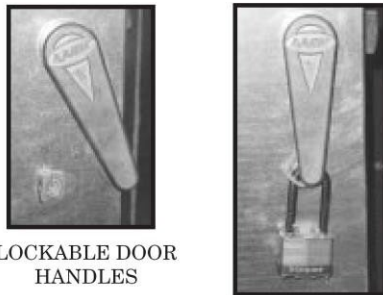

Figure 1- Lockable Door Handles

### Wiring Diagrams

Unit specific wiring diagrams are laminated and affixed inside the controls compartment door.

### Installation

AAON equipment is designed to be easily installed and serviced.

### Locating Units

The curb must be mounted first and must be located so that duct connections will be clear of structural members of the building.

Verify rooftop or foundation can support the total unit weight, including accessory weights.

**! WARNING**

When locating gas fired units, the unit shall be installed so that the flue discharge vents are located at least 305 cm (120 inches) away from any opening through which combustion products could enter the building.

Do not position flue opening to discharge into a fresh air intake of any other piece of equipment. Unit must also be installed so that the flow of combustion intake air is not obstructed from reaching the furnace.

**! WARNING**

Distances from adjacent public walkways, adjacent buildings, operable windows and building openings, shall conform to local codes and/or the National Fuel Gas Code, ANSI Z223.1/NFPA 54, or the National Gas & Propane Code, CSA B149.1

Vent opening must not be blocked by snow. A minimum 30.5 cm (12”) curb must be used or the vent outlet shall be greater than 30.5 cm (12”) off the ground/roof.

Flue gas is dangerously hot and contains containments. The user is responsible for



determining if vent gases may degrade building materials.

The National Gas and Propane Installation Code, B149.1 specifies a 1.8m (6ft). horizontal vent terminal clearance to gas and electric meters and relief devices.

Local codes may supersede or further place restrictions on vent termination locations.

Table 1 - Air-Cooled Condenser Unit Clearances 45-240 ton

Location	Clearance for 45-240 ton units
Front (Condenser Side)	152cm (60")
Back (Outside Air)	254 cm (100")
Left	254 cm (100")
Right	254 cm (100")
Top	Unobstructed



Figure 2 - RZ Series Unit Orientation

Table 2 - Evaporative Condenser Unit Clearances 45-240 ton

Location	Clearance for 45-240 ton units
Front (Condenser Side)	254 cm (100")
Back (Outside Air)	254 cm (100")
Left	254 cm (100")
Right	254 cm (100")
Top	Unobstructed

Condenser coils and fans must be free of any obstructions in order to start and operate properly with a correct amount of airflow.

For proper unit operation, the immediate area around the condenser must remain free of

debris that may be drawn in and obstruct airflow in the condensing section.

Consideration must be given to obstruction caused by snow accumulation when placing the unit.

### Curb Installation

Make openings in the roof decking large enough to allow for duct penetrations and workspace only. Do not make openings larger than necessary. Set the curb to coincide with the openings. Make sure curb is level. Unit must be level in both horizontal axes to support the unit and reduce noise and vibration.

Unit specific curb drawing is included with job submittal. See SMACNA *Architectural Sheet Metal Manual* and *HVAC Duct Construction Standards* for curb installation details.

**! CAUTION**

All roofing work must be performed by competent roofing contractors to avoid any possible leakage.

**! CAUTION**

Where the supply or warm air duct passes through a combustible roof, a clearance of 2.54cm (1 inch) must be maintained between the outside edges of the duct and combustible material in accordance with National Fire Protection Association Standard No. 90A. Provide flashings or enclosure between structure and roof and all joints must be sealed with mastic roofing to ensure a watertight seal.

For horizontal return and discharge applications, total height of mounting rail and unit base rail must be high enough so that adequate condensate drain p-trap can be included. Units require steel mounting rail support along all four sides of the unit base.

When installed at ground level, a one-piece concrete slab must be used with footings that extend below the frost line. Care must also be taken to protect the coil and fins from damage due to vandalism or other causes.

If unit is elevated a field supplied catwalk is recommended to allow access to unit service doors.

This unit ships with a curb gasket that is 31 ¾ mm ( 1¼”) wide and 38 mm (1½”) tall. This or another similar gasket must be used between the curb and the unit to reduce vibration from the unit to the building.

### Lifting the Unit

 <b>CAUTION</b>
<b>Incorrect lifting can cause damage to the unit.</b>

If cables or chains are used to hoist the unit they must be the same length. See Figure 4 and Figure 5 for dimensions.

Lift the unit with the outside air hood in the downward shipping position. However, the unit may be lifted with the outside air hood in the open position.

Before lifting unit, be sure that all shipping material has been removed from the unit. Secure hooks and cables at all marked lifting points provided on the unit.

Hoist unit to a point directly above the curb and duct openings. Be sure that the gasket material has been applied to the curb.

Carefully lower and align unit with utility and duct openings. Lower the unit until the unit skirt fits around the curb. Make sure the unit is properly seated on the curb and is level.

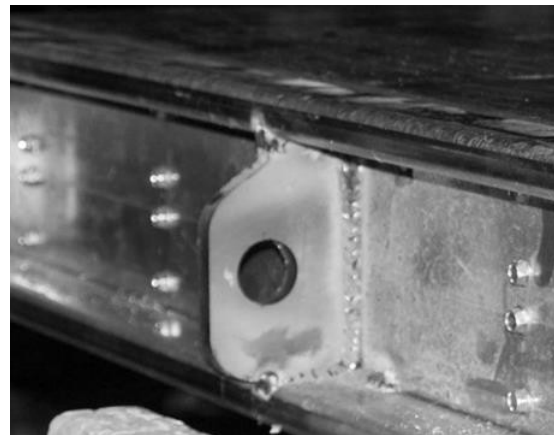

Figure 3 - Base Rail Lifting Lug

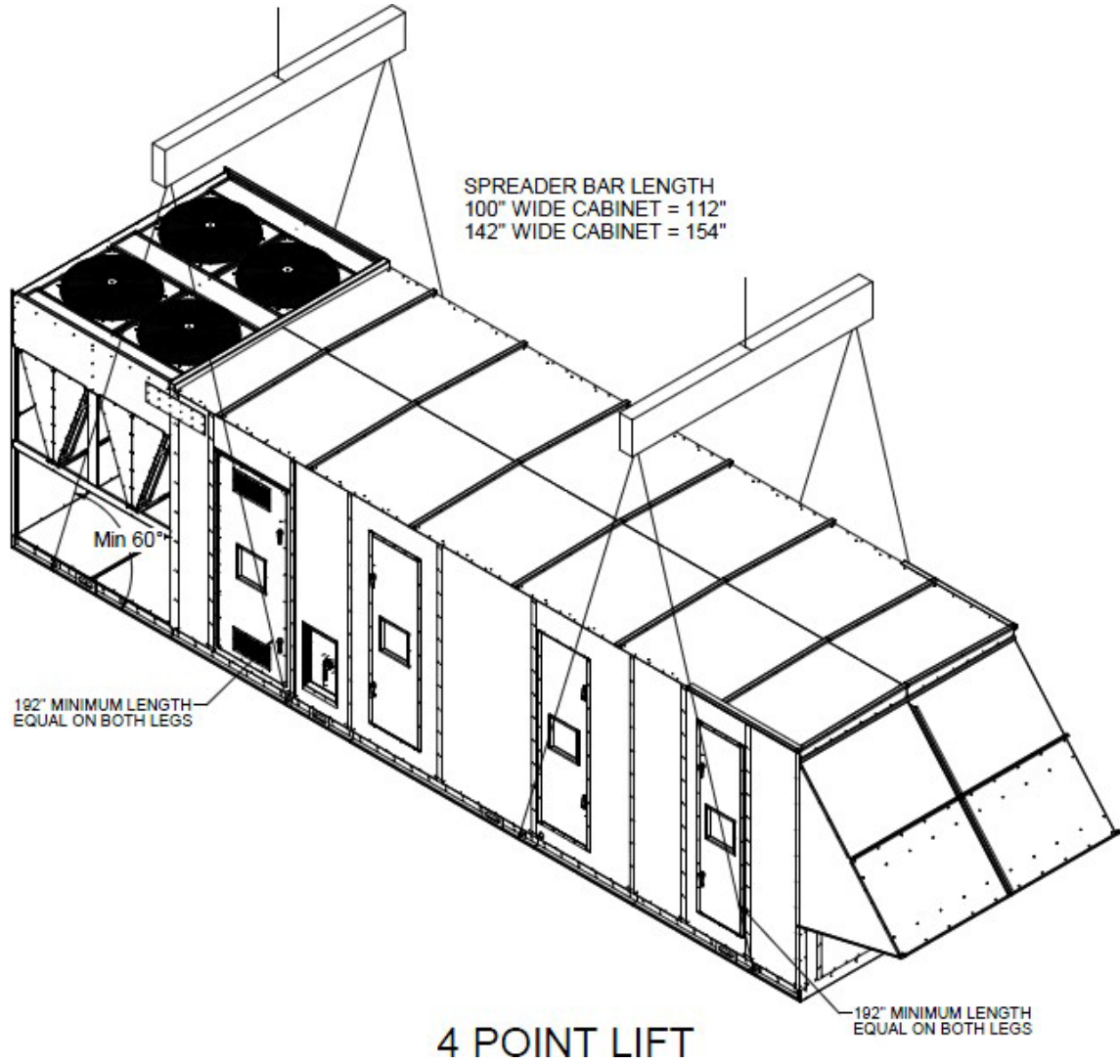

Figure 4 - 4 Point Lift RZ Series Air-Cooled Condenser Unit

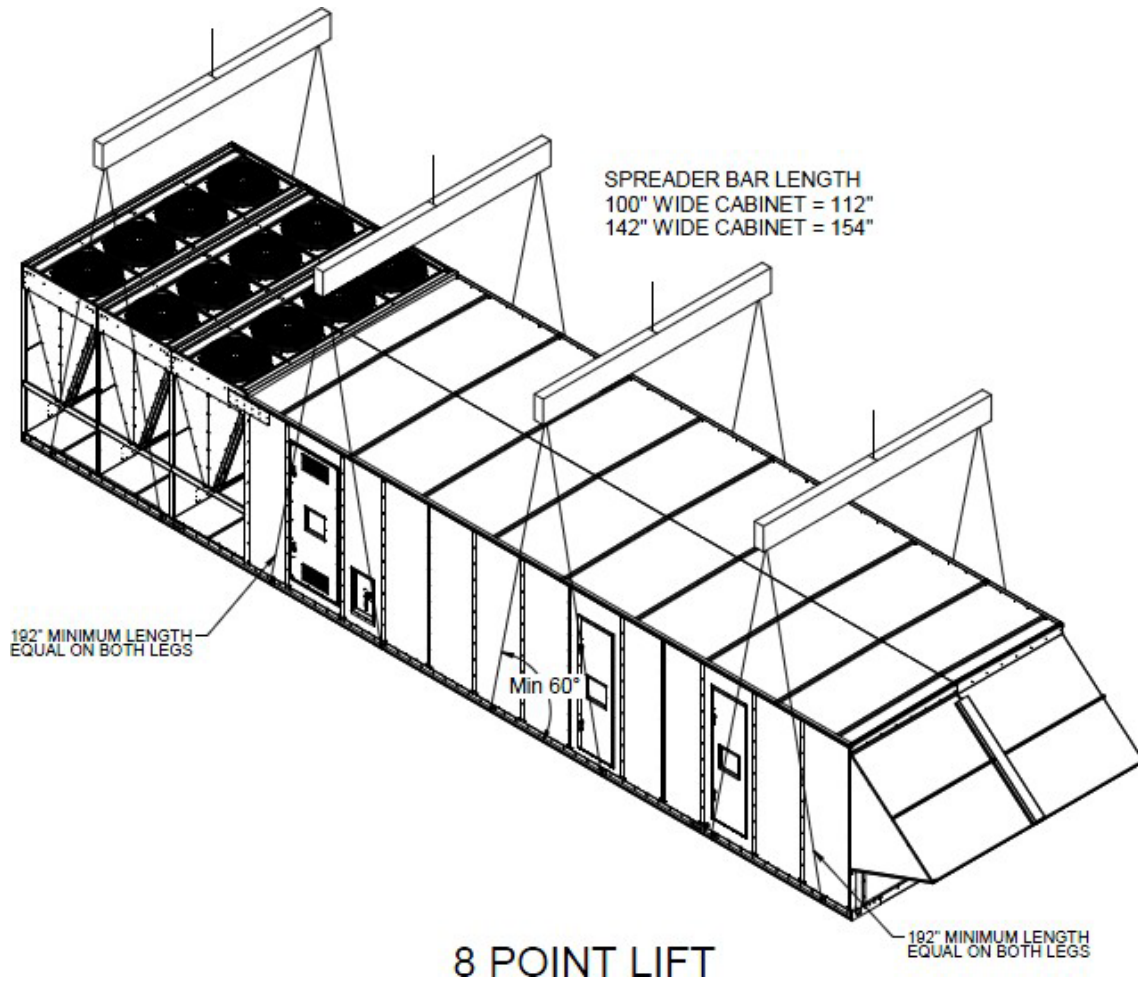

Figure 5 - 8 Point Lift RZ Series Air-Cooled Condenser Unit

**Lifting slot locations are unit specific.  
 Unit must be rigged at all marked lifting points.**

### Duct Connection

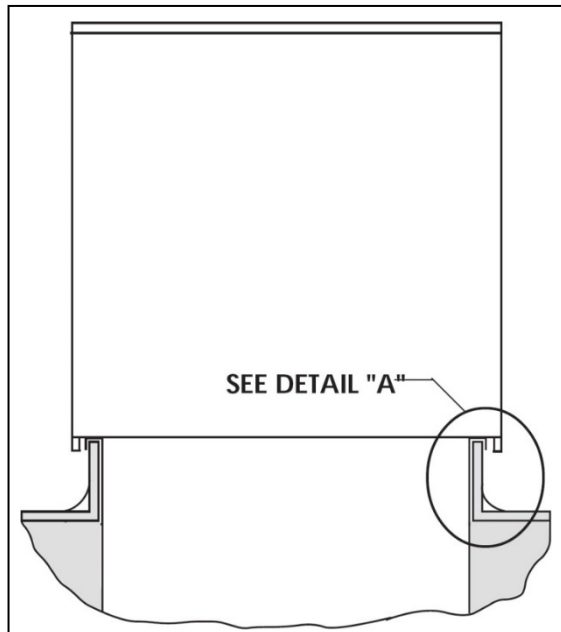

Figure 6 - Curb Mounting

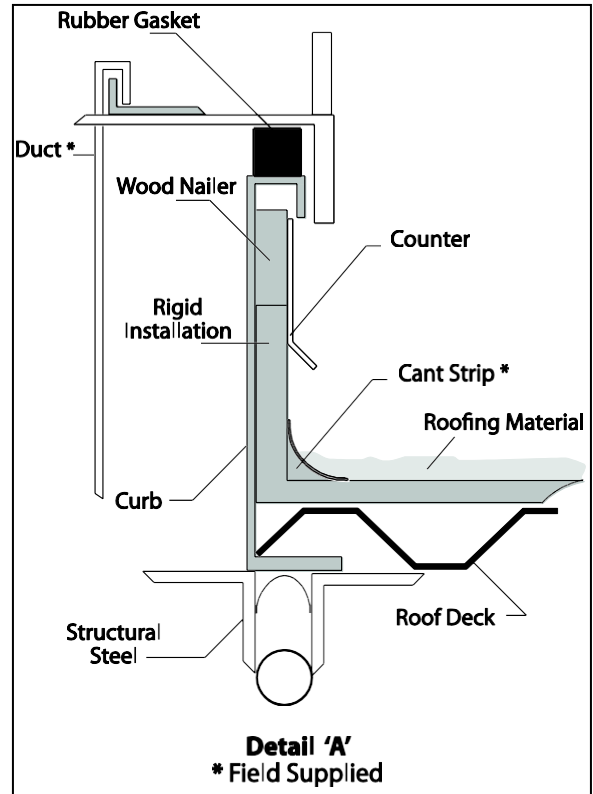

Figure 7 - Curb Detail

Table 3 - Mounting Dimensions

Tons	A m (ft)	B m (ft)	C m (ft)	D m (ft)
45-140	2.5 (8.3)	2.4 (8.0)	2.3 (7.7)	2.5 (8.1)
145-240	3.6 (11.8)	3.5 (11.5)	3.4 (11.2)	3.5 (11.6)

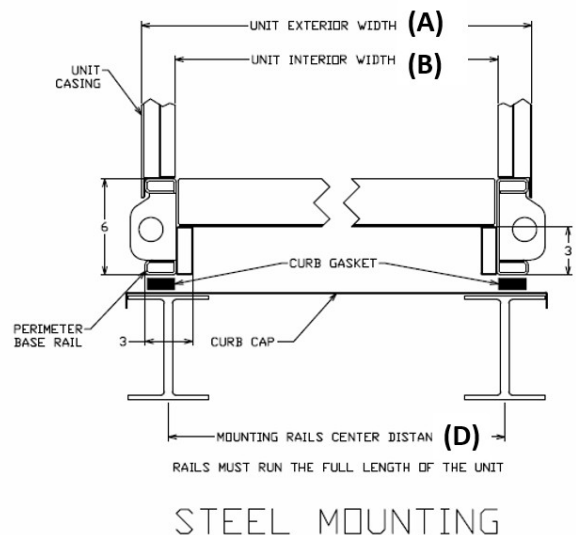
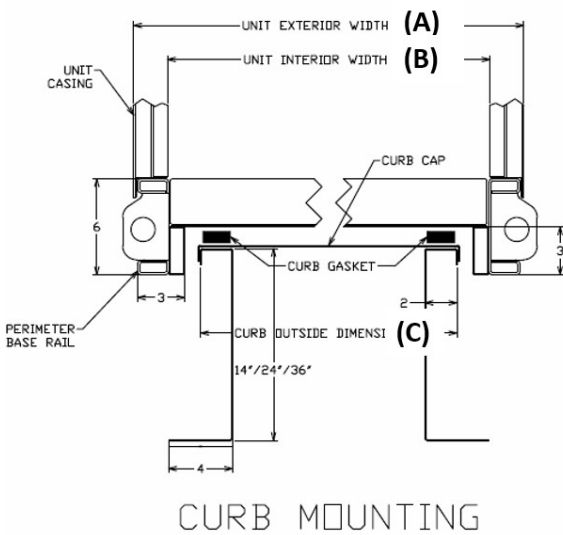

Figure 8 - Curb & Steel Mounting Rail with Dimensions

## Reassembling Split Units

Some RZ Series units are built and shipped in two separate sections.

Shipping covers must be removed from the ends where the sections will connect.

Lift and set the largest section first, checking for the correct location and position.

In order to simplify the connection of the two sections, it is important to position and set the second section as close as possible to the first section. This will allow the use of a come-along tool, to pull the second section against the first section. One come-along tool is required on each side of the unit, connected at the base slots. The two sections must be tightly adjoined before the splicing parts can be installed.

All parts required for splicing the sections together are factory provided. Neoprene gasket is provided to be applied on ends of both sections.

Once the unit is completely assembled, it is important to visually inspect all exposed areas and fill any gaps with butyl caulking.

### Splicing

1. Align base rail and side sections.
2. Check roof alignment and connecting flange.
3. Fill post seam with butyl caulking. Apply butyl caulking between roof flange sections.
4. Attach splice plate to outside of post to cover seam. Splice plate is typically required on both sides of the unit.
5. Install factory provided roof splice cap over the two sections connecting flange and secure with screws along the length of the cap.

6. Apply butyl caulking to all seams and perimeter of splice and to the perimeter of the roof splice cap against the roof of the unit.

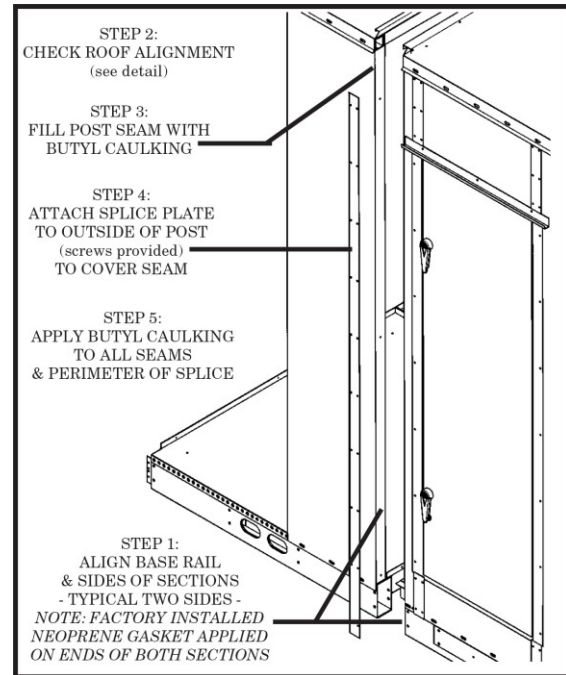

Figure 9 - Unit Base and Sides

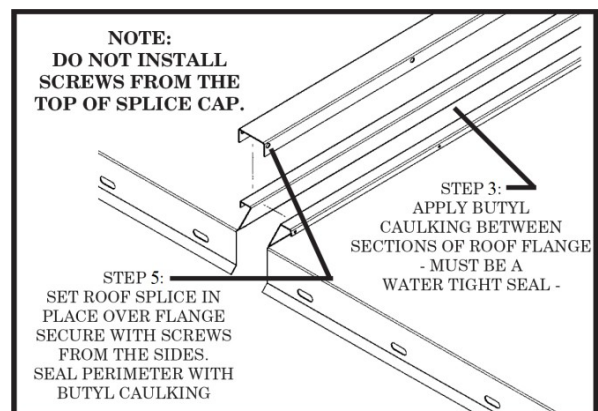
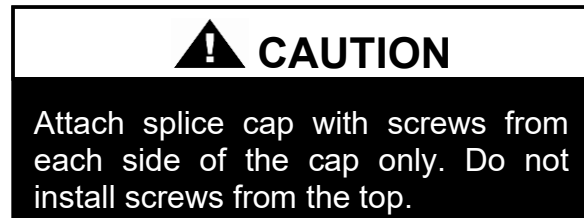

Figure 10 - Unit Roof Flange Splice Detail

### *Refrigeration Split Installation Procedure*

If a given unit is too large to be shipped on one truck bed, the unit must be split. If the condenser side of the split is too long, a split is required in the refrigeration system. Each side of the split will have isolation valves; one isolation valve is connected to the condenser side, while the other is connected to the evaporator side. Keep these **isolation valves closed** until the following assembly procedure is complete.

**Caution**, the refrigeration lines between the isolation valve and cap at the unit split are charged with 689.5 kpa (100 psi) of nitrogen.

1. Relieve the pressure in the refrigeration split that is charged with nitrogen by attaching a gauge manifold set and purging through the hoses.

2. Next remove the copper caps on each side by using a pipe cutter at the brazed joint (Joint A and B).
3. Then braze the provided copper lines onto their respective open lines.
4. After the lines are joined, charge the newly joined section with 1.28 Mpa (200 psi) of dry nitrogen. Test the charge for an hour. After one hour and no pressure loss, relieve the pressure by removing the Schrader core. Replace Schrader core once all pressure is relieved.
5. Next evacuate out each section of connection piping from valve to valve to 400 microns. The micron gauge must not rise above 500 microns after 30 minutes of wait time.
6. Finally open the isolation valves. The unit is shipped with the correct refrigerant charge.

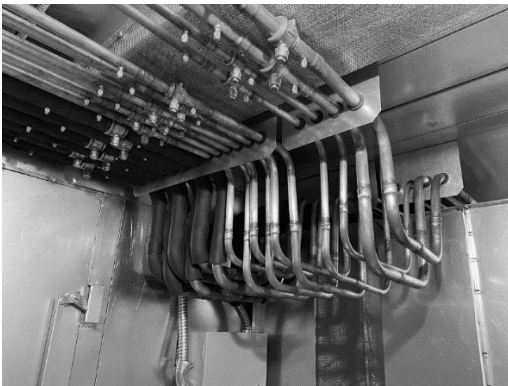
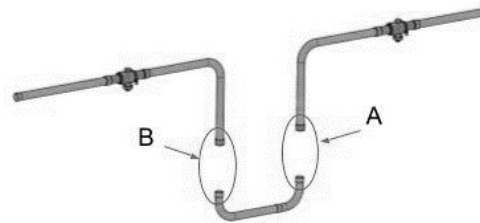

Figure 11 - Staggered assembly for refrigeration pipes



### *Electrical Connection of Split Units*

Before attempting to make wire connections between sections it is important to refer to the unit specific wiring diagram located in the unit controls compartment to obtain additional details related to the wiring of the specific unit.

Adjoining sections are factory wired and ready for field connection. The electrical wiring is unit specific and designed according to the overall unit configuration.

A factory supplied and mounted terminal block is located in the main section of the unit that must be used in making the rough-in wire connections.

Each wire being spliced from section to section is tagged at both ends according to its termination. Junctions for wiring these sections together are separated according to voltage.

Ensure that wires are protected from damage and wear caused by normal operation of the unit and environmental factors.

 <b>CAUTION</b>
All wire terminations <b>MUST BE</b> made before applying power to the unit. The unit will not operate unless all circuits are made.

### **Outside Air Rain Hood**

For proper unit operation, the outside air hood must be opened at start-up as shown in Figure 12.

Locate the middle support for the outside air rain hood inside of the unit and remove shipping screws from each side of the closed hood.

Lift hood outward to the open position and secure with sheet metal screws. Then place the middle support connecting the middle of

the hood to the unit and secure with sheet metal screws. Apply butyl caulking along the top and both sides of the rain hood. Take care to seal the top corners where the rain hood attaches to the unit. Outdoor air intake adjustments must be made according to building ventilation or local code requirements.

Air hoods vary according to unit size and options. Figure 12 below is shown as a practical guideline for all outside air rain hoods.

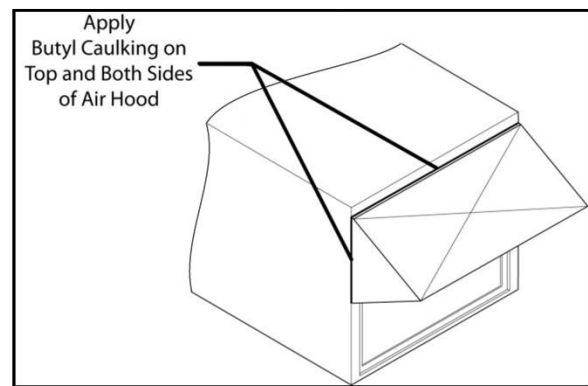

Figure 12 - Air Hood Shown in the Open Position

### **End Flashing Installation**

On RZ Series D and E cabinet units which are 360.7 cm (142") wide (RZ-145, 160, 180, 200, 220, 240) the cabinet width will overhang the trailer on each side.

In order to secure and protect the unit during transit the sheet metal end flashings have been removed from the unit. The slot created at the base of each end of the unit allows the unit to set firmly on the trailer deck.

Sheet metal flashings are shipped loose with the unit and once the unit is set into place the flashings must be installed on each end of the unit to complete the finished seal at the base. The flashings are unit specific and designed to cover the slot at each end of the unit to prevent water run-off into the curb.



Failure to attach and seal the end of unit with the flashings will result in water leakage into the curb.

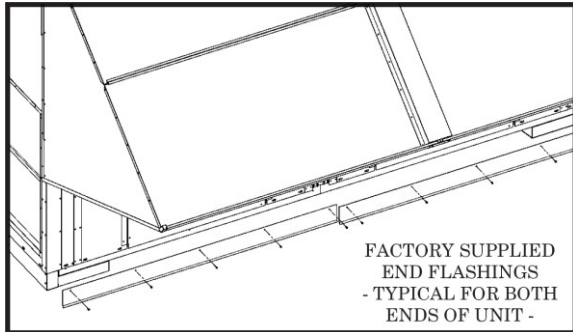

Figure 13 - Factory Supplied End Flashings

**! CAUTION**

In order to prevent water leakage into the roof curb, the factory provided sheet metal flashings **MUST BE** attached to the unit base to cover the shipping slots at both ends of the unit.

### Vestibule Exhaust Fan

Prior to unit operation of units with service vestibules the exhaust fan shipping support must be removed from the exterior of the unit.

The exhaust fan also includes a factory provide exterior rain hood which must be installed.



Figure 14 - Vestibule Exhaust Fan

### Motorized Exhaust & Rain Hood

**Narrow (254 cm [100"])** – The motorized exhaust damper and rain hood ships inside of the return air section. For proper unit operation, the motorized exhaust damper must be installed in the field. Once the motorized exhaust is screwed into place and has been sealed with butyl caulking, attach a rain hood above the motorized exhaust. Upon screwing the rain hood into place over the motorized exhaust, apply a seal of butyl caulking around the edges of the rain hood.

**Wide (360 cm [142"])** – The RZ unit will arrive with the motorized exhaust already in place. The rain hood ships inside of the return air section and must be field installed. After screwing the rain hood over the motorized exhaust with sheet metal screws, apply a sealant of butyl caulking.

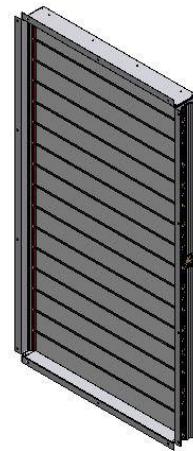

Figure 15 - Motorized Exhaust

## Electrical

Verify the unit nameplate agrees with power supply. Connect power and control field wiring as shown on the unit specific wiring diagram provided laminated and attached to the door in the controls compartment.

Table 4 - Nameplate Voltage Markings & Tolerances

Hz	Nameplate Voltage	Nominal System Voltage	Operating Voltage Range <sup>1</sup>		Acceptable Performance Range <sup>2</sup>	
			Min	Max	Min	Max
60	115	120	104	127	108	126
	208/230	208/240	187	254	187	252
	208	208	187	228	187	228
	230	240	208	254	216	252
	265	277	240	293	249	291
	460	480	416	508	432	504
	575	600	520	635	540	630
50	230	230	198	254	208	254
	400	400	344	440	360	440

Notes:

1. Operating voltage is the min and max voltage for which the unit can function. Never operate outside of this min and max voltage.
2. The Acceptable Performance Range is the min and max voltage for which the unit performance is designed and rated to give acceptable performance.

Route power and control wiring, separately, through the utility entry in the base of the unit. Do not run power and signal wires in the same conduit.

Size supply conductors based on the unit MCA rating. Supply conductors must be rated a minimum of 75°C (167°F).

Protect the branch circuit in accordance with code requirements. The unit must be electrically grounded in accordance with local codes, or in the absence of local codes, the current National Electric Code, ANSI/NFPA 70 or the current Canadian Electrical Code CSA C22.1.

### WARNING

Electric shock hazard. Before attempting to perform any installation, service, or maintenance, shut off all electrical power to the unit at the disconnect switches. Unit may have multiple power supplies. Failure to disconnect power could result in dangerous operation, serious injury, death or property damage.

### CAUTION

Proper sealing of the electrical and gas entries into the unit must be performed. Failure to seal the entries may result in damage to the unit and property

**Note:** All units are factory wired for 208/230V, 460V, or 575V. If unit is to be connected to a 208V supply, the transformer must be rewired to 208V service. For 208V service interchange the yellow and red conductor on the low voltage control transformer.

Red-Black for 208V  
Yellow-Black for 230V

Wire power leads to the unit's power block or main disconnect. All wiring beyond this point has completed by the manufacturer and cannot be modified without affecting the unit's agency/safety certification.

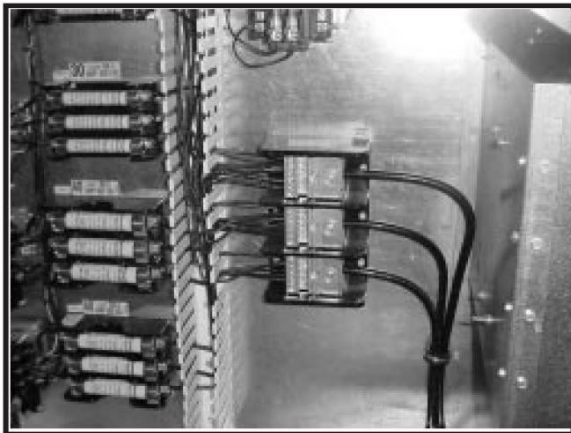



Figure 16 - Power Block

Supply voltage must be within the min/max range shown on the unit nameplate. Available short circuit current must not exceed the short circuit current rating (SCCR) shown on the unit nameplate.

 <b>CAUTION</b>
Three phase voltage imbalance will cause motor overheating and premature failure.

Three phase voltage imbalance will cause motor overheating and premature failure. The maximum allowable imbalance is 2%.

Voltage imbalance is defined as 100 times the maximum deviation from the average voltage divided by the average voltage.

Example:

$$(221V+230V+227V)/3 = 226V, \text{ then}$$
$$100*(226V-221V)/226V = 2.2\%, \text{ which}$$

exceeds the allowable imbalance.

Check voltage imbalance at the unit disconnect switch and at the compressor terminal. Contact your local power company for line voltage corrections.

Installing contractor must check for proper motor rotation and check blower motor amperage listed on the motor nameplate is not exceeded. Motor overload protection may be a function of the variable frequency drive and must not be bypassed.

 <b>CAUTION</b>
Rotation must be checked on all <b>MOTORS AND COMPRESSORS</b> of three phase units. Supply fan, exhaust fan, return fan, and condenser fan motors must all be checked by a qualified service technician at startup and any wiring alteration must only be made at the unit power connection.
Variable frequency drives are programmed to automatically rotate the fan in the correct rotation. Do not rely on fans with variable frequency drives for compressor rotation.

Wire control signals to the unit's low voltage terminal block located in the controls compartment.

**! CAUTION**

Scroll compressors are directional and will be damaged by operation in the wrong direction. Low pressure switches on compressors have been disconnected after factory testing. Rotation must be checked by a qualified service technician at startup using suction and discharge pressure gauges and any wiring alteration must only be made at the unit power connection.

**Variable Speed Compressors**

Variable speed compressors with VFD speed control are standard on RZ Series units. Variable speed compressors must not be operated below 50 Hz.

**Fuses and Circuit Breakers**

The interrupting rating of fuses and circuit breakers is to be determined based on the KAIC rating of the unit. Refer to the wiring diagram for fuse sizing.

Table 5 – 35 KAIC Fuse Sizing

35 KAIC Construction		
Component	Description	Interrupting Rating (kA)
Fuse	Class CC, 600V, 0.5A - 30A	200
Fuse	Class J, 600V, 35A - 600A	200
Disconnect	3P, 600V, 15A - 600A	35

Table 6 – 65 KAIC Fuse Sizing

65 KAIC Construction		
Component	Description	Interrupting Rating (kA)
Fuse	Class CC, 600V, 0.5A - 30A	200
Fuse	Class J, 600V, 35A - 600A	200
Disconnect	3P, 600V, 15A - 600A	65

**! CAUTION**

Unit must not be operated without a p-trap. Failure to install a p-trap may result in overflow of condensate water into the unit.

**! CAUTION**

No variable speed compressor shall operate below 50 Hz. Operating variable speed compressors outside the frequency range specified in this manual voids all warranties and may result in compressor failure.

**Condensate Drain Piping**

Unit is equipped with 2 or more condensate drain pan connections. A drain line with p-trap must be installed on every drain connection, with the p-trap not to exceed 15.2 cm (6”) from the drain connection. The lines must be the same pipe size or larger than the drain connection and pitched away from the unit at least 1/8 inch per foot. An air break must be used with long runs of condensate lines.

All drain connections must be used and individually trapped to ensure a minimum amount of condensate accumulation in the drain pans. ABS type cement must be used to join the drain pipe connections.

**Note:** The drain pan connections are 38 mm (1.5”) MPT fitting.

Condensate drain trapping and piping must conform to all applicable governing codes. Drainage of condensate directly onto the roof may be acceptable in certain areas, refer to local codes. If condensate is to drain directly onto the roof a drip pad must be placed below the drain to protect the roof from possible damage.

Draw-through cooling coils will have a negative static pressure in the drain pan area. This will cause an un-trapped drain to back up due to air being pulled up through the condensate drain piping.

Blow-through coils will have a positive static pressure in the drain pan. The condensate piping on these drain pans must be trapped to prevent pressure loss through the drain.

### Draw-Through Coils

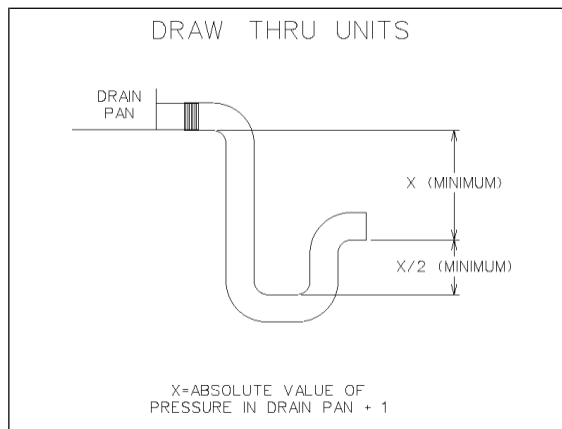

Figure 17 - Draw-Through Drain Trap

The X dimension on the draw-through trap must be at least equal to the absolute value of the negative static pressure in the drain pan plus one inch. To calculate the static pressure at the drain pan add the pressure drops of all components upstream of the drain pan, including the cooling coil, and add the return duct static pressure. Include the dirt allowance pressure drop for the filters to account for the worst-case scenario.

The height from top of the bottom bend of the trap to the bottom of the leaving pipe must be at least equal to one half of the X dimension. This ensures that enough water is stored in the trap to prevent losing the drain seal during unit startup

**Note:** The absolute value of the fan inlet pressure will always be greater than or equal to the absolute value of the static pressure in the drain pan on draw-through units, so the

**! CAUTION**

All condensate drain connection must be used. Drain pans are sloped towards connections.

**! CAUTION**

All condensate drains must be trapped individually before they are connected to a common line.

fan inlet pressure is a safe value to use for the drain pan static pressure.

Table 7 - Draw-Through Drain Trap Dimensions (Metric)

Draw-Through		
Drain Pan Pressure	Trap Dimensions	
Negative Static	X	X/2
(mmHg)	(millimeters)	(millimeters)
-0.93	38.1	19.1
-1.87	50.8	25.4
-2.80	63.5	31.8
-3.74	76.2	38.1
-4.67	88.9	44.5
-5.60	101.6	50.8
-6.54	114.3	57.2
-7.47	127	63.5
-8.41	139.7	69.9
-9.34	152.4	76.2
-10.28	165.1	82.6
-11.21	177.8	88.9
-12.14	190.5	95.3
-13.08	203.2	101.6
-14.01	215.9	108.0
-14.95	228.6	114.3

Table 8 - Draw-Through Drain Trap Dimensions (Imperial)

Draw-Through		
Drain Pan Pressure	Trap Dimensions	
Negative Static (inches of water)	X (inch)	X/2 (inch)
-0.50	1.50	0.75
-1.00	2.00	1.00
-1.50	2.50	1.25
-2.00	3.00	1.50
-2.50	3.50	1.75
-3.00	4.00	2.00
-3.50	4.50	2.25
-4.00	5.00	2.50
-4.50	5.50	2.75
-5.00	6.00	3.00
-5.50	6.50	3.25
-6.00	7.00	3.50
-6.50	7.50	3.75
-7.00	8.00	4.00
-7.50	8.50	4.25
-8.00	9.00	4.50

**Blow-Through Coils**

The Y dimension of blow-through traps must be at least equal to the value of the positive pressure in the drain pan plus one inch. This ensures that there will be enough water stored in the trap to counter the static pressure in the drain pan. To find the pressure subtract any pressure drops between the drain pan and the supply fan from the fan discharge pressure. The worst-case scenario for blow-through coils is the minimum pressure drop, so do not include dirt allowance pressure drops for filters.

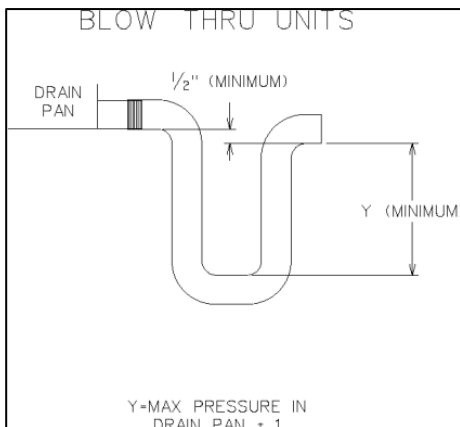

Figure 18 - Blow-Through Drain Trap

The bottom of the leaving pipe must be at least one half inch lower than the bottom of the drain pan connection. This ensures proper drainage when the unit is not running.

**Note:** It may be necessary to fill the trap manually, or the trap can be filled automatically by operating the unit until enough condensate collects to fill the trap. The trap will then be filled when the unit is turned off.

Table 9 - Blow-Through Drain Trap Dimensions (Metric)

Blow-Through	
Drain Pan Pressure	Trap Dimension
Positive Static (mmHg)	Y (millimeters)
0.93	38.1
1.87	50.8
2.80	63.5
3.74	76.2
4.67	88.9
5.60	101.6
6.54	114.3
7.47	127.0
8.41	139.7
9.34	152.4
10.28	165.1
11.21	177.8
12.14	190.5
13.08	203.2
14.01	215.9
14.95	228.6

Table 10 - Blow-Through Drain Trap Dimensions (Imperial)

Blow-Through	
Drain Pan Pressure	Trap Dimension
Positive Static (inches of water)	Y (inch)
0.5	1.5
1.0	2.0
1.5	2.5
2.0	3.0
2.5	3.5
3.0	4.0
3.5	4.5
4.0	5.0
4.5	5.5
5.0	6.0
5.5	6.5
6.0	7.0
6.5	7.5
7.0	8.0
7.5	8.5
8.0	9.0

**Startup** (See back of the manual for startup form)

**! WARNING**  
 Improper installation, adjustment, alteration, service or maintenance can cause property damage, personal injury or loss of life. Startup and service must be performed by a Factory Trained Service Technician.

**! WARNING**  
 Electric shock hazard. Shut off all electrical power to the unit to avoid shock hazard or injury from rotating parts.

During startup, it is necessary to perform routine checks on the performance of the unit. This includes checking the air flow, air filters, condenser water flow, dampers, heaters, and refrigerant charge.

**Filters**

Do not operate the unit without filters in place. Unit must be checked for correct filter placement during startup. Operation of the equipment

without filters will result in clogged cooling and heating coils.

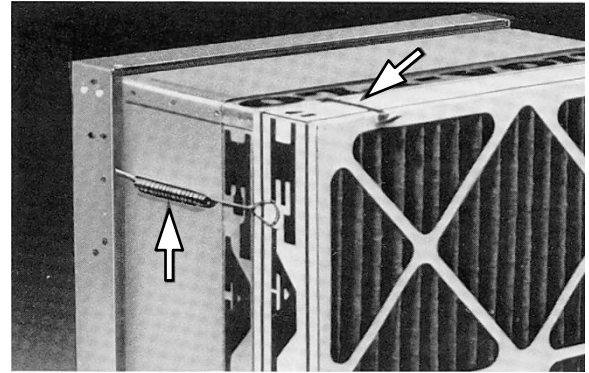

Figure 19 - Top Clip and Side Spring Fastener Securing Filters in Place

**! CAUTION**  
 Before completing startup and leaving the unit a complete operating cycle must be observed to verify that all components are functioning properly.

*Cartridge Filter Installation*

Cartridge filters may be held in their proper orientation and placement with channels, spring fasteners, or clips (see Figure 19).

*HEPA Filters*

HEPA filters can be selected in the Pre, Standard, and Final filter position. HEPA filters are a highly effective filter. HEPA filters require field certification.

HEPA filters can be installed in the same way as cartridge filters. Place the filter on the holding frame and then hold the filter in place by the swing bolt assembly on the sides. If the unit includes HEPA pre-filters, an adapter frame is included. The adapter frame holds the HEPA filters and the swing bolts attach to the adapter frame.

*Metal Mesh Filters*

Metal mesh filters are washable expanded aluminum mesh filters that are mounted over the outside air intake. These filters are normally located on the outside air hood. These filters are commonly used to prevent moisture carryover from the outside. An access panel is provided to slide out the filters for cleaning.

### **Airflow Balancing and Checking**

High performance systems commonly have complex air distribution and fan systems. Unqualified personnel must not attempt to adjust fan operation, or air circulation, as all systems have unique operations characteristics. Professional air balance specialists must be employed to establish actual operating conditions, and to configure the air delivery system for optimal performance.

### **Air Flow Monitoring**

Some units include an air flow monitoring device. Air flow can be measured either at the outside air opening, supply fans and/or return fans. Outside air uses a measuring grid and the fans use a piezo ring on their inlets to collect this information. A singular processor located in the vestibule handles all of these different readings.

### **Supply, Return, and Exhaust Backward Curved Fans**

RZ Series units are equipped with direct drive backward curved fan assemblies that are selected to deliver the air volume specified according to unit size and job requirements. This is either done with air volume bands in the blower wheels or with VFDs. Field airflow adjustment may be required at startup.

Air volume bands for the wheels are sized according to the unit's air delivery specifications and can also be ordered from the factory for field installation. Wheels come standard with a 10% air volume band, as a safety factor, in case additional air volume is required from the unit.

### *Airflow Adjustment*

If reduced air volume is required an air volume band or larger air volume band can be installed within the blower wheel to

reduce the amount of air delivered by the wheel.

If the unit is factory equipped with the air volume band and additional air volume is required, the band can be removed from the wheel.

Use fan program in AAONEcat32™ to determine the new band size for the required CFM and static pressure.

The following photos of a wheel are provided for practical guidelines only in order to identify the air band location in the wheel. Actual field installation of the air band into the wheel will require access into and through the blower wheel venture, which may require removal of the fan motor and wheel.

Air volume bands are made of aluminum, sized and equipped with easy bend tabs that are to be inserted into pre-punched slots provided on the wheel. Once the band has been inserted into the slots, it **MUST BE** secured by bending the tabs over from the back side of the wheel and also **MUST BE** secured from the inside by connecting the ends together with a pop-rivet in the holes provided on the ends of the band.

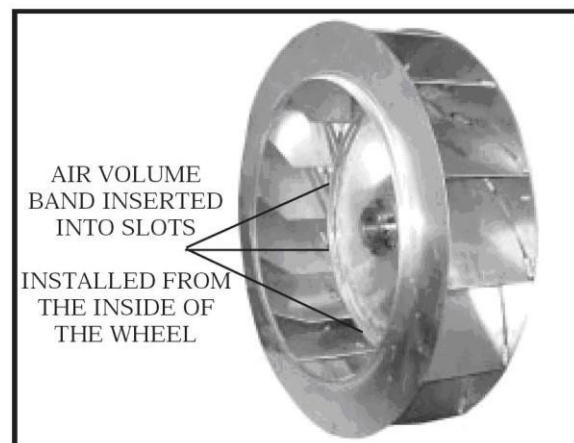

Figure 20 - Air Volume Band



If the band is field installed, a hand held poprivet tool is recommended for connecting the band ends together. Caution must be taken to assure that the band is tightly installed and no damage, denting or alteration to the wheel or blades occurs during the installation.

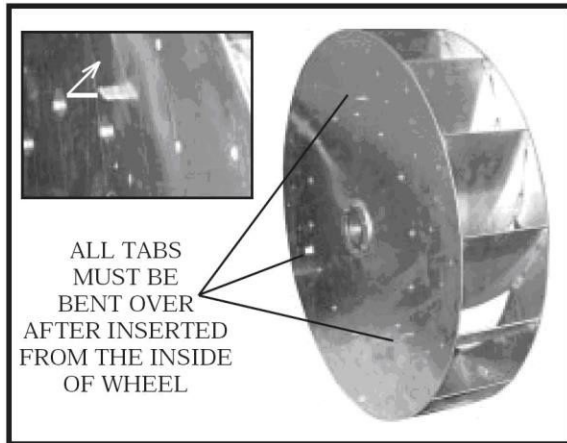

Figure 21 - Air Volume Band Tab Locations

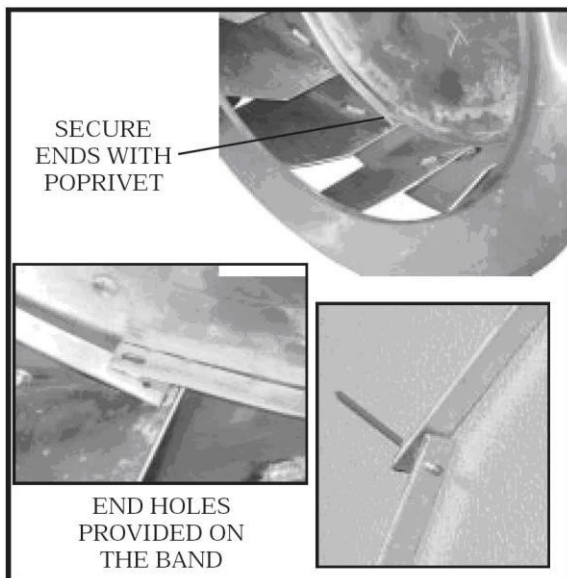

Figure 22 - Securing Air Volume Band Ends

For single set screw applications, tighten the set screw to the required torque setting (Table 11 using a calibrated torque wrench. For double set screw applications, tighten one set screw to half of the required torque setting (Table 11) using a calibrated torque wrench. Tighten the second set screw to the full

required torque setting then tighten the first set screw to the full required torque setting.

Table 11 - Plenum Fan Set Screw Specifications

SET SCREW DIAMETER	TORQUE (Nm [IN-LBS])
6.4 mm (1/4")	9 [80]
7.9 mm (5/16")	14.2 [126]
9.5 mm (3/8")	27.12 [240]
11.1 mm (7/16")	43.4 [384]
12.7 mm (1/2")	84.1 [744]
14.3 mm (9/16")	122 [1,080]
15.9 mm (5/8")	169.5 [1,500]
19.1 mm (3/4")	291.5 [2,580]
22.2 mm (7/8")	406.8 [3,600]
25.4 mm (1")	610.2 [5,400]

The gap tolerances that are allowed between the blower and the inlet cone for the RZ plenum fan blowers are shown in *Note*: 1/4" = 6.35 mm, 1/8" = 3.18 mm

Figure 23. The inlet cone can be moved as necessary to center the cone in relation to the blower. The blower can be moved on the motor shaft to set the correct overlap. These tolerances are critical to the performance of the blower.

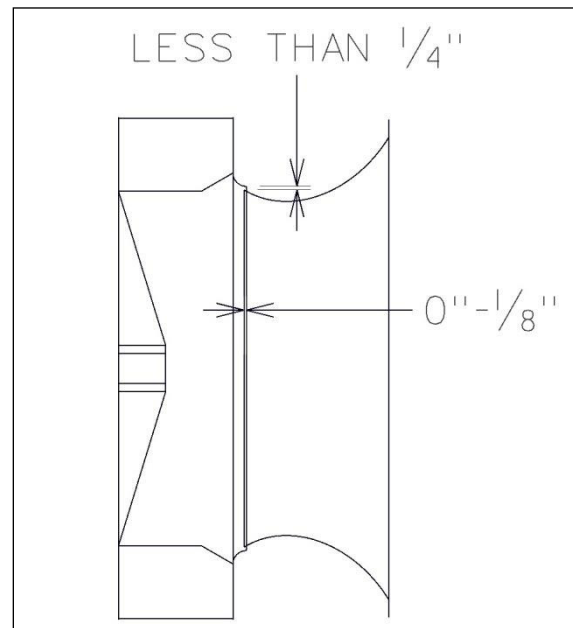

Note: 1/4" = 6.35 mm, 1/8" = 3.18 mm

Figure 23 - Plenum Fan Gap Tolerances

### Back Draft Damper Setup

The counter balance is shipped loose and may need to be installed during start-up on some applications. Not all applications will require the use of the counter balance on the back draft dampers. If the unit is equipped with back draft dampers on the supply fan, start the fans without the counter balance and observe the operation of the back draft dampers. If the back draft dampers do not open completely, then the counter balance can be installed to assist with the opening of the back draft dampers. Install the counter balance in the horizontal position when the back draft dampers are held closed (see *Figure 24*).

The back draft damper will remain open with no back pressure on the damper. The damper will close completely when back pressure is applied.



Figure 24 - Closed Back Draft Damper



Figure 25 - Open Back Draft Damper

### Adjusting Refrigerant Charge

Adjusting the charge of a system in the field must be based on determination of liquid sub-cooling and evaporator superheat. On a system with a TXV liquid sub-cooling is more representative of the charge than evaporator superheat but both measurements must be taken.

#### **! WARNING**

Do not use torch or other potential ignition source to detect refrigerant leaks. Use only electronic detector suitable for the refrigerant, or bubble method with chlorine free detergent.

#### **! CAUTION**

The Clean Air Act of 1990 bans the intentional venting of refrigerant (CFC's and HCFC's) as of July 1, 1992. Approved methods of recovery, recycling or reclaiming must be followed. Fines and/or incarceration may be levied for non-compliance.

#### **! WARNING**

Ensure that there are no live electrical components or wiring exposed when adjusting charge, recovering charge, or purging the system. Ensure that earthing continuity is unbroken.

#### *Before Charging*

Unit being charged must be at or near full load conditions before adjusting the charge.

Units equipped with hot gas reheat must be charged with the hot gas reheat valves closed while the unit is in cooling mode to get the proper charge. After charging, operate unit in

reheat (dehumidification) mode to check for correct operation.

Units equipped with heat pump options must be charged in heating mode to get the proper charge. After charging, unit must be operated in cooling mode to check for correct charge. Charge may need to be adjusted for cooling mode. If adjustments are made in the cooling mode heating mode must be rerun to verify proper operation.

After adding or removing charge the system must be allowed to stabilize, typically 10-15 minutes, before making any other adjustments.

The type of unit and options determine the ranges for liquid sub-cooling and evaporator superheat. Refer to Table 12 and Table 13 when determining the proper sub-cooling.

#### *Checking Liquid Sub-Cooling*

Measure the temperature of the liquid line as it leaves the condenser coil.

Read the gauge pressure at the liquid line close to the point where the temperature was taken. You must use liquid line pressure as it will vary from discharge pressure due to condenser coil pressure drop.

Convert the pressure obtained to a saturated temperature using the appropriate refrigerant temperature-pressure chart.

Subtract the measured liquid line temperature from the saturated temperature to determine the liquid sub-cooling.

Compare calculated sub-cooling to the Table 12 and Table 13 for the appropriate unit type and options.

#### *Checking Evaporator Superheat*

Measure the temperature of the suction line close to the compressor.

Read gauge pressure at the suction line close to the compressor.

Convert the pressure obtained to a saturated temperature using the appropriate refrigerant temperature-pressure chart.

Subtract the saturated temperature from the measured suction line temperature to determine the evaporator superheat.

For refrigeration systems with tandem compressors, it is critical that the suction superheat setpoint on the TXV is set with one compressor running. The suction superheat must be 5.6-7.2°C (10-13°F) with one compressor running. The suction superheat will increase with both compressors in a tandem running. Inadequate suction superheat can allow liquid refrigerant to return to the compressors which will wash the oil out of the compressor. Lack of oil lubrication will destroy a compressor. Liquid subcooling must be measured with both compressors in a refrigeration system running.

Compare calculated superheat to the Table 12 and Table 13 for the appropriate unit type and options.

### CAUTION

Expansion valve must be adjusted to approximately 4.4-8.3°C (8-15°F) of suction superheat. Failure to have sufficient superheat will damage the compressor and void the warranty.

Table 12 - Acceptable Fin & Tube Sub-Cooling and Superheat Temperatures

<b>Air-Cooled Condenser (Metric)</b>		<b>Air-Cooled Condenser (Imperial)</b>	
Sub-Cooling <sup>2</sup>	4.4-8.3°C / 1.1-2.2°C (HP)*	Sub-Cooling <sup>2</sup>	8-15°F / 2-4°F (HP)*
Sub-Cooling with Hot Gas Reheat <sup>2</sup>	4.4-8.3°C / 1.1-3.3°C (HP)*	Sub-Cooling with Hot Gas Reheat <sup>2</sup>	8-15°F / 2-6°F (HP)*
Superheat <sup>1</sup>	4.4-8.3°C	Superheat <sup>1</sup>	8-15°F
<b>Evaporative Condenser</b>		<b>Evaporative Condenser</b>	
Sub-Cooling <sup>2</sup>	3.3-5.5°C	Sub-Cooling <sup>2</sup>	6-10°F
Sub-Cooling with Hot Gas Reheat <sup>2</sup>	4.4-6.7°C	Sub-Cooling with Hot Gas Reheat <sup>2</sup>	8-12°F
Superheat <sup>1</sup>	5.6-8.3°C	Superheat <sup>1</sup>	10-15°F
<b>Water-Cooled Condenser/ Water Source Heat Pump in Cooling Mode</b>		<b>Water-Cooled Condenser/ Water Source Heat Pump in Cooling Mode</b>	
Sub-Cooling <sup>2</sup>	2.2-4.4°C	Sub-Cooling <sup>2</sup>	4-8°F
Sub-Cooling with Hot Gas Reheat <sup>2</sup>	4.4-6.7°C	Sub-Cooling with Hot Gas Reheat <sup>2</sup>	8-12°F
Superheat <sup>1</sup>	4.4-8.3°C	Superheat <sup>1</sup>	8-15°F

<sup>1</sup> One compressor running in tandem  
<sup>2</sup> Two compressors running in tandem

Table 13 - Acceptable Microchannel Air-Cooled Condenser Coil Liquid Sub Cooling Values (Metric)

Ambient (°C)	Cooling Mode Liquid Sub-Cooling Values(°C)				
	Evaporator Coil Saturation Temperature (°C)				
	4.4	7.2	8.9	10.0	12.8
19.4	5.0 - 7.8	4.4 - 7.2	4.4 - 7.2	3.9 - 6.7	2.8 - 5.6
22.2	5.6 - 8.3	5.0 - 7.8	5.0 - 7.8	4.4 - 7.2	3.9 - 6.7
27.8	5.6 - 8.3	5.6 - 8.3	5.6 - 8.3	5.0 - 7.8	3.9 - 6.7
35.0	5.6 - 8.3	5.6 - 8.3	5.6 - 8.3	5.0 - 7.8	4.4 - 7.2
40.6	6.1 - 8.9	6.1 - 8.9	5.6 - 8.3	5.6 - 8.3	4.4 - 7.2
46.1	5.6 - 8.3	6.1 - 8.9	6.1 - 8.9	6.1 - 8.9	5.0 - 7.8

Table 14 - Acceptable Microchannel Air-Cooled Condenser Coil  
Liquid Sub-Cooling Values (Imperial)

Ambient (°F)	Cooling Mode Liquid Sub-Cooling Values(°F)				
	Evaporator Coil Saturation Temperature (°F)				
	40	45	48	50	55
67	9 - 14	8 - 13	8 - 13	7 - 12	5 - 10
72	10 - 15	9 - 14	9 - 14	8 - 13	7 - 12
82	10 - 15	10 - 15	10 - 15	9 - 14	7 - 12
95	10 - 15	10 - 15	10 - 15	9 - 14	8 - 13
105	11 - 16	11 - 16	10 - 15	10 - 15	8 - 13
115	10 - 15	11 - 16	11 - 16	11 - 16	9 - 14

Notes:

1. Microchannel condenser coils are more sensitive to charge. The system must be running in cooling mode with compressor, supply airflow & condenser fan speed at full load. The sub-cooling value changes depending on the ambient temperature reading and the evaporator coil saturation temperature. To find the correct sub-cooling value, find the ambient temperature on the first column and follow that across to the SST (4.4-12.8°C [40-55°F]).
2. Superheat for Microchannel condenser coils must be between 4.4 and 8.3°C (8 - 15°F)

### Adjusting Sub-cooling and Superheat Temperatures

The system is overcharged if the sub-cooling temperature is too high and the evaporator is fully loaded (low loads on the evaporator result in increased sub-cooling) and the evaporator superheat is within the temperature range as shown in the Table 12 and Table 13 (high superheat results in increased sub-cooling).

Correct an overcharged system by reducing the amount of refrigerant in the system to lower the sub-cooling.

 **CAUTION**

**DO NOT OVERCHARGE!**

Refrigerant overcharging will result in elevated compressor discharge pressure. Maximum allowable charge of any single circuit is 133 kg (4700 oz).

The system is undercharged if the superheat is too high and the sub-cooling is too low.

Correct an undercharged system by adding refrigerant to the system to reduce superheat and raise sub-cooling.

If the sub-cooling is correct and the superheat is too high, the expansion valve may need adjustment to correct the superheat.

### **Freeze Stat Startup**

Freeze Stat is an adjustable temperature sensor (-23.3°C to 21.1°C [-10 to 70°F]) mounted on the tubing of the first cooling circuit and wired to de-energize all cooling circuits if tubing temperature falls below setpoint. Option is used to prevent freezing of evaporator coil.

Recommended Setting: 0°C to 1.7°C (32° F to 35° F)

Table 15 – Minimum Airflow and Room Areas

Charge in kg (oz)	Min Airflow in m <sup>3</sup> /h (CFM)	Minimum Room Area in m <sup>2</sup> (ft <sup>2</sup> )			
		1.8 m (6 ft) release height	2.2 m (7.2 ft) release height	3 m (10 ft) release height	3.7 m (12 ft) release height
28.3 (1000)	7646 (4500)*	106 (1145)	87 (937)	64 (687)	52 (557)
29.8 (1050)	7646 (4500)*	112 (1203)	91 (904)	67 (722)	54 (585)
31.2 (1100)	7646 (4500)*	117 (1260)	96 (1031)	70 (756)	57 (613)
32.6 (1150)	7646 (4500)*	122 (1317)	100 (1078)	73 (790)	60 (641)
34.0 (1200)	7646 (4500)*	128 (1375)	104 (1125)	77 (825)	62 (669)
35.4 (1250)	7646 (4500)*	133 (1432)	109 (1171)	80 (859)	65 (697)
36.9 (1300)	7646 (4500)*	138 (1489)	113 (1218)	83 (893)	67 (724)
38.3 (1350)	7646 (4500)*	144 (1546)	118 (1265)	86 (928)	70 (752)
39.7 (1400)	7646 (4500)*	149 (1604)	122 (1312)	89 (962)	72 (780)
41.1 (1450)	7646 (4500)*	154 (1661)	126 (1359)	93 (997)	75 (808)
42.5 (1500)	7646 (4500)*	160 (1718)	131 (1406)	96 (1031)	78 (836)
43.9 (1550)	7646 (4500)*	165 (1775)	135 (1453)	99 (1065)	80 (864)
45.4 (1600)	7646 (4500)*	170 (1833)	139 (1500)	102 (1100)	83 (892)
46.8 (1650)	7646 (4500)*	176 (1890)	144 (1546)	105 (1134)	85 (919)
48.2 (1700)	7646 (4500)*	181 (1947)	148 (1593)	109 (1168)	88 (947)
49.6 (1750)	7646 (4500)*	186 (2005)	152 (1640)	112 (1203)	91 (975)
51.0 (1800)	7646 (4500)*	192 (2062)	157 (1687)	115 (1237)	93 (1003)
52.4 (1850)	7646 (4500)*	197 (2119)	161 (1734)	118 (1271)	96 (1031)
53.9 (1900)	7646 (4500)*	202 (2176)	165 (1781)	121 (1306)	98 (1059)
55.3 (1950)	7646 (4500)*	208 (2234)	170 (1828)	125 (1340)	101 (1087)
56.7 (2000)	7646 (4500)*	213 (2291)	174 (1874)	128 (1375)	104 (1115)
58.1 (2050)	7646 (4500)*	218 (2348)	178 (1921)	131 (1409)	106 (1142)
59.5 (2100)	7646 (4500)*	223 (2405)	183 (1968)	134 (1443)	109 (1170)
61.0 (2150)	7646 (4500)*	229 (2463)	187 (2015)	137 (1478)	111 (1198)
62.4 (2200)	7646 (4500)*	234 (2520)	192 (2062)	140 (1512)	114 (1226)
63.8 (2250)	7646 (4500)*	239 (2577)	196 (2109)	144 (1546)	116 (1254)
65.2 (2300)	7646 (4500)*	245 (2635)	200 (2156)	147 (1581)	119 (1282)
66.6 (2350)	7646 (4500)*	250 (2692)	205 (2202)	150 (1615)	122 (1310)
68.0 (2400)	7646 (4500)*	255 (2749)	209 (2249)	153 (1649)	124 (1337)
69.5 (2450)	7646 (4500)*	261 (2806)	213 (2296)	156 (1684)	127 (1365)
70.9 (2500)	7646 (4500)*	266 (2864)	218 (2343)	160 (1718)	129 (1393)
72.3 (2550)	7646 (4500)*	271 (2921)	222 (2390)	163 (1753)	132 (1421)
73.7 (2600)	7646 (4500)*	277 (2978)	226 (2437)	166 (1787)	135 (1449)
75.1 (2650)	7646 (4500)*	282 (3035)	231 (2484)	169 (1821)	137 (1477)
76.5 (2700)	7758 (4566)**	287 (3093)	235 (2530)	172 (1856)	140 (1505)

Table 16 – Minimum Airflow and Room Areas (continued)

Charge of Largest Circuit in kg (oz)	Min Airflow in m <sup>3</sup> /h (CFM)	Minimum Room Area in m <sup>2</sup> (ft <sup>2</sup> )			
		1.8 m (6 ft) release height	2.2 m (7.2 ft) release height	3 m (10 ft) release height	3.7 m (12 ft) release height
78.0 (2750)	7901 (4651)**	293 (3150)	239 (2577)	176 (1890)	142 (1532)
79.4 (2800)	8045 (4735)**	298 (3207)	244 (2624)	179 (1924)	145 (1560)
80.8 (2850)	8189 (4820)**	303 (3265)	248 (2671)	182 (1959)	148 (1588)
82.2 (2900)	8332 (4904)**	309 (3322)	252 (2718)	185 (1993)	150 (1616)
83.6 (2950)	8476 (4989)**	314 (3379)	257 (2765)	188 (2027)	153 (1644)
85.0 (3000)	8620 (5073)**	319 (3436)	261 (2812)	192 (2062)	155 (1672)
86.5 (3050)	8763 (5158)**	325 (3494)	266 (2858)	195 (2096)	158 (1700)
87.9 (3100)	8907 (5243)**	330 (3551)	270 (2905)	198 (2131)	160 (1727)
89.3 (3150)	9051 (5327)**	335 (3608)	274 (2952)	201 (2165)	163 (1755)
90.7 (3200)	9194 (5412)**	341 (3665)	279 (2999)	204 (2199)	166 (1783)
92.1 (3250)	9338 (5496)**	346 (3723)	283 (3046)	208 (2234)	168 (1811)
93.6 (3300)	9482 (5581)**	351 (3780)	287 (3093)	211 (2268)	171 (1839)
95.0 (3350)	9625 (5665)	356 (3837)	292 (3140)	214 (2302)	173 (1867)
96.4 (3400)	9769 (5750)	362 (3895)	296 (3186)	217 (2337)	176 (1895)
97.8 (3450)	9913 (5834)	367 (3952)	300 (3233)	220 (2371)	179 (1923)
99.2 (3500)	10056 (5919)	372 (4009)	305 (3280)	223 (2405)	181 (1950)
100.6 (3550)	10200 (6004)	378 (4066)	309 (3327)	227 (2440)	184 (1978)
102.1 (3600)	10344 (6088)	383 (4124)	313 (3374)	230 (2474)	186 (2006)
103.5 (3650)	10487 (6173)	388 (4181)	318 (3421)	233 (2509)	189 (2034)
104.9 (3700)	10631 (6257)	394 (4238)	322 (3468)	236 (2543)	192 (2062)
106.3 (3750)	10775 (6342)	399 (4295)	327 (3514)	239 (2577)	194 (2090)
107.7 (3800)	10918 (6426)	404 (4353)	331 (3561)	243 (2612)	197 (2118)
109.1 (3850)	11062 (6511)	410 (4410)	335 (3608)	246 (2646)	199 (2145)
110.6 (3900)	11206 (6595)	415 (4467)	340 (3655)	249 (2680)	202 (2173)
112.0 (3950)	11349 (6680)	420 (4525)	344 (3702)	252 (2715)	204 (2201)
113.4 (4000)	11493 (6765)	426 (4582)	348 (3749)	255 (2749)	207 (2229)
116.2 (4100)	11780 (6934)	436 (4696)	357 (3843)	262 (2818)	212 (2285)
119.1 (4200)	12068 (7103)	447 (4811)	366 (3936)	268 (2887)	217 (2340)
121.9 (4300)	12355 (7272)	458 (4925)	374 (4030)	275 (2955)	223 (2396)
124.7 (4400)	12642 (7441)	468 (5040)	383 (4124)	281 (3024)	228 (2452)
127.6 (4500)	12930 (7610)	479 (5155)	392 (4217)	287 (3093)	233 (2508)
130.4 (4600)	13217 (7779)	490 (5269)	401 (4311)	294 (3161)	238 (2563)
133.2 (4700)	13504 (7948)	500 (5384)	409 (4405)	300 (3230)	243 (2619)

\*Minimum airflow for RZ product

\*\* Minimum airflow for units equipped with gas or electric heat is 9550 CFM.

Table 17 M - R-410A Refrigerant Temperature-Pressure Chart (Metric)

°C	KPA	°C	KPA	°C	KPA	°C	KPA	°C	KPA
<b>-6.7</b>	539.9	<b>8.3</b>	928.8	<b>23.3</b>	1473.5	<b>38.3</b>	2213.3	<b>53.3</b>	3193.8
<b>-6.1</b>	551.6	<b>8.9</b>	946.0	<b>23.9</b>	1496.9	<b>38.9</b>	2245.0	<b>53.9</b>	3235.8
<b>-5.6</b>	564.0	<b>9.4</b>	963.2	<b>24.4</b>	1521.0	<b>39.4</b>	2276.7	<b>54.4</b>	3277.9
<b>-5.0</b>	576.4	<b>10.0</b>	980.5	<b>25.0</b>	1545.2	<b>40.0</b>	2309.1	<b>55.0</b>	3320.6
<b>-4.4</b>	588.8	<b>10.6</b>	998.4	<b>25.6</b>	1570.0	<b>40.6</b>	2341.5	<b>55.6</b>	3363.4
<b>-3.9</b>	601.2	<b>11.1</b>	1016.3	<b>26.1</b>	1594.8	<b>41.1</b>	2374.6	<b>56.1</b>	3406.8
<b>-3.3</b>	614.3	<b>11.7</b>	1034.9	<b>26.7</b>	1619.6	<b>41.7</b>	2408.4	<b>56.7</b>	3450.9
<b>-2.8</b>	627.4	<b>12.2</b>	1053.6	<b>27.2</b>	1645.1	<b>42.2</b>	2442.2	<b>57.2</b>	3495.1
<b>-2.2</b>	640.5	<b>12.8</b>	1072.2	<b>27.8</b>	1670.7	<b>42.8</b>	2476.0	<b>57.8</b>	3539.9
<b>-1.7</b>	654.3	<b>13.3</b>	1090.8	<b>28.3</b>	1696.2	<b>43.3</b>	2510.5	<b>58.3</b>	3585.4
<b>-1.1</b>	667.4	<b>13.9</b>	1110.1	<b>28.9</b>	1722.4	<b>43.9</b>	2544.9	<b>58.9</b>	3630.9
<b>-0.6</b>	681.2	<b>14.4</b>	1129.4	<b>29.4</b>	1749.3	<b>44.4</b>	2580.1	<b>59.4</b>	3677.1
<b>0.0</b>	695.7	<b>15.0</b>	1149.4	<b>30.0</b>	1775.5	<b>45.0</b>	2616.0	<b>60.0</b>	3724.0
<b>0.6</b>	709.5	<b>15.6</b>	1169.4	<b>30.6</b>	1802.4	<b>45.6</b>	2651.8	<b>60.6</b>	3771.6
<b>1.1</b>	724.0	<b>16.1</b>	1189.4	<b>31.1</b>	1829.9	<b>46.1</b>	2688.4	<b>61.1</b>	3819.1
<b>1.7</b>	738.5	<b>16.7</b>	1209.4	<b>31.7</b>	1857.5	<b>46.7</b>	2724.9	<b>61.7</b>	3867.4
<b>2.2</b>	752.9	<b>17.2</b>	1230.1	<b>32.2</b>	1885.8	<b>47.2</b>	2761.4	<b>62.2</b>	3915.7
<b>2.8</b>	768.1	<b>17.8</b>	1251.4	<b>32.8</b>	1914.1	<b>47.8</b>	2798.7	<b>62.8</b>	3965.3
<b>3.3</b>	783.3	<b>18.3</b>	1272.1	<b>33.3</b>	1942.3	<b>48.3</b>	2836.6	<b>63.3</b>	4015.0
<b>3.9</b>	798.4	<b>18.9</b>	1293.5	<b>33.9</b>	1971.3	<b>48.9</b>	2874.5	<b>63.9</b>	4065.3
<b>4.4</b>	814.3	<b>19.4</b>	1314.9	<b>34.4</b>	2000.2	<b>49.4</b>	2913.1	<b>64.4</b>	4115.6
<b>5.0</b>	829.5	<b>20.0</b>	1336.9	<b>35.0</b>	2029.9	<b>50.0</b>	2952.4	<b>65.0</b>	4167.3
<b>5.6</b>	846.0	<b>20.6</b>	1359.0	<b>35.6</b>	2059.5	<b>50.6</b>	2991.7	<b>65.6</b>	4219.1
<b>6.1</b>	861.9	<b>21.1</b>	1381.8	<b>36.1</b>	2089.2	<b>51.1</b>	3031.0		
<b>6.7</b>	878.4	<b>21.7</b>	1403.8	<b>36.7</b>	2120.2	<b>51.7</b>	3071.0		
<b>7.2</b>	895.0	<b>22.2</b>	1427.3	<b>37.2</b>	2150.6	<b>52.2</b>	3111.7		
<b>7.8</b>	911.5	<b>22.8</b>	1450.0	<b>37.8</b>	2181.6	<b>52.8</b>	3153.1		



Table 18 - R-410A Refrigerant Temperature-Pressure Chart (Imperial)

°F	PSIG	°F	PSIG	°F	PSIG	°F	PSIG	°F	PSIG
<b>20</b>	78.3	<b>47</b>	134.7	<b>74</b>	213.7	<b>101</b>	321.0	<b>128</b>	463.2
<b>21</b>	80.0	<b>48</b>	137.2	<b>75</b>	217.1	<b>102</b>	325.6	<b>129</b>	469.3
<b>22</b>	81.8	<b>49</b>	139.7	<b>76</b>	220.6	<b>103</b>	330.2	<b>130</b>	475.4
<b>23</b>	83.6	<b>50</b>	142.2	<b>77</b>	224.1	<b>104</b>	334.9	<b>131</b>	481.6
<b>24</b>	85.4	<b>51</b>	144.8	<b>78</b>	227.7	<b>105</b>	339.6	<b>132</b>	487.8
<b>25</b>	87.2	<b>52</b>	147.4	<b>79</b>	231.3	<b>106</b>	344.4	<b>133</b>	494.1
<b>26</b>	89.1	<b>53</b>	150.1	<b>80</b>	234.9	<b>107</b>	349.3	<b>134</b>	500.5
<b>27</b>	91.0	<b>54</b>	152.8	<b>81</b>	238.6	<b>108</b>	354.2	<b>135</b>	506.9
<b>28</b>	92.9	<b>55</b>	155.5	<b>82</b>	242.3	<b>109</b>	359.1	<b>136</b>	513.4
<b>29</b>	94.9	<b>56</b>	158.2	<b>83</b>	246.0	<b>110</b>	364.1	<b>137</b>	520.0
<b>30</b>	96.8	<b>57</b>	161.0	<b>84</b>	249.8	<b>111</b>	369.1	<b>138</b>	526.6
<b>31</b>	98.8	<b>58</b>	163.8	<b>85</b>	253.7	<b>112</b>	374.2	<b>139</b>	533.3
<b>32</b>	100.9	<b>59</b>	166.7	<b>86</b>	257.5	<b>113</b>	379.4	<b>140</b>	540.1
<b>33</b>	102.9	<b>60</b>	169.6	<b>87</b>	261.4	<b>114</b>	384.6	<b>141</b>	547.0
<b>34</b>	105.0	<b>61</b>	172.5	<b>88</b>	265.4	<b>115</b>	389.9	<b>142</b>	553.9
<b>35</b>	107.1	<b>62</b>	175.4	<b>89</b>	269.4	<b>116</b>	395.2	<b>143</b>	560.9
<b>36</b>	109.2	<b>63</b>	178.4	<b>90</b>	273.5	<b>117</b>	400.5	<b>144</b>	567.9
<b>37</b>	111.4	<b>64</b>	181.5	<b>91</b>	277.6	<b>118</b>	405.9	<b>145</b>	575.1
<b>38</b>	113.6	<b>65</b>	184.5	<b>92</b>	281.7	<b>119</b>	411.4	<b>146</b>	582.3
<b>39</b>	115.8	<b>66</b>	187.6	<b>93</b>	285.9	<b>120</b>	416.9	<b>147</b>	589.6
<b>40</b>	118.1	<b>67</b>	190.7	<b>94</b>	290.1	<b>121</b>	422.5	<b>148</b>	596.9
<b>41</b>	120.3	<b>68</b>	193.9	<b>95</b>	294.4	<b>122</b>	428.2	<b>149</b>	604.4
<b>42</b>	122.7	<b>69</b>	197.1	<b>96</b>	298.7	<b>123</b>	433.9	<b>150</b>	611.9
<b>43</b>	125.0	<b>70</b>	200.4	<b>97</b>	303.0	<b>124</b>	439.6		
<b>44</b>	127.4	<b>71</b>	203.6	<b>98</b>	307.5	<b>125</b>	445.4		
<b>45</b>	129.8	<b>72</b>	207.0	<b>99</b>	311.9	<b>126</b>	451.3		
<b>46</b>	132.2	<b>73</b>	210.3	<b>100</b>	316.4	<b>127</b>	457.3		

Table 19 - R-454B Refrigerant Temperature-Pressure Chart (Metric)

°C	KPA	°C	KPA	°C	KPA	°C	KPA	°C	KPA
<b>-6.7</b>	484.5	<b>8.3</b>	843.3	<b>23.3</b>	1348.0	<b>38.3</b>	2034.6	<b>53.3</b>	2946.9
<b>-6.1</b>	495.6	<b>8.9</b>	859.3	<b>23.9</b>	1370.0	<b>38.9</b>	2064.1	<b>53.9</b>	2985.7
<b>-5.6</b>	506.9	<b>9.4</b>	875.3	<b>24.4</b>	1392.2	<b>39.4</b>	2093.9	<b>54.4</b>	3024.9
<b>-5.0</b>	518.2	<b>10.0</b>	891.6	<b>25.0</b>	1414.6	<b>40.0</b>	2123.9	<b>55.0</b>	3064.5
<b>-4.4</b>	529.7	<b>10.6</b>	908.1	<b>25.6</b>	1437.3	<b>40.6</b>	2154.3	<b>55.6</b>	3104.5
<b>-3.9</b>	541.5	<b>11.1</b>	924.8	<b>26.1</b>	1460.3	<b>41.1</b>	2185.0	<b>56.1</b>	3144.9
<b>-3.3</b>	553.3	<b>11.7</b>	941.7	<b>26.7</b>	1483.5	<b>41.7</b>	2216.1	<b>56.7</b>	3185.8
<b>-2.8</b>	565.4	<b>12.2</b>	958.8	<b>27.2</b>	1507.0	<b>42.2</b>	2247.4	<b>57.2</b>	3227.0
<b>-2.2</b>	577.6	<b>12.8</b>	976.2	<b>27.8</b>	1530.8	<b>42.8</b>	2279.1	<b>57.8</b>	3268.6
<b>-1.7</b>	589.9	<b>13.3</b>	993.7	<b>28.3</b>	1554.8	<b>43.3</b>	2311.1	<b>58.3</b>	3310.7
<b>-1.1</b>	602.5	<b>13.9</b>	1011.5	<b>28.9</b>	1579.0	<b>43.9</b>	2343.5	<b>58.9</b>	3353.2
<b>-0.6</b>	615.2	<b>14.4</b>	1029.4	<b>29.4</b>	1603.6	<b>44.4</b>	2376.2	<b>59.4</b>	3396.1
<b>0.0</b>	628.1	<b>15.0</b>	1047.6	<b>30.0</b>	1628.4	<b>45.0</b>	2409.2	<b>60.0</b>	3439.5
<b>0.6</b>	641.2	<b>15.6</b>	1066.0	<b>30.6</b>	1653.5	<b>45.6</b>	2442.6	<b>60.6</b>	3483.3
<b>1.1</b>	654.4	<b>16.1</b>	1084.7	<b>31.1</b>	1678.8	<b>46.1</b>	2476.2	<b>61.1</b>	3527.6
<b>1.7</b>	667.8	<b>16.7</b>	1103.5	<b>31.7</b>	1704.4	<b>46.7</b>	2510.3	<b>61.7</b>	3572.3
<b>2.2</b>	681.4	<b>17.2</b>	1122.6	<b>32.2</b>	1730.4	<b>47.2</b>	2544.7	<b>62.2</b>	3617.4
<b>2.8</b>	695.2	<b>17.8</b>	1141.9	<b>32.8</b>	1756.6	<b>47.8</b>	2579.4	<b>62.8</b>	3663.0
<b>3.3</b>	709.2	<b>18.3</b>	1161.5	<b>33.3</b>	1783.0	<b>48.3</b>	2614.5	<b>63.3</b>	3709.2
<b>3.9</b>	723.3	<b>18.9</b>	1181.3	<b>33.9</b>	1809.9	<b>48.9</b>	2650.0	<b>63.9</b>	3755.7
<b>4.4</b>	737.6	<b>19.4</b>	1201.3	<b>34.4</b>	1836.9	<b>49.4</b>	2685.7	<b>64.4</b>	3802.7
<b>5.0</b>	752.2	<b>20.0</b>	1221.5	<b>35.0</b>	1864.3	<b>50.0</b>	2721.9	<b>65.0</b>	3850.3
<b>5.6</b>	766.9	<b>20.6</b>	1242.0	<b>35.6</b>	1891.9	<b>50.6</b>	2758.5	<b>65.6</b>	3898.4
<b>6.1</b>	781.8	<b>21.1</b>	1262.8	<b>36.1</b>	1919.8	<b>51.1</b>	2795.4		
<b>6.7</b>	796.9	<b>21.7</b>	1283.7	<b>36.7</b>	1948.1	<b>51.7</b>	2832.7		
<b>7.2</b>	812.2	<b>22.2</b>	1304.9	<b>37.2</b>	1976.7	<b>52.2</b>	2870.4		
<b>7.8</b>	827.7	<b>22.8</b>	1326.3	<b>37.8</b>	2005.5	<b>52.8</b>	2908.4		

Table 20 - R-454B Refrigerant Temperature-Pressure Chart (Imperial)

°F	PSIG	°F	PSIG	°F	PSIG	°F	PSIG	°F	PSIG
20	70.3	47	122.3	74	195.5	101	295.1	128	427.4
21	71.9	48	124.6	75	198.7	102	299.4	129	433.0
22	73.5	49	127.0	76	201.9	103	303.7	130	438.7
23	75.2	50	129.3	77	205.2	104	308.0	131	444.5
24	76.8	51	131.7	78	208.5	105	312.5	132	450.3
25	78.5	52	134.1	79	211.8	106	316.9	133	456.1
26	80.3	53	136.6	80	215.2	107	321.4	134	462.0
27	82.0	54	139.1	81	218.6	108	326.0	135	468.0
28	83.8	55	141.6	82	222.0	109	330.6	136	474.1
29	85.6	56	144.1	83	225.5	110	335.2	137	480.2
30	87.4	57	146.7	84	229.0	111	339.9	138	486.3
31	89.2	58	149.3	85	232.6	112	344.6	139	492.6
32	91.1	59	151.9	86	236.2	113	349.4	140	498.8
33	93.0	60	154.6	87	239.8	114	354.3	141	505.2
34	94.9	61	157.3	88	243.5	115	359.1	142	511.6
35	96.9	62	160.1	89	247.2	116	364.1	143	518.1
36	98.8	63	162.8	90	251.0	117	369.1	144	524.6
37	100.8	64	165.6	91	254.8	118	374.1	145	531.3
38	102.9	65	168.5	92	258.6	119	379.2	146	538.0
39	104.9	66	171.3	93	262.5	120	384.3	147	544.7
40	107.0	67	174.2	94	266.4	121	389.5	148	551.5
41	109.1	68	177.2	95	270.4	122	394.8	149	558.4
42	111.2	69	180.1	96	274.4	123	400.1	150	565.4
43	113.4	70	183.1	97	278.4	124	405.4		
44	115.6	71	186.2	98	282.5	125	410.8		
45	117.8	72	189.3	99	286.7	126	416.3		
46	120.0	73	192.4	100	290.9	127	421.8		

**Refrigerant Filter Driers**

Each refrigerant circuit contains a replaceable core liquid line filter drier. Replace when there is excessive pressure drop across the assembly or moisture is indicated in a liquid line sight glass.

Table 21- Filter Drier Maximum Pressure Drop

Circuit Loading	Max Pressure Drop
100%	34.5 kpa (5 psig)
50%	17.2 kpa (2.5 psig)

The filter driers are provided with pressure taps and shutoff valves for isolation when changing the core. For safety purposes a

service manifold must be attached prior to filter maintenance.



Figure 26 - Replaceable Core Liquid Filter/Driers Suction Filter

In an effort to help protect the compressors from contaminants during testing and startup, AAON factory installs pleated replaceable core suction line filters on the RZ Series.



Figure 27 - RPE-48-BD filter element

One month after startup, remove the RPE-48-BD filter element for the lowest possible pressure drop. Removing the suction line

filter will improve the efficiency and capacity of the unit. AAON installs isolation ball valves on both sides of the suction line filter so the complete system will not have to be reclaimed/evacuated.

#### Suction Filter Removal Instructions

1. Shut down operation of the unit
2. Close both shut-off valves to isolate the suction filter
3. Reclaim the refrigerant from the suction filter section



4. Remove the bolts from the suction filter end plate

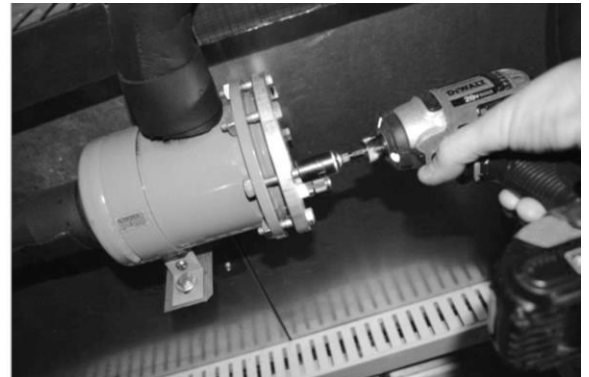

5. Remove the pleated filter assembly

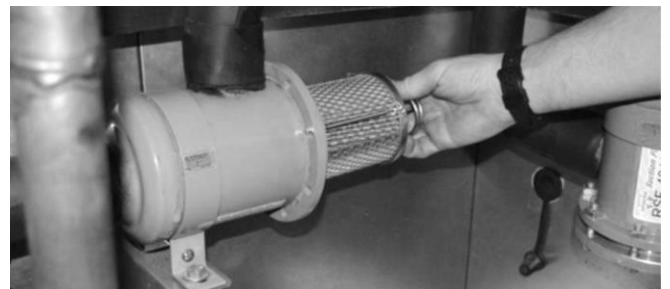

6. Replace the suction filter end plate and bolts

7. Evacuate the suction filter assembly to 300 microns
8. Open both shut-off valves

**VFD Controlled Condenser Fan Startup**

When selected, the condenser fan VFD’s are factory provided and factory programmed. The VFD’s receive input from pressure transducers on each refrigerant circuit and vary the fan speed based on the pressure inputs to maintain a discharge (head) pressure. Standard pressure setpoint is 2.34 Mpa (340 psi) for standard air-cooled systems and 2.76 Mpa (400 psi) for modulating hot gas reheat air-cooled systems.

The AAON Condenser Head Pressure Module is used to maintain a discharge pressure. The VFD is factory wired to the outputs of the AAON Condenser Head Pressure Module. See AAON literature for additional information.

<https://www.aaon.com/Controls>.

**Low Sound Condenser Fan EC Motor Startup**

AAON Condenser Head Pressure Module is used for variable speed control of the motor to maintain a head pressure. The motor must be factory wired to the PWM outputs of the AAON Condenser Head Pressure Module. See AAON literature for further information (<https://www.aaon.com/Controls>).

*Note*

High voltage wires out of the motor:  
 Black & Brown – 1 Phase Line Voltage  
 Green - Ground

Low control voltage wires out of the motor:  
 Blue – Common  
 Yellow – Variable Speed Control

Table 22 - EC Condenser Fan Cycling Options

Color	Terminal	Customer Connection	Option 1	Option 2	Option 3	Option 4	Option 5
Black	0.50 BWS	L1	208-230 VAC	208-230 VAC	208-230 VAC	208-230 VAC	208-230 VAC
Brown	0.50 BWS	L2	208-230 VAC	208-230 VAC	208-230 VAC	208-230 VAC	208-230 VAC
Green	#10 EYELET	Ground	GND	GND	GND	GND	GND
Blue	0.50 BWS	Common	Common	24 VAC	24 VAC	24 VAC	24 VAC
Yellow	0.50 BWS	Signal	PWM		24 VAC		24 VAC
White	0.50 BWS	Signal				24 VAC	24 VAC
Orange	0.50 BWS	Signal		24 VAC		24 VAC	
		RPM	300-1100	300	500	850	1100
		Rotation	CCW	CCW	CCW	CCW	CCW
		ECM Toolbox ID	Variable	Speed 4	Speed 3	Speed 2	Speed 1
		20% PWM RPM	300				
		100% PWM RPM	1100				

## Operation

Unit operations must be controlled with a unit controller, never at the main power supply, except for emergency or complete shutdown of the unit.

### Packaged DX Cooling Operation

When a call for cooling (G and Y1, Y2, etc.) is made the supply fan motors and compressors will energize.

## WARNING

### COMPRESSOR CYCLING

#### 3 MINUTE MINIMUM OFF TIME

To prevent motor overheating compressors must cycle off for a minimum of 3 minutes.

#### 5 MINUTE MINIMUM ON TIME

To maintain the proper oil level compressors must cycle on for a minimum of 5 minutes.

The cycle rate must not exceed 7 starts per hour.

**Note:** When using field controls any variable capacity compressors must run at 100% for 1 minute when starting.

### Indirect Fire Unit Gas Heater Operation

When heat (G and W1, W2, etc.) is called for the combustion motor starts and the ignition control is energized. The control sends 24 VAC to the gas valve and high voltage to the igniter. If a burner flame has been detected within 10 seconds, the spark is extinguished and the flame continues. If a flame has not been detected after 10 seconds, the gas valve closes, the spark ceases and the induced draft blower continues to purge the heat exchanger. After 45 seconds of purge, the ignition system will attempt to light the

burners again. Should no flame be detected after 3 tries, the ignition control will lock out the system. Power to the ignition control shall be cycled to reset the heater control.

On a fault the gas train is shut down by a main limit located in the heat exchanger area or by an auxiliary limit mounted in the supply fan compartment.

### Direct Fire Unit with Return Air Gas Heater Operation

If the unit is in an off state or in a full economizer mode state prior to entering heating mode, a purge sequence is necessary.

1. Outside air damper is closed completely so the unit is operating in 100% return air.
2. Supply fan modulating output is set to the heating mode supply fan output as configured for CAV heating.
3. If fan is not already enabled, supply fan is enabled.
4. Waits up to 30 seconds for the supply fan proving switch to engage.
  - a. If supply fan proving switch does not engage within 30 seconds, an airflow alarm will go off.
5. Continues running with outdoor damper closed and supply fan operating for 3 minutes.

### Direct Fire Unit Gas Heater Operation

1. Pre-purge of the burner with fresh air for 30 seconds. Ignition will not proceed if flame is detected.
2. Pre-ignition of the sparker for 2 seconds in air only.
3. Open the pilot gas valve for 10 seconds and verify pilot flame detection. Safety shutdown occurs if pilot is not detected by the end of 10 seconds.
4. When pilot flame is proven, the sparker is deactivated, main gas valve 1 and 2 are opened and the vent valve is closed.
5. The pilot valve is deactivated after a 10 second main flame establishing time.

6. The modulating gas valve can modulate to maintain capacity based on 0-10 VDC input to the modulating gas valve controller (the modulating gas valve controller sends a 0-20 VDC signal to the modulating gas valve).

### **Electric Heating Operation**

When a call for heating (G and W1, W2, etc.) is made the supply fan motors and electric resistance heaters will energize. Heating is accomplished by passing electrical current through a specified amount of resistance heaters which will produce the required heat.

On a fault condition the main limit located in the supply air or the auxiliary limit located downstream of the supply fan will remove power from all contactors.

### **Steam or Hot Water Preheating and Heating Operation**

Valve control for steam and hot water heating coils are by others. Heating is accomplished by passing steam or hot water through the steam or hot water coil assembly.

### **Chilled Water or Non-Compressorized DX Cooling Operation**

Controls for chilled water cooling coils and non-compressorized DX coil are by others.

## Maintenance

(See back of the manual for maintenance log)

At least once each year, a qualified service technician must check out the unit. Fans, evaporator coils and filters must be inspected monthly.

### Supply Fans

#### **WARNING**

Electric shock hazard. Shut off all electrical power to the unit to avoid shock hazard or injury from rotating parts.

#### **CAUTION**

Blower wheels and bands must be inspected for excessive dust build up periodically and cleaned if required. Excessive dust build up on blower wheels may cause an unbalanced state; leading to vibration and/or component failure. Damages due to excessive dust build up will not be covered under factory warranty.

### Lubrication

All original fan motors and bearings are furnished with factory lubrication. Some applications will require that bearings be re-lubricated periodically. The schedule will depend on the operating duty, temperature variations or other severe atmospheric conditions.

Re-lubricate bearings when at normal operating temperatures, but not running. Rotate the fan shaft by hand and add only enough grease to purge the seals. **DO NOT OVER LUBRICATE.**

Recommended greases are:  
SHELL OIL - DOLIUM R  
CHEVRON OIL - SRI No. 2  
TEXACO INC. - PREMIUM RB

### DX Cooling

Set unit controls to cooling mode of operation with supply fans on. Check the fans for correct operating direction, amperage and voltage. Check compressor operation, rotation, amperage and voltage to the unit nameplate (check the amperage on the load side of the compressor contactor).

### Condensate Drain Pans

Drain pans will have moisture present and require periodic cleaning to prevent microbial growth. Cleaning of the drain pans will also prevent any possible plugging of the drain lines and overflow of the pan itself. Cleaning of the drain pans and inside of the unit must be done only by qualified personnel.

### Filter Replacement

Monthly filter inspection is required to maintain optimum unit efficiency.

Replace filter media monthly. Filters are located either upstream of the evaporator coil, upstream of the blow-through supply blowers, or in the final filter position. Replace filters with the size indicated on each filter or as shown in the in the filter charts in the back of this manuel. Arrow on the replacement filters must point on the direction of airflow.

### Brazed Plate Heat Exchanger Cleaning

Because of a normally high degree of turbulence in brazed plate heat exchangers, for many applications the heat exchanger channels are self cleaning. For applications that are not self cleaning (i.e. hard water at high temperatures, etc.) or applications where additional cleaning is desired, it is possible to



clean the brazed plate heat exchanger by circulating a cleaning liquid.

Use a tank with weak acid, 5% phosphoric acid (H<sub>3</sub>PO<sub>4</sub>) or, if the exchanger is frequently cleaned, 5% oxalic acid (H<sub>2</sub>C<sub>2</sub>O<sub>4</sub>). Pump the cleaning liquid through the exchanger. For optimum cleaning, the cleaning solution flow rate must be a minimum of 1.5 times the normal flow rate, preferably in a back-flush mode. After cleaning, the heat exchanger must be rinsed with clean water. A solution of 1-2% sodium hydroxide (NaOH) or sodium bicarbonate (NaHCO) before the last rinse ensures that all acid is neutralized.

### **Air-Cooled Condenser**

The air-cooled condenser section rejects heat by passing outdoor air over the microchannel coils for cooling of the hot refrigerant gas from the compressors. The heated air will discharge from the top of the section through the axial flow fans.

Inspect the condenser coils annually to ensure unrestricted airflow. If the installation has a large amount of airborne dust or other material, clean the condenser coils with a water spray in a direction opposite to airflow. Care must be taken to prevent damage to the coils.

### **E-Coated Coil Cleaning**

Documented routine cleaning of e-coated coils is required to maintain coating warranty coverage for fin and tube and microchannel coils. See the AAON E-Coated Coil Maintenance Record sheet.

## **WARNING**

Electric shock hazard. Shut off all electrical power to the unit to avoid shock hazard or injury from rotating parts.

Surface loaded fibers or dirt must be removed prior to water rinse to prevent restriction of airflow. If unable to backwash the side of the coil opposite of the coils entering air side, then surface loaded fibers or dirt must be removed with a vacuum cleaner. If a vacuum cleaner is not available, a *soft non-metallic* bristle brush may be used. In either case, the tool must be applied in the direction of the fins. Coil surfaces can be easily damaged (fin edges bent over) if the tool is applied across the fins.

Use of a water stream, such as a garden hose, against a surface loaded coil will drive the fibers and dirt into the coil. This will make cleaning efforts more difficult. Surface loaded fibers must be completely removed prior to using low velocity clean water rinse.

A *monthly* clean water rinse is recommended for coils that are applied in coastal or industrial environments to help to remove chlorides, dirt, and debris. It is very important when rinsing, that water temperature is less than 54.4°C (130°F) and pressure is less than 689.5 kpa (100 psig) to avoid damaging the fin edges. An elevated water temperature (not to exceed 54.4°C [130°F]) will reduce surface tension, increasing the ability to remove chlorides and dirt.

 **CAUTION**

High velocity water from a pressure washer or compressed air must only be used at a very low pressure to prevent fin and/or coil damages. The force of the water or air jet may bend the fin edges and increase airside pressure drop. Reduced unit performance or nuisance unit shutdowns may occur.

***Quarterly cleaning is essential to extend the life of an e-coated coil and is required to maintain coating warranty coverage.***

Coil cleaning shall be part of the unit's regularly scheduled maintenance procedures. Failure to clean an e-coated coil will void the warranty and may result in reduced efficiency and durability.

 **CAUTION**

Harsh chemicals, household bleach, or acid cleaners must not be used to clean outdoor or indoor e-coated coils. These cleaners can be very difficult to rinse out of the coil and can accelerate corrosion and attack the e-coating. If there is dirt below the surface of the coil, use the recommended coil cleaners.

For routine quarterly cleaning, first clean the coil with the below approved coil cleaner. After cleaning the coils with the approved cleaning agent, use the approved chloride remover to remove soluble salts and revitalize the unit.

***Recommended Coil Cleaner***

The following cleaning agent, when used in accordance with the manufacturer's

directions on the container for proper mixing and cleaning, has been approved for use on e-coated coils to remove mold, mildew, dust, soot, greasy residue, lint, and other particulate:

Enviro-Coil Cleaner: AAON PN: V82540

GulfClean™ Coil Cleaner ; AAON PN: G074480

***Recommended Chloride Remover***

GulfClean Salt Reducer™ ; AAON PN: G074490

GulfClean Salt Reducer™ is used to remove soluble salts from the e-coated coil, follow the manufacturer's instructions. This product is not intended for use as a degreaser. Any grease or oil film must first be removed with GulfClean™ Coil Cleaner.

Remove Barrier - First ensure the power to the unit is off and locked out. Clean the area around the unit if needed to ensure leaves, grass or loose debris will not be blown into the coil. Soluble salts adhere themselves to the substrate. For the effective use of this product, the product must be able to come in contact with the salts. These salts may be beneath any soils, grease or dirt; therefore, these barriers must be removed prior to application of this product. As in all surface preparation, the best work yields the best results.

Application - Apply GulfClean™ Coil Cleaner directly onto the substrate. Sufficient product must be applied uniformly across the substrate to thoroughly wet out surface, with no areas missed. This may be accomplished by use of a pump-up sprayer or conventional spray gun. Apply the cleaner to unit interior air exiting side coil surfaces first. Work in sections/panels

moving side to side and from top to bottom. Allow the cleaning solution to soak for 5 to 10 minutes. Then move on to the exterior using the same method.

Rinse - Using pressurized potable water such as a garden hose, (< 689.5 kpa [100 psi]), rinse the coils and continue to always work in sections/panels.

Continue until all coil areas on the inside of the unit have been rinsed. **Note: Coils must always be cleaned / back flushed, opposite of airflow to prevent impacting the dirt into the coil.**

Repeat these steps with GulfClean™ Salt Reducer. When finished replace all panels and tops that were removed.

### Microchannel Coil Cleaning

Cleaning microchannel coils is necessary in all locations. In some locations it may be necessary to clean the coils more or less often than recommended. Condenser coil must be cleaned at a minimum of once a year. In locations where there is commonly debris or a condition that causes dirt/grease build up it may be necessary to clean the coils more often. Proper procedure must be followed at every cleaning interval. Using improper cleaning technique or incorrect chemicals will result in coil damage, system performance fall off, and potentially leaks requiring coil replacement.

Documented routine cleaning of microchannel coils with factory provided e-coating is required to maintain coating warranty coverage. Use the E-Coated Coil Cleaning section for details on cleaning e-coated coils.

Field applied coil coatings are not recommended with microchannel coils.

### Allowed Chemical Cleaners and Procedures

AAON recommends certain chemicals that can be used to remove buildup of grime and debris on the surface of microchannel coils. These chemicals have been tested for performance and safety and are the only chemicals that AAON will warrant as correct for cleaning microchannel coils.

There are two procedures that are outlined below that will clean the coils effectively without damage to the coils. Use of any other procedure or chemical may void the warranty to the unit where the coil is installed. **With all procedures make sure the unit is off before starting.**

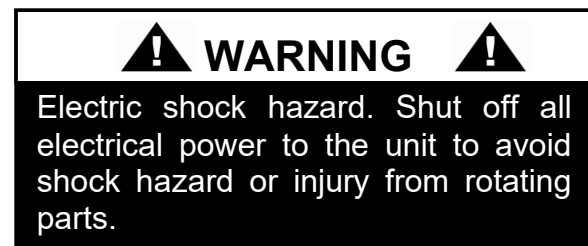

The water pressure used to clean must not exceed 689.5 kpa (100 psi), from no closer than 15.25 centimeters (6 inches) from the coils, and with the water aimed perpendicular to the coils.

### #1 Simple Green

Simple Green is available from AAON Parts and Supply (Part# T10701) and is biodegradable with a neutral 6.5 pH A 4 to 1 solution is recommended. Use the following procedure.

1. Rinse the coil completely with water. Use a hard spray but be careful not to bend or damage the fins. A spray that is too hard will bend the fins. Spray from the fan side of the coil.
2. With a pump sprayer filled with a mix of 4 parts water to one part Simple Green spray the air inlet face of the coil. Be sure to cover all areas of the face of the coil.

3. Allow the coil to soak for 10-15 minutes.
4. Rinse the coil with water as in step one.
5. Repeat as necessary.

### **#2 Water Flush**

This procedure can be used when the only material to cause the coil to need cleaning is debris from plant material that has impinged the coil face.

1. Rinse the coil completely with water. Use a hard spray but be careful not to bend or damage the fins. A spray that is too hard will bend the fins. Spray from the fan side of the coil.
2. Spray and rinse the coil from the face.

 <b>CAUTION</b>
<p>Use pressurized clean water, with pressure not to exceed 689.5 kpa (100 psi). Nozzle must be 15.25 centimeters (6") and perpendicular to the coil face. Failure to do so could result in coil damage.</p>

### **Application Examples**

The two procedures can be used to clean microchannel coils. They will fit with the application depending on the area. In some areas where the spring/summer has a large cottonwood bloom #2 might work fine if the unit is installed on an office building and no other environmental factors apply.

Generally the best and broadest based procedure is #1. The grease cutting effect of the Simple Green is good for restaurant applications.

### **Other Coil Cleaners**

There are many cleaners on the market for condenser coils. Before using any cleaner

that is not covered in this section you must get written approval from the AAON warranty and service department. Use of unapproved chemicals will void the warranty.

AAON testing has determined that unless a chemical has a neutral pH (6-8) it must not be used.

Beware of any product that claims to be a foaming cleaner. The foam that is generated is caused by a chemical reaction to the aluminum fin material on tube and fin coils and with the fin, tube, and coating material on microchannel coils.

Microchannel coils are robust in many ways, but like any component they must be treated correctly. This includes cleaning the coils correctly to give optimal performance over many years.

### **Roofing**

The cleaning procedures outlined here use relatively benign ingredients. When working with a rooftop unit care must be taken to make sure the chemicals will not adversely affect the roof coating. Checking with the roofing supplier/manufacturer is the best way to proceed. If the roofing supplier/manufacturer is not available testing of the chemicals on the roof coating is recommended.

Commercial roofing material manufacturers using PVC and EPDM have been contacted and indicate that there should be no problem with any of the procedures outlined above.

## **Options**

(See back of the manual for maintenance log)

### **Heating Coils**

One or two row hot water and steam heating and preheating coils can be factory installed. All valve controls for heating operation are field supplied and field installed. Hot water

and steam coil connections are spun copper tube.

Water coils must not be subjected to entering air temperatures below 3.3°C (38°F) to prevent coil freeze-up. If air temperature across the coil is going to be below this value, use a glycol solution to match the coldest air expected.

**! WARNING**

Piping, pressure limiting devices, backflow preventers and all other safety requirements shall be in accordance with national and local codes.

**! CAUTION**

The unit shall have proper sealing of the water piping entries into the unit. Failure to seal the entries may result in damage to the unit and property.

Table 23 - Hot Water Coil Connection Sizes

Model (RZA-)	Heating Coil Size	Hot Water Coil Connection Size	Coil Quantity*
045, 055, 065, 075	A, B, C, D	2-1/8"	1/1
090, 105, 120, 130, 140	A	2-1/8"	2/2
	B, C, D	2-1/8"	1/1
145, 160, 180, 200, 220, 240	A, B	2-1/8"	2/2
	C, D	2-1/8"	1/1

Note: 2 1/8" = 54 mm

\* In/Out Connections

Table 24 - Steam Distributing Coil Connection Sizes

Model (RZA-)	Heating Coil Size	Steam Coil Connection Size	Coil Quantity*
045, 055, 065, 075	A	2-1/8"	2/2
	B, C, D	2-1/8"	1/1
090, 105, 120, 130, 140	A	2-1/8"	4/4
	B	2-1/8"	2/2
	C, D	2-1/8"	1/1
145, 160, 180, 200, 220, 240	A	2-1/8"	4/4
	B,C	2-1/8"	2/2
	D	2-1/8"	1/1

Note: 2 1/8" = 54 mm

\* In/Out Connections

### Chilled Water Coil

Four, six, or eight row chilled water cooling coils can be factory installed. All valve controls for cooling operation are field supplied and field installed. Chilled water coil connections are spun copper tube.

Table 25 - Chilled Water Coil Connection Sizes

Model (RZA-)	Chilled Water Coil Connection Size	Coil Quantity*
045, 055, 065, 075, 090, 105, 120, 130, 140	2 5/8"	4/4
145, 160, 180, 200, 220, 240	2 5/8"	8/8

Note: 2 5/8" = 66.7 mm

\* In/Out Connections

Table 26 - Min and Max Water Pressures and Temps

	Chilled Water	Hot Water
Min. Entering Air	15.6°C (60°F)	4.4 °C (40°F)
Max Entering Air	37.8°C (100°F)	26.7°C (80°F)
Min. Entering Water	1.7°C (35°F)	60°C (140°F)
Max Entering Water	18.3°C (65°F)	93.3°C (200°F)
Min. Water Pressure	0 kpa (15 psig)	
Max Water Pressure	2068kpa (300 psig)	

**Packaged Direct Expansion (DX) Units**

**! WARNING**

**COMPRESSOR CYCLING**

**3 MINUTE MINIMUM OFF TIME**  
To prevent motor overheating compressors must cycle off for a minimum of 3 minutes.

**5 MINUTE MINIMUM ON TIME**  
To maintain the proper oil level compressors must cycle on for a minimum of 5 minutes.

The cycle rate must not exceed 7 starts per hour.

**! CAUTION**

**CRANKCASE HEATER OPERATION**

Some units are equipped with compressor crankcase heaters, which must be energized at least 24 hours prior to cooling operation, to clear any liquid refrigerant from the compressors.

All DX refrigeration systems are factory assembled, leak tested, charged withrefrigerant, and run tested.

All refrigerant systems include evaporator and condenser coils. Each unit includes replaceable core liquid line filter driers, replaceable suction filters, compressor

isolation valves, electronic expansion valves, and variable speed scroll compressors.

Never turn off the main power supply to the unit, except for servicing, emergency, or complete shutdown of the unit. When power is cut off from the unit, crankcase heaters

cannot prevent refrigerant migration into the compressors. This means the compressor may cool down and liquid refrigerant may accumulate in the compressor. The compressor is designed to pump refrigerant gas and damage may occur when power is restored if liquid enters the compressor.

If power to the unit must be off for more than an hour, turn the unit off at the control panel, and leave the unit off until the main power switch has been turned on again for at least 24 hours for units with compressor crankcase heaters. This will give the crankcase heater

time to clear any liquid accumulation out of the compressor before it is started.

Always control the unit from the control panel, never at the main power supply, except for emergency or complete shutdown of the unit.

During the cooling season, if the airflow is reduced due to dirty air filters or any other reason, the cooling coils can get too cold which will cause excessive liquid to return to the compressor. As the liquid concentration builds up, oil is washed out of the compressor, leaving it starved for lubrication.

Compressor life will be shorted by reduced lubrication and the pumping of excessive amounts of liquid oil and refrigerant.

### CAUTION

Polyester (POE) and Polyvinyl ether (PVE) oils are two types of lubricants used in hydrofluorocarbon (HFC) refrigeration systems. Refer to the compressor label for the proper compressor lubricant type.

Air-cooled DX units without a low ambient option, such as condenser fan cycling or the -17.8°C (0°F) low ambient option, will not operate in the cooling mode of operation properly when the outdoor temperature is below 12.8°C (55°F). Low ambient and/or economizer options are required if cooling operation below 12.8°C (55°F) is expected.

#### **Note: Multiple Units with Multiple Unit Controllers**

When several heating and cooling units are used to condition a space, all unit controllers must be set in either heating mode, cooling mode or off. Do not leave part of the units switched to the opposite mode. Cooling only

units must be switched off during the heating season.

#### *Evaporator Coil*

### WARNING

Electric shock hazard. Shut off all electrical power to the unit to avoid shock hazard or injury from rotating parts.

#### *Removal*

Isolate the evaporator section and recover the refrigerant in that section. Make sure to weigh the amount of refrigerant recovered.

Remove the expansion valve bulbs and/or the valve controller from the suction lines.

Disconnect the suction and liquid line copper connections to the evaporator coil.

Depending on the configuration, remove additional components such as filters, reheat coils or UV lights to allow the coil to be removed.

Remove screws attaching access side, back, and top blank-off panels to the evaporator coil and the unit.

Remove the evaporator coil through the door opening.

#### *Reinstallation*

Place the evaporator coil back in the unit drain pan. There should be about a 6.4 mm (1/4") gap between the upstream side of the coil and the back of the drain pan.

Secure the coil to the back wall of the unit with the blank-off panel. Attach the top and access side blank-off panels to the coil.

Connect the suction and liquid copper connections to the evaporator coil. Reinstall the expansion valve bulbs and/or the valve controller on the suction lines.

Depending on the configuration, additional components might need to be reinstalled.

Evacuate the evaporator section and then return the refrigerant that was previously removed from this section.

See Adjusting Refrigerant Charge section to check for proper sub-cooling and superheat of the refrigerant systems.

#### *Condenser Fans*

Condenser fans are located on top of the unit. Condenser fans and motors can be removed and reinstalled as individual assemblies.

 <b>WARNING</b>
Electric shock hazard. Shut off all electrical power to the unit to avoid shock hazard or injury from rotating parts.

 <b>WARNING</b>
Improper installation, adjustment, alteration, service, or maintenance can cause property damage, personal injury, or loss of life. Startup and service must be performed by a Factory Trained Service Technician.

#### *Removal*

Take off the fan grill by removing the screws that attach it to the orifice.

Disconnect the condenser fan motor wires.

Remove the screws that attach the orifice to the condenser assembly.

With the wires disconnected and the screws removed, the fan, motor and orifice assembly can be lifted off the unit.

#### *Reinstallation*

Set the condenser fan, motor and orifice assembly back into the condenser assembly with the motor wires on the side closest to the control panel.

Attach the orifice to the condenser assembly using all of the points where screws were removed.

Reconnect the fan motor wires.

Attach the fan grill at all of the points where screws were removed.

#### **Evaporative Condenser**

Evaporative cooling equipment rejects heat by evaporating a portion of the recirculated water spray and discharging it from the unit with the hot, saturated air. In the right conditions this can be substantially more efficient than other condenser setups. This comes with its set of maintenance.

As the spray water evaporates, it leaves behind the mineral content and impurities of the supply water. If these residuals are not purged from the water distribution system, they will become concentrated and lead to scaling, corrosion, sludge build-up and biological fouling. A water treatment monitoring and control system has been furnished with this unit. Be sure to read the complete manual that has been furnished. All water treatment is a combination of bleed water and chemical treatment for proper control of the residuals and to prevent any biological contamination.



**! WARNING**

Batch-loading chemicals into the unit is NOT PERMITTED. The control system must regulate the chemical feed.

*Evaporative Condenser Location*

The recirculating water system contains chemical additives for water quality control and biological contaminants removed from the air by the washing action of the water. Personnel exposed to the saturated effluent, drift, or direct contact must use proper precaution. Proper location of the evaporative condenser requires good judgment to prevent the air discharge from entering fresh air intakes or to avoid allowing contaminated building exhaust from entering the condenser.

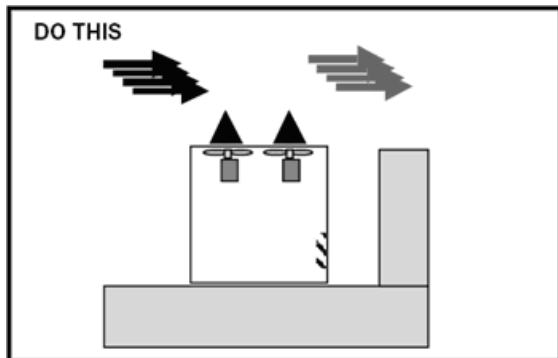

Figure 28 - Proper Unit Location

Follow local and national codes in locating the evaporative condenser but as minimum the evaporative condenser sump must be 4.6 meters (15 feet) from the nearest intake.

**! WARNING**

The evaporative condenser must be thoroughly cleaned on a regular basis to minimize the growth of bacteria, including Legionella Pneumophila, to avoid the risk of sickness or death. Service personnel must wear proper personal protective equipment. Do not attempt any service unless the fan motor is locked out.

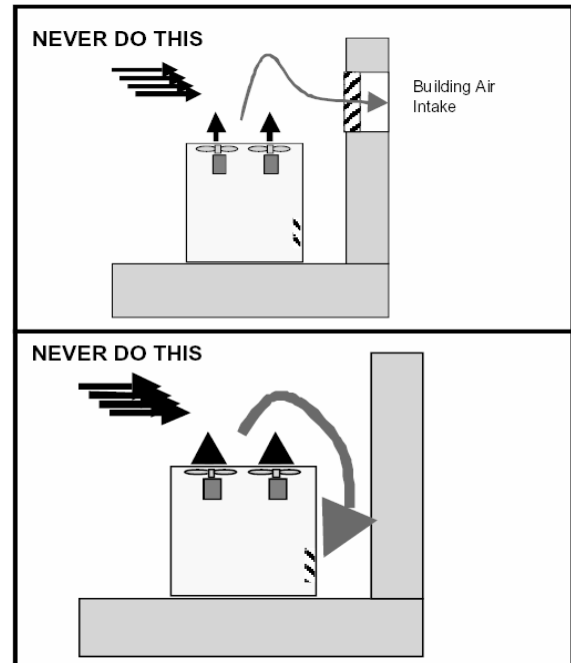

Figure 29 - Improper Unit Locations

**Performance**

Improper location of the evaporative condenser may seriously degrade the capacity of the equipment. Make sure the equipment is located such that discharge air from the condenser does not enter the condenser air inlet.

### *Evaporative Condenser Installation*

Evaporative Condensers require two field water connections for installation: City Makeup Water Connection and Drain Connection. City Makeup Water uses a 6.4mm (3/4") FPT connection. The Drain uses 50.8mm (2") PVC socket connection. Connect the drain to a sanitary sewer or other code permitted drain. These connections can go through the base or the wall of the unit, depending on the configuration of the unit.

### **Temporary Drain-Evaporative Condenser**

The evaporative condenser design is not sealed to the outdoors. Some rainwater might enter the sump tank during transportation. AAON provides a temporary drain system while the unit is in transit. The temporary drain consist of an adapter that will connect a hose from the sump drain to the base drain. This temporary drain must be replaced by permanent draining piping once on site.

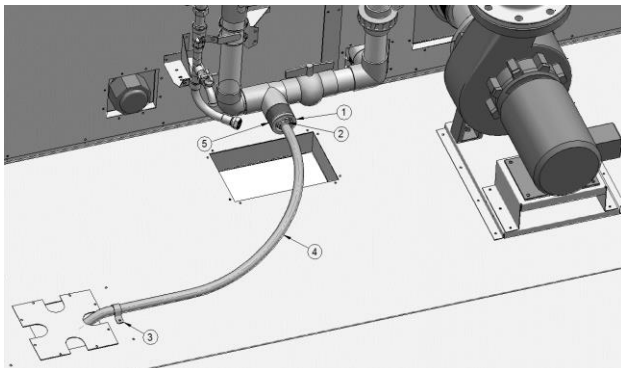

Figure 30 - Temporary Drain Components

Once the unit is ready for permanent draining, close the valve and remove the temporary draining system. The components that must be removed are those with number callouts in Figure 30. The drain connection for the permanent draining is 50.8mm (2") PVC.

### **Condenser Tube Inspection**

The coil is leak tested at 3.1 MPa (450 psig) before shipment. AAON will not be

responsible for loss of refrigerant. It is the responsibility of the installer to verify that the system is sealed before charging with refrigerant. If the unit is operated during low ambient temperature conditions, freeze protection for the recirculating water system must be provided.

### *Evaporative Condenser Operation*

#### **Pre Start-Up**

Do not start the evaporative condenser or compressors without installation of proper water treatment chemicals. Contact your local water treatment expert for correct selection of water treatment chemical, adjustment of chemical feed and bleed rates.

#### **Cleanliness**

Dirt and debris may accumulate in the sump during shipping and storage. The sump must be cleaned prior to start-up to prevent clogging the water distribution system. Any surfaces that show contamination must be cleaned ONLY with a commercial stainless steel cleaner to restore the initial appearance. The inlet screens must be inspected for foreign material.

#### **Freeze Protection**

In order to prevent water temperatures from dropping below 10°C (50°F) during operation, this unit is equipped with a VFD controls for the condenser fans.

#### **Recirculating Water System**

Electric sump heaters are available to keep the sump water from freezing when the refrigeration system is not operating. An electric resistance heater is supplied in the vestibule when sump heaters are selected.

**Note:** The condenser must not be operated with the fan on and the pump cycled on and off to maintain head pressure control under any conditions. The unit is equipped with a water temperature controller which varies fan speed to maintain sump water temperature.

This unit is not equipped with a compressor discharge pressure controller for fan speed modulation and therefore cannot be operated without water flow.

### **Pump Operation**

Before initial start of the pump, check as follows:

1. Be sure that pump operates in the direction indicated by the arrow on the pump casing. Check rotation each time motor leads have been disconnected.
2. Check all connections of motor and starting device with wiring diagram. Check voltage, phase and frequency of line circuit with motor name plate.
3. Check suction and discharge piping and pressure gauges for proper operation.
4. Turn rotating element by hand to assure that it rotates freely.

### **Running**

Periodically inspect pump while running, but especially after initial start-up and after repairs.

1. Check pump and piping for leaks. Repair immediately.
2. Record pressure gauge readings for future reference.
3. Record voltage, amperage per phase, and kW.

### **Condenser Fan Motors**

The direct-drive condenser motors on AAON evaporative condensers are 1200-rpm premium efficiency motors controlled by a VFD. These motors are totally enclosed air over motors with weep holes in the bottom end bell so that any condensation can drain out of the motor.

The motors have a small electric resistance heater installed inside the casing to keep the motors warm when they are deactivated. The heaters are designed to keep the interior of the motor  $-12.2^{\circ}\text{C}$  ( $10^{\circ}\text{F}$ ) warmer than the surrounding ambient temperature. This prevents condensation from

forming inside the motor. Ensure that fan is tightly mounted to the motor shaft and the motor mounting bolts are aligned and secure.

### **Water Makeup Valve**

The sump water level is controlled by a set of conductivity probes at different levels in the sump. The standard sump water level is about 38.1 centimeters (15 inches) deep. This water level controller is located in the vestibule behind the condenser pump. There are four conductivity probes in this controller. There is a reference probe (shown as “ref” on the wiring diagram). This probe is one of the two longest probes. The other long probe is the low water level probe (shown as “lo” on the wiring diagram). The medium length probe is for the medium water level (shown as “med” on the wiring diagram). The short probe is for the high water level (shown as “hi” on the wiring diagram).

There is a solenoid valve in the makeup water line that is activated by the water level controller. The water level controller determines the level of water in the sump based on conductivity between two probes. If the controller sees conductivity between two probes, it knows that water is at least at the level of that probe.

If the water in the sump is below the low probe, it will not allow the condenser pump or the sump heater to operate. It will activate the makeup water solenoid to try to fill the sump assuming water is flowing to the unit. Once water is above the low probe, it will allow the condenser pump and sump heater (if ordered and the ambient temperature is below  $4.4^{\circ}\text{C}$  ( $40^{\circ}\text{F}$ )) to operate. The makeup water solenoid will remain activated until water gets to the high water level. When the water gets to the high water level, the makeup water solenoid will deactivate until water gets to the medium water level. In normal operation, the

water level will swing between the medium and high water levels. The maximum high water level must be 1" below the overflow drain which occurs after the makeup water valve shuts off when the water level reaches the high level probe.

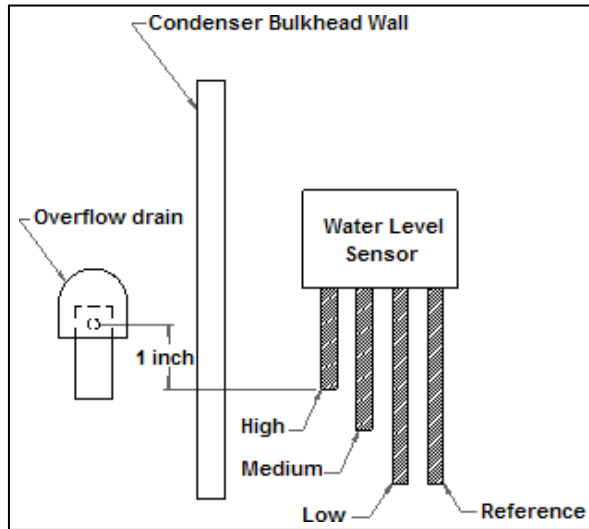

Figure 31 - Water Makeup Valve

Maintain makeup water supply pressure between 103.4 and 413.7 kpa (15 and 60 psig) for proper operation of the valve. The makeup water valve assembly must be inspected monthly and adjusted as required. Replace the valve seat if leakage occurs when the valve is in the closed position.

### Water Treatment System

All AAON evaporative condensers come equipped with a water treatment system that must be maintained by a local water treatment professional trained in the water treatment of evaporative condensers. This system consists of a controller, three chemical pumps and storage tanks, a conductivity sensor, a motorized ball valve for water bleed, and a water meter.

One chemical pump and tank is typically used for a de-scaling chemical to prevent scale from forming in the condenser. The other two pumps and tanks are typically used

for two different biocides (to kill any microorganisms that could grow in the condenser). Two biocides are used to prevent organisms from becoming resistant to one chemical.

The mineral content of the water must be controlled. All makeup water has minerals in it. As water is evaporated from the condenser, these minerals remain. As the mineral content of the water increases, the conductivity of the water increases. The water treatment controller monitors this conductivity. As the water conductivity rises above set point, the controller will open a motorized ball valve on the discharge side of the condenser pump and dumps water into the condenser drain until conductivity is lowered. While the motorized ball valve is opened, the controller will not disperse chemicals.

The chemicals are dispersed by the water treatment controller based on the scheduled input by the water treatment professional. The water meter measures the quantity of makeup water used by the condenser.

Any water treatment program must be compatible with stainless steel, copper, aluminum, ABS plastic and PVC. Batch feed processes must never be used as concentrated chemicals can cause corrosion. Never use hydrochloric acid (muriatic acid) as it will corrode stainless steel.

### Evaporative Condenser Sequence of Operation

On a call for cooling, the condenser pump is activated. A pressure switch in the pump discharge is bypassed for six seconds by a time delay relay in order for the pump to establish recirculating water flow. If flow is not proven within the six seconds, the pressure switch opens, breaking the safety circuit, thereby shutting down the entire

system. This pressure switch is set to close at 20.7 kpa (3 psi) and open at 6.9 kpa (1 psi).

A sensor measures the water temperature in the pump discharge line. If the sump water temperature exceeds 40.6°C (105°F), the cooling system will be shut down thereby preventing damage to the evaporative condenser.

If a fault occurs in the evaporative condenser fan motor VFD, normally closed fault terminals on the VFD will interrupt the safety circuit, thereby shutting down the system.

The controls send a 0-10 VDC signal to the VFD based on the water temperature sensor. The controls are set to maintain a sump temperature of 21.1°C (70°F). On a rise in sump temperature, the controls will increase the speed of the condenser fans. Conversely, on a drop in sump temperature, the controls will decrease the speed of the condenser fans.

An outside air thermostat does not allow the condenser to operate when the ambient temperature is below 1.7°C (35°F).

#### *Evaporative Condenser Maintenance*

The following recommended maintenance procedures are basic requirements for normal operating environments. For severe operating conditions, the frequency of inspection and service must be increased. Air containing industrial and chemical fumes, salt, dust, or other airborne contaminants and particulates will be absorbed by the recirculating water system and may form solutions and deposits harmful to the products and personnel.

#### **Storage**

Pumps removed from service and stored, must be properly prepared to prevent excessive rusting. Pump port protection plates must not be removed until the pump is ready to connect to the piping. Rotate the shaft periodically (At least monthly) to keep

rotating element free and bearings fully functional.

For long term storage, the pump must be placed in a vertical position in a dry environment. Internal rusting can be prevented by removing the plugs at the top and bottom of the casing and drain or air blow out all water to prevent rust buildup or the possibility of freezing. Be sure to reinstall the plugs when the unit is made operational. Rust-proofing or packing the casing with moisture absorbing material and covering the flanges is acceptable. When returning to service be sure to remove the drying agent from the pump.

#### **Pump Maintenance**

Cleaning - Remove oil, dust, water, and chemicals from exterior of motor and pump. Keep motor air inlet and outlet open. Blow out interior of open motors with clean compressed air at low pressure.

Labeled Motors - It is imperative for repair of a motor with Underwriters' Laboratories label that original clearances be held; that all plugs, screws, other hardware be fastened securely, and that parts replacements be exact duplicates or approved equals. Violation of any of the above invalidates Underwriters' Label.

#### **Fan Motor Maintenance**

Same as pump maintenance

#### **Access Doors**

If scale deposits or water is found around the access doors, adjust door for tightness. Adjust as necessary until leaking stops when door is closed.

The evaporative condenser doors have an adjustable fit design. A good seal and fit are key to avoid leaks. A leak inspection is recommended during installation and every

six (6) months thereafter. If a leak is found, use the following steps to adjust the fit of the door. This process will require at least two (2) people.

1. Identify and locate the leak(s).
2. Make sure the evaporative condenser is not running before adjusting the access doors.
3. Open the door and check for damage to the seal or the frame, as well as the engagement of the door seal with the frame.
4. Replace the seal if damage is found.
5. Check if this fixed the issue.
6. If the issue persists, the next step is to check the fit of the door.
7. Disengage the closing mechanism of the door that has a leak.
8. This is a two (2) person operation, one person must hold the door, while the other slowly loosens the four (4) bolts on the two (2) hinges connecting the door to the hinge.

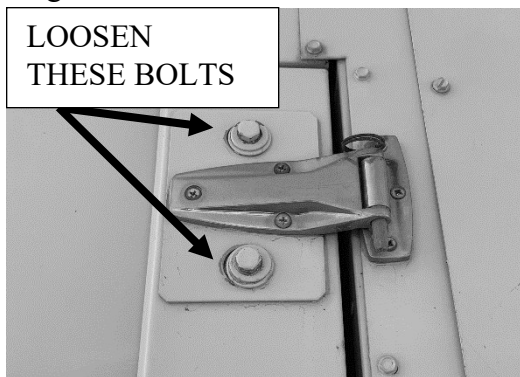

Figure 32 - Evaporative condenser access door

9. Adjust the door against the seal as needed to create a good seal all around the door.
10. Hold the door in place and tighten the bolts to secure the door in place.
11. Run the evaporative condenser and check to make sure the issue has been solved.

12. If the issue persists, repeat these steps as needed.

### **Bearings - Lubrication**

Every 6 months or after a prolonged shut down. Use waterproof, lithium based grease. Below 0°C (32°F) - Esso Exxon or Beacon 325. Above 0°C (32°F) – Mobil Mobilox EP2, Shell Alvania EP2 or Texaco RB2.

### **Recommended Monthly Inspection**

1. Clean sump section interior. Dirt and other impurities which have accumulated in the sump must be removed from the sump area.
2. Shut off makeup water ball valve and open the drain connection to flush for flushing of the sump.
3. Clean dirt out of sump using a water hose (not a pressure washer).
4. Clean sump suction strainer and for any obstruction on the drain pipes.
5. Check water operating level.
6. Inspect fan motor(s) and water circulation pump(s) and lubricate per the lubrication nameplate or manufacture's recommendations.
7. Inspect axial fans and eliminators removing any debris which may have accumulated during operation.
8. Inspect the water distribution system to insure that nozzles and spray orifices are functioning correctly. The inspection must be made with the circulation pump on and fans off.
9. Inspect for any signs of leaks.

### **Mist Eliminators**

The mist eliminators must be correctly positioned when they are replaced during cleaning or service.

### **Air Inlet**

Inspect the air inlet louvers and mist eliminators into the condenser section on a monthly basis to remove any paper, leaves or other debris that may block the airflow.

### **Stainless Steel Base Pan**

The base pan under the tube bundles is stainless steel and may sometimes become tarnished due to contamination. These surfaces must be inspected yearly to ensure they remain clean of any contamination that may result in damage. Any surfaces that show contamination must be cleaned **ONLY** with a commercial stainless steel cleaner to restore the initial appearance.

### **Propeller Fans and Motors**

The fans are directly mounted on the motor shafts and the assemblies require minimal maintenance except to assurance they are clear of dirt or debris that would impede the airflow.

### **Recommended Annual Inspection**

In addition to the above maintenance activities, a general inspection of the unit surface must be completed at least once a year. Remove spray header and flush out.

### **Cleaning**

Mechanical cleaning, including pressure washing, must never be performed as surfaces and seals could be damaged. Chemical cleaning that is safe for stainless steel, copper, aluminum, ABS plastic and PVC is the only acceptable means of cleaning the evaporative condenser. A proper water treatment program should reduce cleaning needs.

Do not attempt to mechanically clean the copper tubing in the evaporative condenser. Do not use wire brushes or any other mechanical device on the copper tubing. Severe damage may result. Contact your

water treatment expert for recommendations on chemical cleaning procedures.

### **Warranties**

Please refer to the limitation of warranties in effect at the time of purchase.

### *Evaporative Condenser Water Quality*

Cycles of concentration (the ratio of dissolved solids in recirculated water to dissolved solids in makeup), must be determined and monitored frequently by a competent water treatment expert.

To limit cycles of concentration to maintain the water quality, it is necessary to “bleed” a certain portion of the recirculated water. This is achieved automatically with a solenoid valve actuated by a conductivity meter set at the desired conductivity corresponding to the desired cycles of concentration. Consult a water treatment expert who has experience with evaporative condensers to determine the desired water quality.

All AAON evaporative condensers are furnished with a bleed system fitting and valve to continuously remove a small portion of the recirculated water to keep the water quality within the above listed parameters. This device is located on the discharge side of the pump. It is important to note that since “bleed” rate is a function of evaporation rate (i.e., amount of heat rejected), if the bleed setting is manual based on design heat load, too much water will be removed when the heat load is less than design.

The AAON evaporative condenser is equipped with a desuperheater. The desuperheater coil is located above the eliminators. Approximately 22% of the total heat of rejection is accomplished with the desuperheater. Water usage of the AAON evaporative condenser is approximately 22%

less than evaporative condensers not equipped with a desuperheater.

One method of calculating evaporation and bleed in gallons per minute (gpm) is shown as follows:

$$\begin{aligned}
 &\textbf{Evaporation Rate} \\
 &= \frac{\text{Total Heat of Rejection via Evaporation}}{h_{fg} \text{ btu/lb} \times \rho \text{ lb/gal} \times 60 \text{ min/hr}} \\
 &= \frac{\text{Total Heat of Rejection via Evaporation}}{525,000 \text{ (Btu/hr/gpm)}} \\
 \\
 &\textbf{Bleed Rate} \\
 &= \frac{\text{Evaporation Rate}}{\text{Cycles of Concentration} - 1}
 \end{aligned}$$

$$\begin{aligned}
 &\textbf{Evaporation Rate} \\
 &= \frac{1,148,971 \text{ (Btu/hr)}}{525,000 \text{ (Btu/hr/gpm)}} \\
 &= 2.19 \text{ gpm} \\
 \\
 &\text{Assuming 4 cycles of concentration:} \\
 \\
 &\textbf{Bleed Rate} \\
 &= \frac{2.19}{4-1} \\
 &= 0.73 \text{ gpm}
 \end{aligned}$$

Example:

A unit has 100 ton cooling capacity with a compressor EER = 15

$$\begin{aligned}
 &\textbf{Total Heat of Rejection} \\
 &= \text{Unit Capacity in Tons} \times 12000 \times \left(1 + \frac{3.413}{\text{EER}}\right) \\
 &= 100 \times 12000 \times \left(1 + \frac{3.413}{15}\right) \\
 &= 1,473,040 \text{ Btu/hr} \\
 \\
 &\textbf{Total Full Load Heat of Rejection via Evaporation} \\
 &= \text{Total Heat of Rejection} \times \\
 &\quad (1 - \text{fraction of heat rejected by desuperheater}) \\
 &= 1,473,040 \text{ Btu/hr} \times (1 - 0.22) \\
 &= 1,148,971 \text{ Btu/hr}
 \end{aligned}$$

Note that approximately 22% of the total heat of rejection is accomplished with the desuperheater at full load. So, the fraction of heat rejected by the desuperheater (in the equation above) is approximately 0.22 at full load and increases as the ambient dry bulb decreases.



## Energy Recovery Units

Some RZ Series units have been equipped with an energy recovery wheel. AAON provides options for either an aluminum energy recovery wheel or a polymer energy recovery wheel. Follow the instructions for the specific type of energy recovery wheel in your installed equipment.

### **WARNING**

Improper installation, adjustment, alteration, service or maintenance can cause property damage, personal injury or loss of life. Startup and service must be performed by a Factory Trained Service Technician.

## Initial Mechanical Check and Setup

Outdoor units equipped with outside air intake will have an outside air hood. The outside air hood must be opened prior to unit operation.

Outdoor air intake adjustments must be made according to building ventilation, or local code requirements.

After the unit installation is complete, open the cassette access door and determine that the energy wheel rotates freely when turned by hand. Apply power and observe that the wheel rotates. If the wheel does not rotate when power is applied, it may be necessary to readjust the “diameter air seals”.

## Airflow Balancing and Checking

High performance systems commonly have complex air distribution and fan systems. Unqualified personnel must not attempt to adjust fan operation, or air circulation, as all systems have unique operations characteristics. Professional air balance specialists must be employed to establish actual operating conditions, and to configure

the air delivery system for optimal performance.

## Controls

A variety of controls and electrical accessories may be provided with the equipment. Identify the controls on each unit by consulting appropriate submittal, or order documents, and operate according to the control manufacturer’s instructions. If you cannot locate installation, operation, or maintenance information for the specific controls, then contact your sales representative, or the control manufacturer for assistance.

### **WARNING**

Do not alter factory wiring. Deviation from the supplied wiring diagram will void all warranties, and may result in equipment damage or personal injury. Contact the factory with wiring discrepancies.

## *Polymer Energy Recovery Wheel*

This section is provided to assure the polymer energy recovery feature will be properly setup to perform in accordance with the job specifications for your particular application.

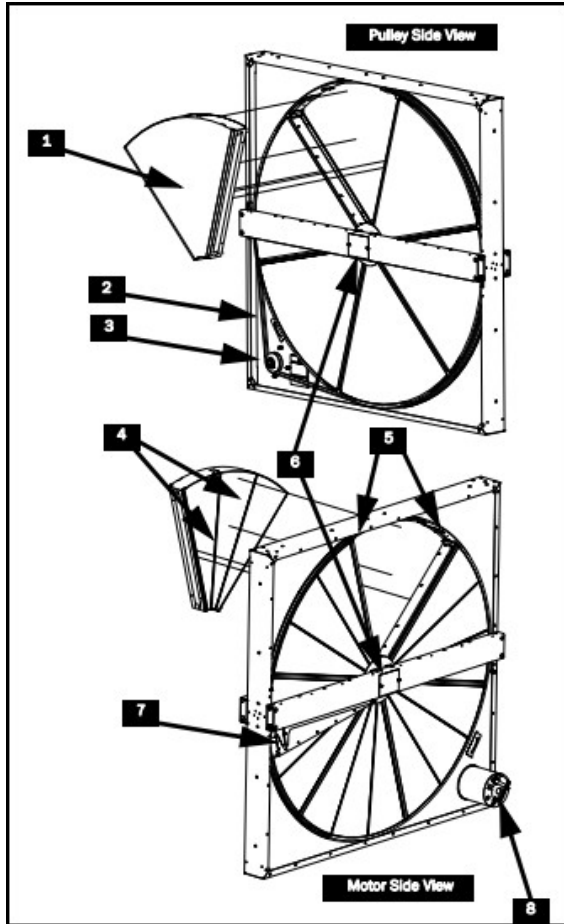

Figure 33 - Polymer Energy Recovery Wheel

1. Removable Segment
2. Permanent Tension Belt
3. Pulley
4. Embedded Segment Stiffeners
5. Segment Retaining Latches
6. Bearing Beam and Bearing Access Cover Plate (Diameter Seals are behind Bearing Beam on both sides)
7. Adjustable Purge
8. Motor

The Energy Recovery Cassette consists of a frame wheel, wheel drive system, and energy transfer segments. Segments are removable for cleaning or replacement. The segments rotate through counter flowing exhaust and outdoor air supply streams where they transfer heat and/or water vapor from the

warm, moist air stream to the cooler and/or drier air stream.

The initial setup and servicing of the energy recovery wheel is very important to maintain proper operation efficiency and building occupant comfort.

Normal maintenance requires periodic inspection of filters, the cassette wheel, drive belts, air seals, wheel drive motor, and its electrical connections.

Wiring diagrams are provided with each motor. When wired according to wiring diagram, motor rotates clockwise when viewed from the shaft/pulley side.

By carefully reviewing the information within this section and following the instructions, the risk of improper operation and/or component damage will be minimized.

It is important that periodic maintenance be performed to help assure trouble free operation.

#### *Aluminum Energy Recovery Wheel*

The aluminum energy recovery wheel is very similar to the polymer wheel except it is a monolith wheel without segments.

#### **Wheel Set Purge Angle**

When installed, the purge angle is factory set to 5 degrees. If a different angle is required, complete the following steps to adjust the purge:

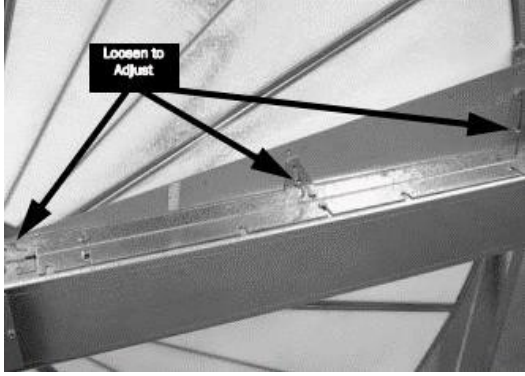

1. Loosen the three purge adjusting screws.
2. Adjust purge sector to the specified angle.

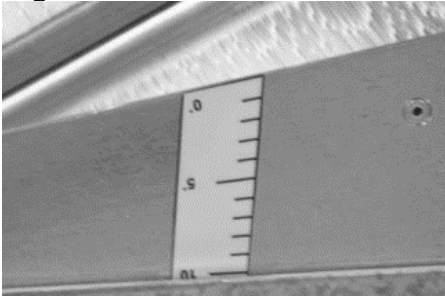

3. Tighten the purge adjusting screws.
4. Turn the wheel by hand clockwise (when viewed from pulley side) to check for interference.

### Wheel Check Purge Seal

If a purge is installed, check for a slight interference fit between the seal and the face of the wheel by sliding a piece of paper (“feeler gauge”) between the seal and the media a multiple locations along the purge seal as you rotate the wheel slowly by hand (clockwise when viewed from the pulley side). Verify that the media slightly grabs the paper during rotation.

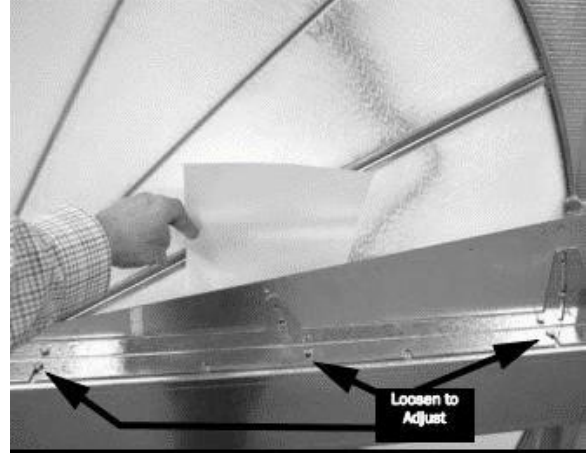

If it is necessary to adjust a purge seal to the face of the wheel, loosen the two or three screws along the bearing beam and adjust to the proper distance from the media surface. Tighten the screws and retest the seal.

### Wheel Air Seal Adjustments

Pile type air seals across both sides of the energy wheel diameter are factory adjusted to provide close clearance between the air seal and wheel. Racking of the unit or cassette during installation, and/or mounting of the unit on a non-level support or in other than the factory orientation can change seal clearances. Tight seals will prevent rotation.

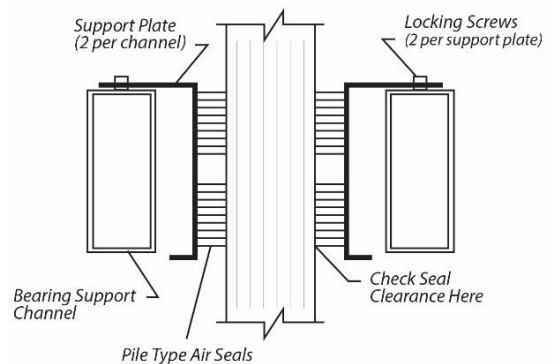

Cross Section of Air Seal Structure

### Wheel to Air Seal Clearance

To check wheel to seal clearance; first disconnect power to the unit, in some units the energy recovery wheel assembly can be pulled out from the cabinet to view the air seals. On larger units, the energy recovery wheel may be accessible inside the walk-in cabinet.

A business card or two pieces of paper can be used as a feeler gauge, (typically each 0.1mm (.004”) thick) by placing it between the face of the wheel and pile seal.

Using the paper, determine if a loose slip fit exist between the pile seal and wheel when the wheel is rotated by hand.

To adjust air seal clearance, loosen all seal plate retaining screws holding the separate seal retaining plates to the bearing support channels and slide the seals plates away from the wheel. Using the paper feeler gauge, readjust and retighten one seal plate at a time to provide slip fit clearance when the wheel is rotated by hand.

Confirm that the wheel rotates freely. Apply power to the unit and confirm rotation. Visually inspect the belt and ensure the belt is tracking near the center of the rim. Verify the wheel speed is approximately 45-50 RPM. Confirm there is no excessive noise such as scraping, brushing, or banging.

### Wheel Installation

Energy recovery cassettes are incorporated within the design of packaged units, packaged air handlers and energy recovery ventilators. In each case, it is recommended that the following considerations be addressed:

### Wheel Accessibility

The cassette and all its operative parts; i.e.: motor, belt, pulley, bearings, seals and

energy transfer segments must be accessible for service and maintenance. This design requires that adequate clearance be provided outside the enclosure. Where cassettes are permanently installed in a cabinet, access to both sides of the cassette must be provided.

### Wheel Orientation & Support

The Energy Recovery Cassette may be mounted in any orientation. However, Care must be taken to make certain that the cassette frame remains flat and the bearing beams are not racked.

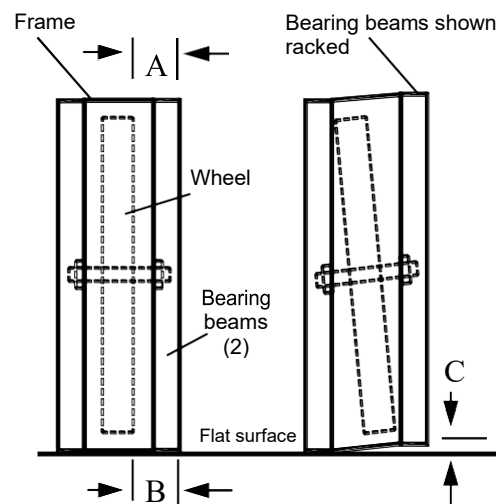

Avoid Racking of Cassette Frame

To verify, make certain that the distance between wheel rim and bearing beam is the same at each end of the bearing beam, to within 6.4 mm (1/4 of an inch) (dimension A & B). This amount of racking can be compensated for by adjusting the diameter seals.

If greater than 6.4 mm (1/4 of an inch) (dimension C), racking must be corrected to ensure that drive belt will not disengage from wheel.

## Wheel Startup Procedure

### CAUTION

Keep hands away from rotating wheel!  
Contact with rotating wheel can cause physical injury.

1. By hand, turn wheel clockwise (as viewed from the pulley side), to verify wheel turns freely through 360° rotation.
2. Before applying power to drive motor, confirm wheel segments are fully engaged in wheel frame and segment retainers are completely fastened. (See Segment Installation Diagram).
3. With hands and objects away from moving parts, activate unit and confirm wheel rotation. Wheel rotates clockwise (as viewed from the pulley side).
4. If wheel has difficulty starting, turn power off and inspect for excessive interference between the wheel surface and each of the four (4) diameter seals. To correct, loosen diameter seal adjusting screws and back adjustable diameter seals away from surface of wheel, apply power to confirm wheel is free to rotate, then re-adjust and tighten hub and diameter seals, as shown in hub seal adjustment diagram.
5. Start and stop wheel several times to confirm seal adjustment and to confirm belt is tracking properly on wheel rim (approximately 1/4" from outer edge of rim).

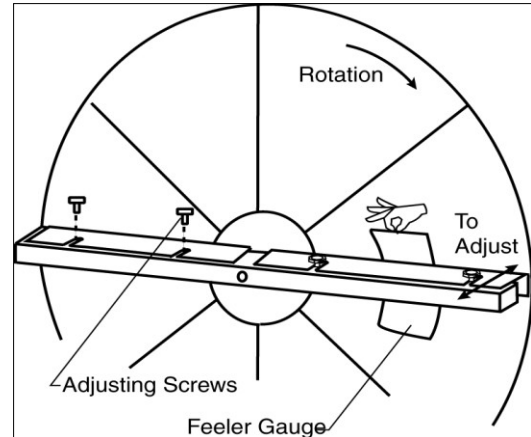

Diameter Seal Adjustment

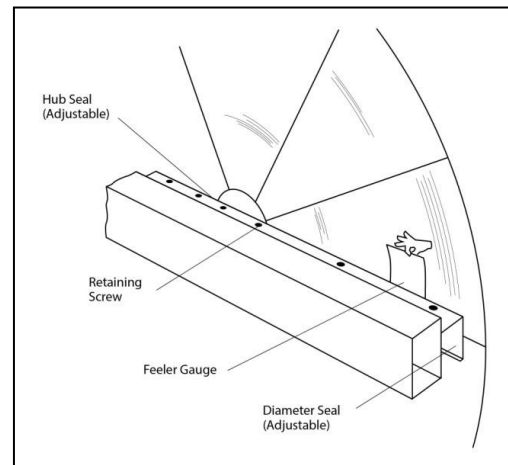

Hub Seal Adjustment

### Wheel Routine Maintenance and Handling

Handle cassettes with care. Lift all cassettes by the bearing support beam. Holes are provided on both sides of the bearing support beams to facilitate rigging as shown in the following illustration.

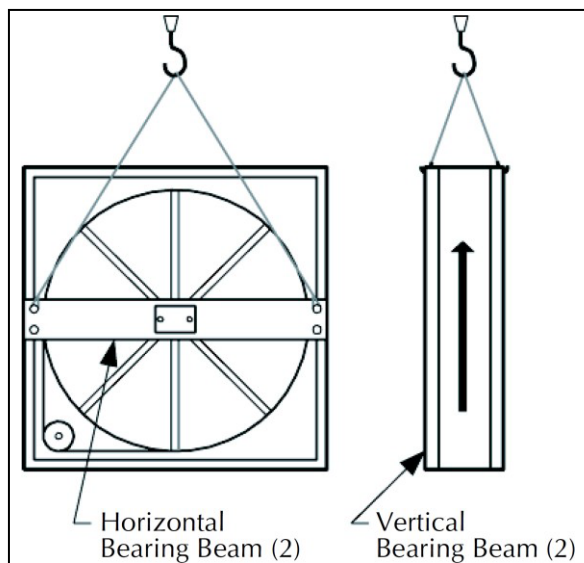

Lifting Hole Locations

Routine maintenance of the Energy Recovery Cassettes includes periodic cleaning of the Energy Recovery Wheel as well as inspection of the Air Seals and Wheel Drive Components as follows:

#### Wheel Air Seals

Four adjustable diameter seals are provided on each cassette to minimize transfer of air between the counter flowing airstreams.

To adjust diameter seals, loosen diameter seal adjusting screws and back seals away from wheel surface. Rotate wheel clockwise until two opposing spokes are hidden behind the bearing support beam. Using a folded piece of paper as a feeler gauge, position paper between the wheel surface and diameter seals.

Adjust seals towards wheel surface until a slight friction on the feeler gauge (paper) is detected when gauge is moved along the length of the spoke. Retighten adjusting screws and recheck clearance with “feeler” gauge.

#### Wheel Drive Components

The wheel drive motor bearings are pre-lubricated and no further lubrication is necessary.

The wheel drive pulley is secured to the drive motor shaft by a combination of either a key or D slot and set screw.

The set screw is secured with removable locktite to prevent loosening. Annually confirm set screw is secure. The wheel drive belt is a urethane stretch belt designed to provide constant tension through the life of the belt. No adjustment is required. Inspect the drive belt annually for proper tracking and tension. A properly tensioned belt will turn the wheel immediately after power is applied with no visible slippage during start-up.

#### Wheel Service

### ! CAUTION

Disconnect electrical power before servicing energy recovery cassette. Always keep hands away from bearing support beam when installing or removing segments. Failure to do so could result in severe injury to fingers or hand.

#### Polymer Wheel Segment Installation & Replacement

An uneven number of segments in the wheel will cause the wheel to accelerate in rotation. Minimize wheel imbalance and unwanted rotation during service by installing or removing opposing segments for even weight distribution. Failure to maintain control of the wheel rotation while removing or installing all segments could cause severe injury to fingers or hands. Always close and secure segment retaining latches before rotating wheel.

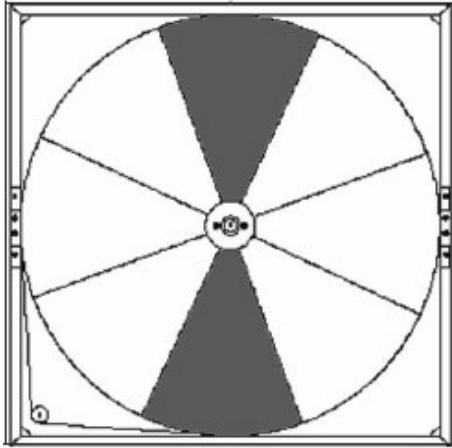
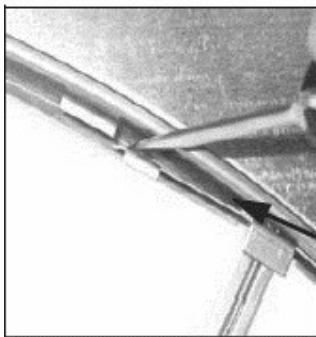
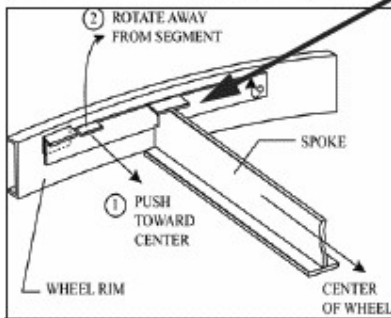

Figure 34 - Polymer Wheel Segment Removal Pattern

Wheel segments are secured to the wheel frame by a Segment Retainer which pivots on the wheel rim and is held in place by a Segment Retaining Latches.



Retaining Latch



Segment Retainer

To install wheel segments follow the steps below. Reverse procedure for segment removal.

1. Disconnect power from the wheel.
2. Gain access to the wheel and slide wheel frame out of cabinet.
3. Unlock two segment retainers (one on each side of the selected segment opening).
4. With the embedded stiffener facing the motor side, insert the nose of the segment between the hub plates.

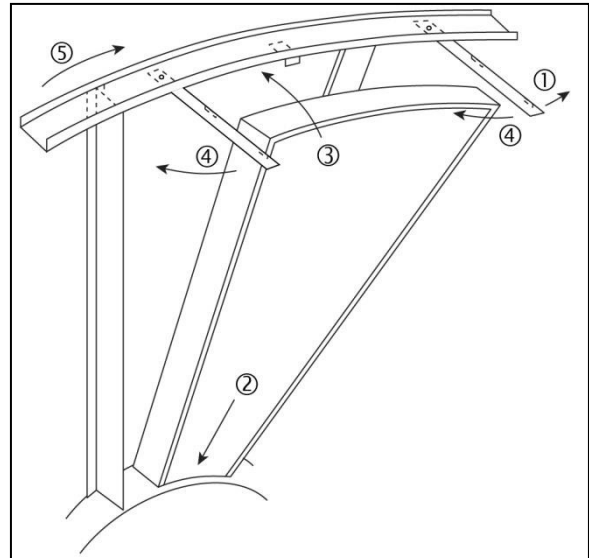

Segment Installation

5. Holding segment by the two outer corners, press the segment towards the center of the wheel and inwards against the spoke flanges. If hand pressure does not fully seat the segment, insert the flat tip of a screw driver between the wheel rim and outer corners of the segment and apply downward force while guiding the segment into place.
6. Close and latch each Segment Retainer under Segment Retaining Catch.
7. Slowly rotate the wheel 180°. Install the second segment opposite the first for counterbalance. Rotate the two installed segments 90° to balance the wheel while the third segment is installed. Rotate the wheel 180° again to install the fourth segment opposite the third. Repeat this sequence with the remaining four segments.

## Wheel Drive Motor and Pulley Replacement

1. Disconnect power to wheel drive motor.
2. Remove belt from pulley and position temporarily around wheel rim.
3. Loosen set screw in wheel drive pulley using a hex head wrench and remove pulley from motor drive shaft.
4. While supporting weight of drive motor in one hand, loosen and remove (4) mounting bolts.
5. Install replacement motor with hardware kit supplied.
6. Install pulley to dimension as shown and secure set screw to drive shaft.
7. Stretch belt over pulley and engage in groove.
8. Follow start-up procedure.

## Wheel Belt Replacement

1. Obtain access to the pulley side bearing access plate if bearing access plates are provided. Remove two bearing access plate retaining screws and the access plate.
2. Using hexagonal wrench, loosen set screw in bearing locking collar. Using light hammer and drift (in drift pin hole) tap collar in the direction of wheel rotation to unlock collar. Remove collar.
3. Using socket wrench with extension, remove two nuts which secure bearing housing to the bearing support beam. Slide bearing from shaft. If not removable by hand, use bearing puller.
4. Form a small loop of belt and pass it through the hole in the bearing support beam. Grasp the belt at the wheel hub and pull the entire belt down.

**Note:** Slight hand pressure against wheel rim will lift weight of wheel from inner race of bearing to assist bearing removal and installation.



## CAUTION

Protect hands and belt from possible sharp edges of hole in Bearing Support Beam.

5. Loop the trailing end of the belt over the shaft (belt is partially through the opening).
6. Reinstall the bearing onto the wheel shaft, being careful to engage the two locating pins into the holes in the bearing support beam. Secure the bearing with two self-locking nuts.
7. Install the belts around the wheel and pulley according to the instructions provided with the belt.
8. Reinstall diameter seals or hub seal and tighten retaining screws. Rotate wheel in clockwise direction to determine that wheel rotates freely with slight drag on seals.
9. Reinstall bearing locking collar. Rotate collar by hand in the direction the wheel rotates (see label provided on each cassette for wheel rotation).
10. Lock in position by tapping drift pin hole with hammer and drift. Secure in position by tightening set screw.
11. Reinstall Bearing Access Cover.
12. Apply power to wheel and ensure that the wheel rotates freely without interference.

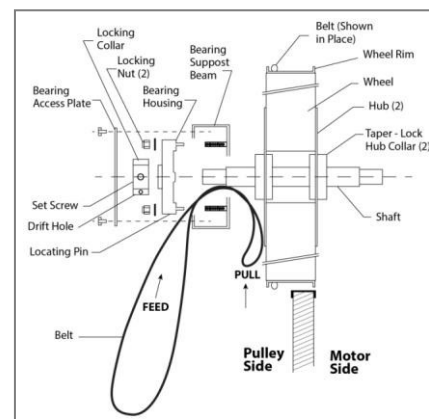

Belt Replacement



*Energy Recovery Wheel General Cleaning*  
 Routine maintenance of the Energy Recovery Wheel includes periodic cleaning of the Energy Recovery Wheel as well as inspection of the Air Seals and Wheel Drive Components.

Cleaning the energy transfer media will help maintain optimal performance. The frequency of cleaning is largely dependent on the application and air quality. Use ASHRAE’s Classes of Air categories, to create a routine cleaning schedule.

Class 1 air has low contaminant concentration with inoffensive odor and sensory irritation intensity.

Class 2 air has moderate contaminant concentration, with mildly offensive odors or sensory-irritation intensity.

Class 3 air has significant contaminant concentration and significant offensive odor or sensory-irritation intensity.

Class 4 air has highly objectionable fumes or gases and potentially contains dangerous particles, bio-aerosols, or gases at a concentration high enough to be considered harmful, not suitable for recirculation or transfer to any other space.

Table 27 - Energy Recovery Wheel Cleaning Frequency

Class of Air	Examples	Cleaning Frequency
Class 1 Clean Air	<ul style="list-style-type: none"> <li>• Offices</li> <li>• Classrooms</li> <li>• Assembly rooms</li> <li>• Churches</li> </ul>	Every 8-10 years
Class 2 Moderately Clean Air	<ul style="list-style-type: none"> <li>• Restrooms</li> <li>• Swimming pools</li> <li>• Dining rooms</li> <li>• Locker rooms</li> <li>• Warehouse</li> <li>• Dorms</li> </ul>	Every 4-6 years
Class 3 Dirty Air	<ul style="list-style-type: none"> <li>• Kitchens</li> <li>• Dry cleaners</li> <li>• Beauty salons</li> <li>• Laboratories</li> <li>• Pet shops</li> </ul>	Every 1-2 years
Class 4 Contaminated Air	<ul style="list-style-type: none"> <li>• Paint spray booths</li> <li>• Laboratory fume exhaust</li> <li>• Kitchen grease exhaust</li> </ul>	Do not use in this application

 **CAUTION**

Disconnect electrical power before servicing energy recovery cassette. Always keep hands away from bearing support beam when installing or removing segments. Failure to do so could result in severe injury to fingers or hand.

The need for periodic cleaning of the energy recovery wheel will be a function of operating schedule, climate and contaminants in the indoor air being exhausted and the outdoor air being supplied to the building.

The energy recovery wheel is “self-cleaning” with respect to dry particles due to its laminar flow characteristics. Smaller particles pass through; larger particles land on the surface and are blown clear as the flow direction is reversed. Any material that builds up on the face of the wheel can be removed with a brush or vacuum. The primary need for cleaning is to remove oil based aerosols that have condensed on energy transfer surfaces. A characteristic of all dry desiccants, such films can close off micron sized pores at the surface of the desiccant material, reducing the efficiency by which the desiccant can adsorb and desorb moisture and also build up so as to reduce airflow.

In a reasonably clean indoor environment such as a school or office building, measurable reductions of airflow or loss of sensible (temperature) effectiveness may not occur for several years. Measurable changes in latent energy (water vapor) transfer can occur in shorter periods of time in applications such as moderate occupant smoking or cooking facilities. In applications experiencing unusually high levels of occupant smoking or oil based aerosols such as industrial applications involving the

ventilation of machine shop areas for example, annual washing of energy transfer may be necessary to maintain latent transfer efficiency. Proper cleaning of the energy recovery wheel will restore latent effectiveness to near original performance.

**Aluminum Wheel Cleaning**

See general energy recovering cleaning section for how often to clean.

To clean, gain access to the aluminum energy recovery wheel then use the following methods:

- Use a brush or vacuum cleaner to remove small foreign materials.
- Use compressed air at a distance of at least 2 ft from the wheel. Too much pressure can easily damage the aluminum media.
- First remove the energy recovery wheel from the unit. Then use water at a distance of at least 2 ft from the wheel. Do not use detergents. Keep temperature below 77°F. Tightly cover all electric parts and bearings while used pressurized water. Remove excess water before reinstalling the wheel.

**Polymer Wheel Cleaning**

To clean, gain access to the energy recovery wheel and remove segments. Brush foreign material from the face of the wheel. Wash the segments or small wheels in a 5% solution of non-acid based coil cleaner or alkaline detergent and warm water.

 **CAUTION**

Do not use acid based cleaners, aromatic solvents, steam or temperatures in excess of 76.7°C (170°F); damage to the wheel may occur!

Soak in the solution until grease and tar deposits are loosened (Note: some staining of the desiccant may remain and is not harmful to performance). Before removing, rapidly run finger across surface of segment to separate polymer strips for better cleaning action. Rinse dirty solution from segment and remove excess water before reinstalling in wheel.

*Energy Recovery Wheel Defrost Timer*

*Setting*

Set Mode to D

T1 is the on time

- Set T1 range to 10m (10 minutes)
- The scale shows 0-6 on the dial
- Set T1 dial to 3 which equals 30 minutes of run time

T2 is the off time

- Set T2 range to 1m (1 minute)
- The scale shows 0-6 on the dial
- Set T2 dial to 2 which equals 2 minutes of off time

Adjust temperature dial to set the point at which any temperature below will activate the defrost timer. Recommended setting is 1.7°C (35°F).

Once the OA Temperature goes below the setpoint, the wheel timer will stop for 2 minutes and run for 30 minutes and will continue to cycle at this rate as long as OA Temperature is below setpoint. If more off time is required to defrost the wheel, increase the T2 Knob time to a greater off time than 2 minutes.



Figure 35 - Defrost Timer

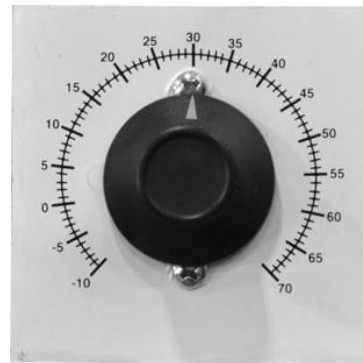

Figure 36- Temperature Dial

### Gas or Electric Heating

The unit is designed to heat a given airflow. If this amount of air is greatly reduced, approximately 1/3 during the heating season, the gas heat exchanger or electric heating coil may overheat, and may turn the burner or heater off entirely by action of the safety high temperature limit devices which are factory mounted at the heat exchanger and supply blower areas.

Adjust airflow after installation to obtain an air temperature rise within the range specified on the unit rating plate at the required external static pressure.

Should overheating occur with a gas heat exchanger, or the gas supply fail to shut off, shut off the manual gas valve to the furnace before shutting off the electrical supply.

Prolonged overheating of the heat exchanger will shorten its life.

If unit has not been selected as a 100% outside air unit (makeup air unit) the return air duct must be sealed to the unit and the return air temperature must be maintained between 12.8°C (55°F) and 26.7°C (80°F).

Table 28 - RZ 45-140 ton Electric Heating Capacities

Model Option B3	Electric Heat Capacity	
	kW (208V)	kW (230V, 380V 460V, 575V)
1 = Heat 1	60.1	80
2 = Heat 2	90.1	120
3 = Heat 3	120.1	160
4 = Heat 4	150.2	200
5 = Heat 5	180.2	240

Table 29- RZ 145-240 ton Electric Heating Capacities

Model Option B3	Electric Heat Capacity	
	kW (208V)	kW (230V, 380V 460V, 575V)
1 = Heat 1	60.1	80
2 = Heat 2	90.1	120
3 = Heat 3	120.1	160
4 = Heat 4	180.2	240

Table 30 - RZ 45-140 ton Gas Heating Capacities

Model Option B3	Gas Heat Capacity	
	Input (MBH)	Output (MBH)
1 = Heat 1	540	437
2 = Heat 2	810	656
3 = Heat 3	1080	875
4 = Heat 4	1350	1094
5 = Heat 5	1620	1312
6 = Heat 6	2100	1701
7 = Heat 7	2580	2090
8 = Heat 8	3060	2479

Table 31 - RZ 145-240 ton Gas Heating

Model Option B3	Gas Heat Capacity	
	Input (MBH)	Output (MBH)
1 = Heat 1	800	648
2 = Heat 2	1200	972
3 = Heat 3	1600	1296
4 = Heat 4	2000	1620
5 = Heat 5	2400	1944
6 = Heat 6	3100	2511
7 = Heat 7	3800	3078
8 = Heat 8	4500	3645

## Gas Heating

 <b>WARNING</b>
<b>FOR YOUR SAFETY</b> Read the entire gas heating installation section of this manual before beginning installation of the gas heating section.  If you do not follow these instructions exactly, a fire or explosion may result causing property damage, personal injury or loss of life.

Verify the unit nameplate agrees with the proper gas supply type and amount.

Table 32- Min and Max Gas Pressures (Metric)

Min and Max Inlet Gas Pressure (inH2O)		
Gas Type	Min Pressure	Max pressure
Natural Gas	6	10.5
Propane	11	13

Table 33- Min and Max Gas Pressures (Imperial)

Min and Max Inlet Gas Pressure (mmHg)		
Gas Type	Min Pressure	Max pressure
Natural Gas	11.2	19.6
Propane	20.6	24.3

A field provided 3.2mm (1/8") NPT pressure tap is required to be installed in the piping just upstream of the shutoff valve for test gage connection to allow checking of the gas supply pressure at the unit.

A factory installed pressure tap on the outlet end of the gas valve can be used to verify a manifold pressure of 6.5 mmHg (3.5" w.c.) for natural gas, or 19.6 mmHg (10.5" w.c.) for propane.

Gas piping shall be installed in accordance with local codes, or in the absence of local codes, installation shall conform to the current (United States) National Fuel Gas Code ANSI-Z223.1/NFPA 54 or the current

(Canada) National Fuel & Propane Installation Code CSA B149.1 or B149.2.

After verifying gas inlet pressure and manifold pressure the service technician shall time the gas flow rate through the gas meter with a stopwatch to verify the gas input rate.

Unit nameplate input rate value has been calculated at the altitude where the unit was shipped. Above 609.6 m (2,000 ft)., the input rate is adjusted 4% for every 304.8 m (1,000 ft).

Table 34 - RZ 45-140 ton Unit Gas Piping Connections

RZ Small Gas Input (MBH)	Connections	
	Quantity	Size
540	1	2"
810	1	
1080	1	
1350	1	
1620	1	
2100	1	3"
2580	1	
3060	1	

Note: 2" = 51 mm, 3" = 76 mm

Table 35 - RZ 145-240 ton Unit Gas Piping Connections

RZ Medium Gas Input (MBH)	Connections	
	Quantity	Size
800	1	2-1/2"
1200	1	
1600	1	
2000	1	
2400	1	
3100	1	3"
3800	1	
4500	1	

Note: 2 1/2" = 63.5 mm, 3" = 76

See unit nameplate for unit gas heating capacities or the Unit Rating Sheet, which can be obtained from the AAON sales representative.

Table 36 – **(Metric)** Natural Gas Maximum Piping Capacities (m<sup>3</sup>/hr)  
 - Specific Gravity = 0.6, Supply Pressure ≤ 3.5 kpa, Pressure Drop = 0.93 mmHg

Pipe Size (mm)	Length of Pipe				
	6.1 m	15.2 m	30.4 m	45.6 m	60.8 m
31.75	26.9	16.4	11.3	9.2	7.9
38.10	41.3	25.5	17.6	14.2	12.2
50.80	77.9	47.6	32.6	26.9	22.7
63.50	123.2	75.0	52.4	42.5	36.2
76.20	220.3	134.2	92.3	73.9	63.4
101.60	450.2	273.5	188.0	150.9	129.1

Table 37 – **(Imperial)** Natural Gas Maximum Piping Capacities (ft<sup>3</sup>/hr)  
 - Specific Gravity = 0.6, Supply Pressure ≤ 0.5 psi, Pressure Drop = 0.5" w.c.

Pipe Size	Length of Pipe				
	20 ft	50 ft.	100 ft.	150 ft.	200 ft.
1-1/4"	950	580	400	325	280
1-1/2"	1460	900	620	500	430
2"	2750	1680	1150	950	800
2-1/2"	4350	2650	1850	1500	1280
3"	7780	4740	3260	2610	2240
4"	15900	9660	6640	5330	4560

Table 38 – **(Metric)** Propane (kW) Maximum Piping Capacities  
 Specific Gravity = 1.52, Supply Pressure = 2.34 kpa., Pressure Drop, 0.93 mmHg

Pipe Size (mm)	Length of Pipe				
	6.1 m	15.2 m	30.4 m	45.6 m	60.8 m
31.75	438.1	266.7	184.6	149.5	127.5
38.10	672.6	414.7	285.7	230.1	194.9
50.80	1269.0	775.2	530.5	438.1	375.1
63.50	2064.7	1271.9	876.3	706.3	609.6
76.20	3666.3	2258.1	1554.7	1254.3	1059.5
101.60	7479.2	4610.0	3174.0	2560.0	2162.9

Table 39 – **(Imperial)** Propane (kBtu/hr) Maximum Piping Capacities  
 Specific Gravity = 1.52, Supply Pressure = 0.34 psi, Pressure Drop, 0.5" w.c.

Pipe Size	Length of Pipe				
	20 ft	50 ft.	100 ft.	150 ft.	200 ft.
1-1/4"	1495	910	630	510	435
1-1/2"	2295	1415	975	785	665
2"	4330	2645	1810	1495	1280
2-1/2"	7045	4340	2990	2410	2080
3"	12510	7705	5305	4280	3615
4"	25520	15730	10830	8735	7380

**! CAUTION**

Heater must be disconnected from the gas supply piping during pressure testing of the supply piping system with pressures in excess of 3.45 kpa (½ psi). Gas valves can be damaged if subjected to more than 3.45 kpa (½ psi).

Do not use gas piping smaller than unit gas connections. Natural gas pipe that runs longer than 6.1 meters (20 feet) and propane gas pipe that runs longer than 15.2 meters (50 feet) may require a larger supply pipe than the unit connection size. Some utility companies may also require pipe sizes larger than the minimum sizes listed.

*Piping Sizing Example (Imperial units)*

A 100 ft pipe run is needed for a 1710 MBH natural gas heater. The natural gas has a rating of 1000 BTU/ft<sup>3</sup> and a specific gravity of 0.6 (Obtain these values from the local gas supplier.)

$$1710 \text{ MBH} \times \frac{\text{ft}^3}{1000 \text{ BTU}} = 1710 \text{ ft}^3/\text{hr}$$

From Table 34 at 100 ft and 1710 ft<sup>3</sup>/hr the required minimum pipe size is 2-1/2”.

A 100 ft pipe run is needed for a 800 MBH propane gas heater. 800 MBH = 800 kBtu/hr, at 100 ft and 800 kBtu/hr the required minimum pipe size is 1-1/2”.

*Gas Pressure Regulator & Overpressure Protection Device*

A gas pressure regulator shall be installed if natural gas supply pressure to the unit is greater than 10.5” w.c. and less than 2 psi (55.4” w.c.) and if propane gas supply pressure is greater than 13” w.c. and less than 2 psi (55.4” w.c.). Regulators shall comply with the latest edition of the Standard for Line Pressure Regulators, ANSI Z21.80/CSA 6.22.

Both a gas pressure regulator and overpressure protection device (OPD) shall be installed if gas supply pressure to the unit is greater than 2 psi (55.4" w.c.) and less than 5 psi (138.4" w.c.), in compliance with ANSI Z21.80/CSA 6.22. For proper heater operation, pressure to the regulator SHALL NOT be greater than 5 psi (138.4" w.c.).

*Piping Supports*

Gas supply piping shall be supported directly at the connection to the unit and at intervals listed in the following table with metal straps, blocks, or hooks. Piping shall not be strained or bent.

Table 40 - Piping Support Intervals (Metric)

Pipe Size (mm)	Support Intervals
12.7 to 19.1	Every 1.8 m
19.1 to 25.4	Every 2.4 m
44.5 or Larger (Horizontal)	Every 3 m
31.8 or Larger	Every Floor

Table 41 - Piping Support Intervals (Imperial)

Pipe Size	Support Intervals
1/2" to 3/4"	Every 6 ft
3/4" to 1"	Every 8 ft
1-3/4" or Larger (Horizontal)	Every 10 ft
1-1/4" or Larger (Vertical)	Every Floor

*Additional Gas Piping Considerations*

Local codes will usually require a field provided and installed manual main shutoff valve and union external the unit. Main shutoff valve shall be labeled. A field provided 1/8" NPT pressure tap is required to be installed in the piping just upstream of the shutoff valve for test gage connection to allow checking of the gas supply pressure at the unit. A drip leg shall be installed near the unit connection to trap sediment and condensate. Pipe joint compounds used on all gas piping connections shall be resistant to

liquid petroleum gases. If flexible gas piping to the unit, or in the unit, must be replaced connectors cannot be reused, only new connectors may be used.

Heat exchanger comes equipped with a condensate drain which shall be plumbed to the appropriate drain according to the (United States) National Fuel Gas Code ANSI-Z223.1/NFPA 54 or the current (Canada) National Fuel & Propane Installation Code CSA B149.1 or B149.2, the International Building Code, and any applicable local and regional codes and regulations.

The condensate drain connection is located next to the gas entry location. Each gas heater has a silicone condensate drain connected to it. The drains on each side of the unit run into a common drain line which exits the unit near the bottom of the heat access doors.

AAON gas fired heat exchangers are designed to be non-condensing. These heat exchangers are mounted downstream of the cooling coils. During the cooling season the ambient air inside the heat exchanger tubes can condense due to cold air being blown over the outside of the tubes. The amount of condensation will vary depending on the ambient air temperature and humidity as well as air temperature over the tubes. This condensation can be drained onto the roof or into any waste drain.

Typically during the heating season the heat exchanger will not make any condensation. However, short-cycling of the heater can prevent the flue gases from reaching temperatures above dew point (about 54.4°C [130°F]) which can cause condensation in the heat exchanger.

Staged or modulated heat exchangers may produce condensate depending on the firing rate, ambient air temperature and humidity as well as the percentage and temperature of outside air being introduced to the unit. This



condensate is generally between a 2.9 and 4 pH level.

Condensation made in the heat exchanger during the heating mode may need to be managed and not just drained onto the roof depending on national and local code requirements and the application of the final user. This condensate can stain the roof and it can cause rust in some cases on metal roofs. It is the responsibility of the end user or contractor to determine if the condensate will damage the roofing material.

Below freezing ambient air temperatures during the heating mode can freeze any condensation made in the drain lines. Smaller amounts of condensation may not cause any issues but for larger amounts of condensate and low ambient air temperatures (below freezing for multiple consecutive days) the internal and external drain lines for the unit will need to be heat traced to prevent freezing. Heat traced internal drain lines are required and a factory provided standard feature on the condensate drain with the high turndown modulating gas option.

A condensate neutralizer vessel and connecting tubing can be added to the equipment if required. For below freezing ambient temperature applications the neutralizer, connecting tubing and drain lines will require heat tracing to prevent condensate freezing. These components are the responsibility of the installer.

 **DANGER**

Do not use open flame or other source of ignition for leak testing. Fire or explosion could result causing property damage, personal injury, or death.

 **DANGER**

**LEAK CHECK GAS PIPE**

The gas pipe in the unit shall be checked for leaks before operation and startup. Unit must not be placed in operation until a leak check has been conducted for all gas piping connections. All connections shall be checked for leaks annually after installation. Gas leaks could result in fire, explosion, or other hazardous situations.

 **CAUTION**

Some soaps used for leak detection can be corrosive to certain metals. Rinse piping thoroughly after leak test has been completed.



Figure 37 - Gas Heater Rain Hood

#### Leak Testing

All components of gas supply system, including manual shut off valves and the piping in the interior of the unit, shall be leak tested with a soap solution before operating the appliance and at least on an annual basis thereafter.

All gas fired heat exchangers are completely tested at the factory before shipment. This will remove nearly all of the oils that have been used in the manufacturing process. However, trace amounts may remain. When performing the initial startup at the jobsite, people or any other living animals that may be sensitive to the residual odors or gases, shall NOT be present in the conditioned space during the startup. In all cases, including the initial factory firing and testing, any of the gases will be under the acceptable level of concentration for human occupancy.

Installation of the gas heaters shall be adjusted to obtain an air temperature rise within the range specified on the rating plate.

#### Rain Hoods

Gas heating units include factory provided exterior rain hoods. The hoods are fastened in place with sheet metal screws. Higher heating capacity units will have two banks of gas fired heat exchangers (see *Figure 37*). All of the provided hoods shall be installed after the unit is set in place.



Figure 38 - Gas Heater Rain Hood Screws

#### **! WARNING**

When locating gas fired units, install the unit so that the flue discharge vents are located at least 120 inches away from any opening through which combustion products could enter the building.

#### **! WARNING**

Those sensitive to odors or gases from trace amounts of residual oils shall NOT be present in the conditioned space during the startup of a gas fired installation.

#### **! WARNING**

All exterior heater rain hoods shall be in place before the gas fired heater is initially started. Improper and dangerous operating conditions will otherwise result.

## Gas Heater Operating Instructions

### FOR YOUR SAFETY READ BEFORE OPERATING

**WARNING: IF YOU DO NOT FOLLOW THESE INSTRUCTIONS EXACTLY, A FIRE OR EXPLOSION MAY RESULT CAUSING PROPERTY DAMAGE, PERSONAL INJURY OR LOSS OF LIFE.**

- A. This appliance does not have a pilot. It is equipped with an ignition device which automatically lights the burner. Do **not** try to light the burner by hand.
- B. **BEFORE OPERATING** smell all around the appliance area for gas. Be sure to smell next to the floor because some gas is heavier than air and will settle on the floor.
- WHAT TO DO IF YOU SMELL GAS**
- Do not try to light any appliance.
  - Do not touch any electric switch; do not use any phone in your building.
  - Immediately call your gas supplier from a neighbor's phone. Follow the gas supplier's instructions.
  - If you cannot reach your gas supplier, call the fire department.
- C. Use only your hand to move the on/off switch.
- D. Do not use this appliance if any part has been under water. Immediately call a qualified service technician to inspect the appliance and to replace any part of the control system and any gas control which has been under water.

### OPERATING INSTRUCTIONS

1. STOP! Read the safety information above this label.
2. Set the thermostat to lowest setting.
3. Turn off all electric power to the appliance.
4. This appliance is equipped with an ignition device which automatically lights the burner. Do **not** try to light the burner by hand.
5. Remove control access panel.
6. Move the on/off switch to the "OFF" position.
7. WAIT five (5) minutes to clear out any gas. If you then smell gas, STOP! Follow "B" in the safety information above on this label. If you don't smell gas, go to next step.
8. Move the on/off switch to the "ON" position.
9. Replace control access panel.
10. Turn on all electric power to the appliance.
11. Set thermostat to desired setting.
12. If the appliance will not operate, follow the instructions "To Turn Off Gas To Appliance" and call your service technician or gas supplier.

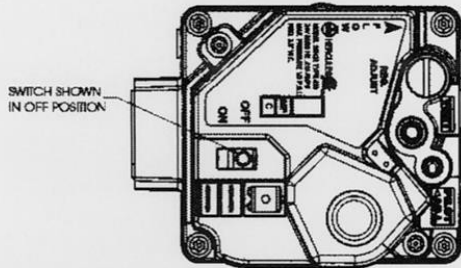

### TO TURN OFF GAS TO APPLIANCE

1. Set the thermostat to lowest setting.
2. Turn off all electric power to the appliance if service is to be performed.
3. Remove control access panel.
4. Move the on/off switch to the "OFF" position.
5. Replace control access panel.

**! WARNING**

Once a year, before the unit is in operation for the heating season, a qualified service technician shall inspect all flue product carrying areas of the furnace and main burners for continued safe operation.

**! DANGER**

**LEAK CHECK GAS PIPE**

The gas pipe in the unit shall be checked for leaks before operation and startup. Unit must not be placed in operation until a leak check has been conducted for all gas piping connections. All connections shall be checked for leaks annually after installation. Gas leaks could result in fire, explosion, or other hazardous situations.

Make sure all gas supply lines have been purged of air before turning on the electrical power switch. Turn the gas valve to the on position (see startup instructions). Turn the main electrical power on and set the controls to the heating mode of operation.

The combustion ventilation motor will enable. The control will automatically supply power to the igniter and the gas valve after the heating call is made.

The flame sensing probe detects the presence of the flame. Should no flame be detected in 10 seconds, the ignition system will recycle. If no flame is detected after 3 tries, ignition system will lockout.

Remove the call for heating. The main gas valves should be extinguished.

The supply fans are controlled by the ignition system. In the fan “Auto” mode the fans come on 45 seconds after the flame is proven and go off 120 seconds after the cooling call is removed.

Furnace combustion ventilation air and flue openings shall be checked annually for debris and obstructions. If vent extensions are used they shall meet category III requirements.

This appliance contains a wire screen at the vent outlet. Each heating season, prior to placing the appliance in heat mode maintenance check that no debris or foreign matter has accumulated in the vent outlet. A good practice is to check for debris each time the air filters are changed.

In the event the vent outlet becomes blocked do not attempt to start the appliance in heat mode until the entire vent opening is cleared.

In the event the unit shut down because the vent was blocked a qualified technician or service agency shall monitor the unit prior to re-starting.

The gas burner and heat exchanger should never require cleaning. If cleaning is necessary, this indicates faulty operation of the unit. Cleaning shall only be done by a qualified service agency and only after consultation with an AAON service representative.

If induced draft blower/motor assembly has to be replaced, care shall be taken to provide an airtight seal between the blower housing and the burner box.

### Gas Heat Exchanger Removal

#### **! WARNING**

Electric shock hazard. Shut off all electrical power to the unit to avoid shock hazard or injury from rotating parts.

#### **! DANGER**

##### **LEAK CHECK GAS PIPE**

The gas pipe in the unit shall be checked for leaks before operation and startup. Unit must not be placed in operation until a leak check has been conducted for all gas piping connections. All connections shall be checked for leaks annually after installation. Gas leaks could result in fire, explosion, or other hazardous situations.

#### *Removal*

Verify that the unit power has been switched off.

Disconnect all wiring on the heat exchanger.

Disconnect flex gas lines and pull out of the way.

Remove screws around the perimeter of the heat exchanger face plate that connect it to the unit. Only the outermost screws should be removed.

Pull the heat exchanger straight back and out of the unit. It may be necessary to remove some of the control door jambs.

#### *Reinstallation*

Ensure that the neoprene isolator is installed around the perimeter of the heat exchanger. Insert heat exchanger into opening so that the back of the main plate is against the unit bulkhead.



Figure 39- Gas Heat Exchanger

Attach the heat exchanger to the bulkhead using the holes around the perimeter.

Connect flex gas lines to the piping on the heat exchanger. If flexible gas piping in the unit must be replaced connectors cannot be reused, only new connectors may be used.

Connect wiring per the wiring diagram on the controls compartment door.

Purge gas lines to the gas valves at the unit.

#### **Direct Fired Gas Heating**

Direct fired burners mix gaseous fuel and outside air to fire directly into the unit air stream. Therefore, all available heat (minus the heat of vaporization) is released directly into the air stream. Optimal performance demands that air velocities be uniform across the entire burner. The profile plates around the burner are adjustable to maintain the required velocity. Adequate building relief shall be designed and incorporated into the building. Non-recirculating units (100% outside air) shall not be connected to any form of return duct. The outside air shall be ducted directly outdoors.

*Inlet and Manifold Pressures*

For units with Direct Fire Heat, the minimum inlet gas pressure to the unit is 13.8 kpa (2 psi) and maximum inlet gas pressure to the unit is 34.5 kpa (5 psi). A field provided 3.2 kpa (1/8") NPT pressure tap is required to be installed in the piping just upstream of the shutoff valve for test gage connection to allow checking of the gas supply pressure at the unit.

*Direct Fire Units with Return Air - Recirculating Operating Limits*

Minimum return temperature -40°F  
 Maximum return temperature 35°C (95°F)  
 Maximum discharge temperature 60°C (140°F)  
 Maximum temperature rise limits\*:

RZA-045-140 tons =  
 32.2°C (90°F)

RZA-145-240 tons

- Burner shorter than 5' = 32.2°C (90°F)
- Burner 5' & longer = 37.8°C (100°F)

**! WARNING**

On heaters which recirculate room air, outside ventilation air must be provided in accordance with the information shown on the heater nameplate.

Table 42- Maximum Temperature Rise Setpoint for Return Air Units

Minimum Ventilation Rate (as % of total outside air throughput)	5%	10 %	15%	20%	25%	30%	40%	50%	60%	100%
Maximum Temperature Rise Setpoint (°F)	10	22	35	47	59	72	*See maximum temperature rise limits above			
Maximum Temperature Rise Setpoint (°C)	-12.2	-5.6	1.7	8.3	15.0	22.2				

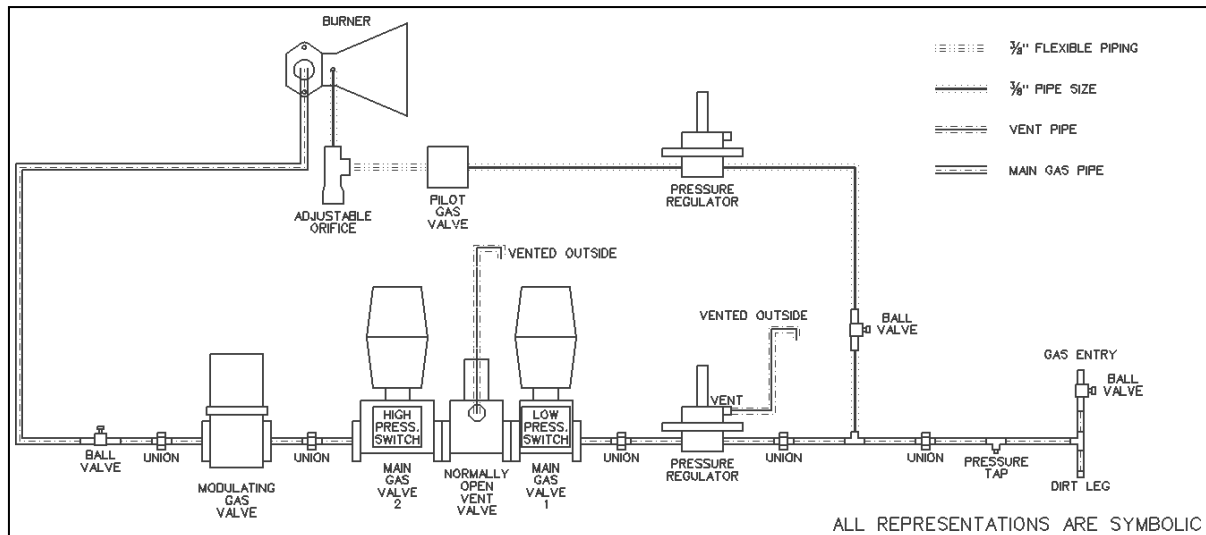

Figure 40- Typical Factory Mutual (FM) Gas Piping Schematic for a Direct Fired Heater

The burner comes with a pilot to ignite the flame and the pilot includes an adjustable orifice. An ignition transformer and spark igniter provide the spark to ignite the pilot and the pilot lights the main burner. The pilot and main burner flames are verified with a flame rod or UV flame supervisor. Capacity is controlled by a modulating gas valve.

#### *Direct Fired Units with Return Air - Purge Sequence of Operations*

If the unit is in an off state or in a full economizer mode state prior to entering heating mode, a purge sequence is necessary.

1. Outside air damper is closed completely so the unit is operating in 100% return air.
2. Supply fan modulating output is set to the heating mode supply fan output as configured for CAV heating.
3. If fan is not already enabled, supply fan is enabled.
4. Waits up to 30 seconds for the supply fan proving switch to engage.
  - a. If supply fan proving switch does not engage within 30 seconds, an airflow alarm will go off.
5. Continues running with outdoor damper closed and supply fan operating for 3 minutes.

#### *Direct Fired Ignition Sequence of Operations*

1. Pre-purge of the burner with fresh air for 30 seconds. Ignition will not proceed if flame is detected.
2. Pre-ignition of the sparker for 2 seconds in air only
3. Open the pilot gas valve for 10 seconds and verify pilot flame detection. Safety shutdown occurs if pilot is not detected by the end of 10 seconds.
4. When pilot flame is proven, the sparker is deactivated, main gas valve 1 and 2 are opened and the vent valve is closed.
5. The pilot valve is deactivated after a 10 second main flame establishing time.

6. The modulating gas valve can modulate to maintain capacity based on 0-10 VDC input to the modulating gas valve controller (the modulating gas valve controller sends a 0-20 VDC signal to the modulating gas valve).

#### *Direct Fired Safeties:*

1. There is an air flow proving switch which is a differential pressure switch that is mounted across the supply blower bulkhead wall. This switch needs 0.93 mmHg (0.5" w.c.) to activate.
2. There is an adjustable air side high pressure switch on the inlet to the burner profile plate. This setting is application specific and the setpoint can be located on the unit nameplate.
3. There is an adjustable air side low pressure switch on the outlet of the burner profile plate. This setting is application specific and the setpoint can be located on the unit nameplate.
4. There are door interlock switches on the air stream access doors upstream and downstream of the burner. These interlock switches will deactivate the heater if the doors are open.
5. There is a main limit switch downstream of the burner. This setting is shown on the unit nameplate.
6. There is an adjustable manual reset high gas pressure switch on Main Gas Valve 2. Set this switch to trip at 125% of the maximum manifold gas pressure as shown on the unit nameplate.
7. There is an adjustable manual reset low gas pressure switch on Main Gas Valve 1. Set this switch to trip at the minimum manifold gas pressure as shown on the unit nameplate.
8. There is an automatic reset valve proving switch located between the main shut off valves. Set this switch at 50% of the incoming gas pressure.

*Direct Fired Initial Start-up Procedure:*

1. Bleed air from main gas line.
2. Verify proper incoming gas pressure.
  - a. Refer to the unit nameplate for determining the minimum gas supply pressure for obtaining the maximum gas capacity for which the heater is specified.
3. Adjust incoming gas pressure with main regulator (on blocking valve actuator) to required gas manifold pressure as shown on unit nameplate.
4. Activate supply fan for heating call.
5. Verify that all dampers in are the correct position before and after activating the heating call.
6. Verify that the supply air, outside air and return air (if applicable) flow rates are correct as ordered.
7. Activate a call for heat.
8. With the main burner hand valve closed, open pilot valve to ignite the pilot. This may take several attempts in order to bleed any air from the line.
9. Verify pilot flame size, color and signal. Adjust the pilot during lighting to a hard, blue flame. Pilot signal shall be between 1.25 VDC and 5 VDC. It is better to be closer to 5 VDC. Adjust pilot pressure as necessary.
10. After the pilot has ignited, open the main burner hand valve to ignite the burner
11. Measure the gas manifold pressure and adjust as necessary
12. Verify that the airside differential pressure across the burner profile plates meets the unit specifications
13. Verify flame length and color. Troubleshoot if the flame has yellow tips. Slight yellow tipping is acceptable with liquid propane.

*Direct Fired First Firing or Restart after Extended Shut-down:*

Before start-up or after an extended period shut down, the integrity of the system shall be

checked by authorized service technician. Check the condition of the mixing plates, burner body drillings, as well as the general mechanical installation of the burner and piping. Check all bolted connections of the burner after the first firing and tighten as necessary.

*Direct Fired General Maintenance*

*Instructions:*

Makeup heat installations shall be maintained and inspected at a minimum of once per season. More frequent maintenance and inspections shall be performed in applications that operate all year. As a minimum the following procedure shall be followed.

1. Completely shut the system down. Lock out the power supply to prevent accidental start-up.
2. Inspect the burners carefully, including the upstream and downstream sides of the mixing plates as well as the burner body face. Any accumulation of scale or foreign material on either side of the mixing plates shall be removed with a wire brush. Visually inspect the holes in the mixing plates to verify that all of the holes are opened without blockage. Clean any carbon build-up present and troubleshoot for cause.
3. Replace or tighten any missing or loose fasteners. Always use zinc plated or stainless metric fasteners.
4. Ensure that all vents to the atmosphere are clean and free from obstruction.
5. Inspect and clean all drip legs in the gas lines.
6. Inspect all electrical components, connections and terminals. Clean and tighten as necessary.
7. Clean ignition electrodes if necessary.
8. Put system back into operation and observe the complete operation of the burners through the full firing range.



There is an observation viewport window in the gas piping compartment.

9. Observe the flame pattern and take any necessary steps to correct any velocity and/or air distribution problems.
10. Test the ignition spark and adjust gap if necessary. Clean any carbon build-up on ignition probes and troubleshoot for cause.
11. Inspect all valves and piping for operation and clean as necessary.
12. Inspect UV sensor observation window. Clean any dust or debris present.

*Inspection and Maintenance of Gas Ports:*

1. Conduct an initial inspection within the first month after commissioning. Visually check the gas ports of new burner assemblies for any piping scale or debris. Use pin vise with drill bit to remove (see below).
2. Annual inspections are normally adequate once the initial piping debris is removed. The operating conditions of the burner will determine how frequently the maintenance is actually required.

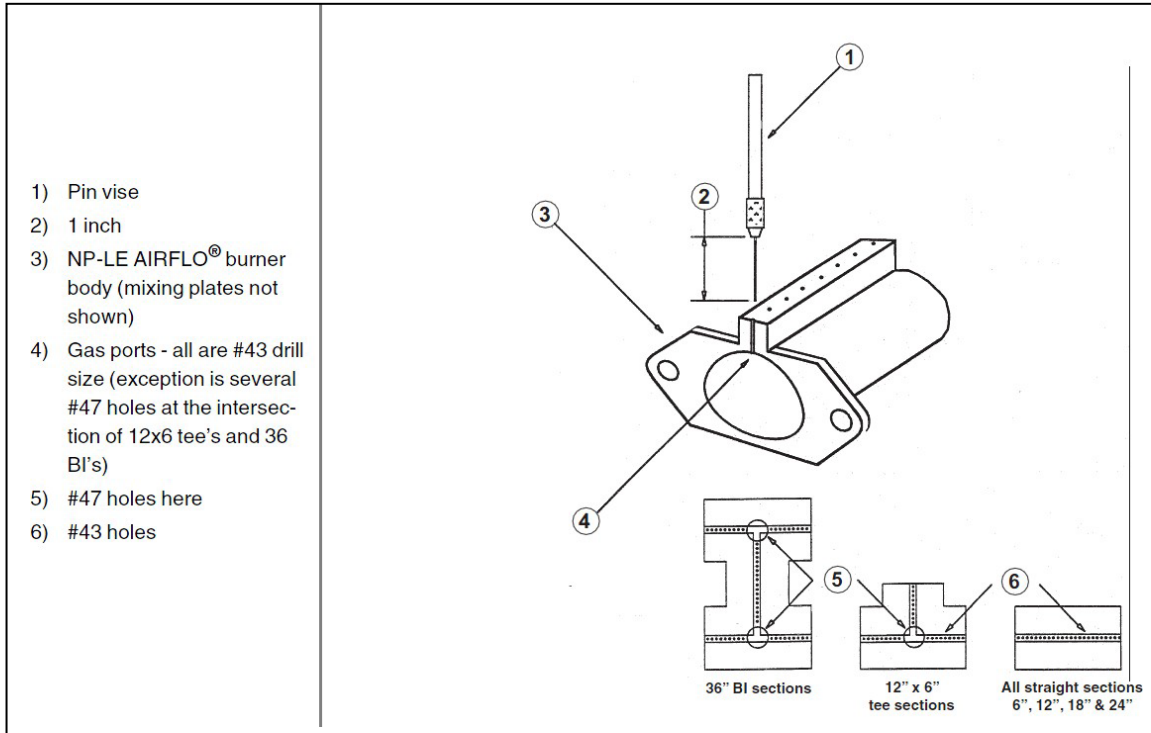

Figure 41 - Removing Piping Scale with Pin Vise

## Phase and Brownout Protection Module



The DPM is a Digital Phase Monitor that monitors line voltages from 200VAC to 240VAC 1 $\phi$  and 200VAC to 600VAC 3 $\phi$ . The DPM is 50/60 Hz self-sensing. DPM must be wired according to unit specific wiring diagram include in the control compartment

When the DPM is connected to the line voltage, it will monitor the line and if everything is within the setup parameters, the output contacts will be activated. If the line voltages fall outside the setup parameters, the output relay will be de-energized after the trip delay.

Once the line voltages recover, the DPM will re-energize the output relay after the restart time delay. All settings and the last 4 faults are retained, even if there is a complete loss of power.

### DPM Setup Procedure

With the supply voltage active to the module, you can setup all of the DPM's settings without the line voltage connected.

To change the setpoint parameters use the right arrow key to advance forward through

the setpoint parameters and the left arrow to backup if needed. When each parameter is displayed use the up/down keys to change and set the parameter.

After adjustments are made or if no adjustments are made it will take 2 to 4 minutes before the DPM energizes the output relay unless there is an out of tolerance issue with the incoming line voltage.

### Recommended Default Set-up

Line Voltage	460VAC, 3 $\phi$
Over & Undervoltage	$\pm$ 10%
Trip Time Delay	5 Seconds
Re-Start Time Delay	2 Minutes
Phase Imbalance	5%



Phase and brownout module may be this type on some products (as seen in the above picture). No setup is needed with this module version, other than checking that the voltage jumper voltage matches the unit voltage

## Screens

### Manufacturer's Screen

R-K Electronics  
DPM v0.0.00

### Average Voltage Screen

VAvg	Imb	Hz	
460	0	60	off

**Default – the default screen shows the real time voltage detected in each of the 3 phases:**

A-B	B-C	C-A	
460	459	461	ON

### Voltage Selection Screen (Vertical Format) Default = 460V, 3Ø

200, 1Ø; 208, 1Ø; 220, 1Ø; 230, 1Ø; 240, 1Ø;  
200, 3Ø; 208, 3Ø; 220, 3Ø; 230, 3Ø; 240, 3Ø; 380, 3Ø; 415, 3Ø; 440, 3Ø;  
460, 3Ø; 480 3Ø; 575, 3Ø; 600, 3Ø;

### Over/Under voltage Percentage Screen (Vertical Format) Default = 10%

7% 8% 9% 10% 11% 12% 13% 14% & 15%

### Trip Time Delay Screen (Vertical Format) Default = 5 sec

2S, 3S, 4S, 5S, 6S, 27S, 8S, 9S & 10S

### Re-Start Time Delay Screen (Vertical Format) Default = 2 sec

Manual, 2S, 3S, 4S, 5S, 6S, 7S, 8S, 9S, 10S, 30S, 1M, 2M, 3M & 4M

### Phase Imbalance Percentage Screen (Vertical Format) Default = 5%

3% 4% 5% 6% 7% 8% 9% & 10%

### Fault Screen (Vertical Format)

“0” most recent faults, “1” previous fault “2” third oldest fault & “3” fourth oldest fault.

### Fault Words:

“Phase a Loss”	(There is no voltage sensed on 3-L1/S)
“Voltage Low”	(Average line voltage is less than selected Undervoltage Percentage)
“Voltage High”	(Average line voltage is more than selected Overvoltage Percentage)
“Imbalance”	(One phase is lower than the average voltage by more than the Imbalance percentage)
“Phase Loss	(One phase is more than 30% below the Line Voltage selection)
“Bad Rotation”	(The phase rotation sequence is reversed)
“Bad Freq”	(Line frequency out of allowable range of 45 to 65 Hz)

### UV Lights

Some units include UV lights for airstream disinfection. The UV fixture is installed directly downstream of cooling coil. Door interlock switches are provided with this option. UV lamps ship loose in the vestibule and require installation during startup.

Useful lamp life shall be 9000 hours (minimum) with no more than a 15% output loss at the end of the lamps life.

 **WARNING**

**UV LIGHTS**  
  
 Never expose eyes or skin to UVC light from any source, as personal injury may result. Wear gloves, face shield/glasses (per ANSI Z87.1) and cover all exposed skin.

Table 43- Air Disinfection UV Information

RZ Cabinet Size	Cooling Coil Size	Model Option A3	CFM Max	Lamp Watt/SqFt Coil	Residence Time (Seconds)	Dose $\mu\text{J}/\text{cm}^2$ *	Estimated Inactivation Rate (Coronavirus)
A, B & C (45-140 tons)	Standard	A,B,E,F,G	27,300	15.47	0.474	1,037	98.00%
D (145-180 tons)			46,200	18.73	0.600	1,419	99.50%
E (200-240 tons)			60,800	14.23	0.794	1,320	99.30%
A, B & C (90-140 tons)	Large	C,D,H,J,K	37,500	38.67	0.394	1,348	99.40%
D (145-180 tons)			53,500	16.18	0.659	1,292	99.20%
E (200-240 tons)			72,900	13.84	0.900	1,377	99.40%

\* All dosage and estimated inactivation rates are at bulb end of life, have a wind chill degradation for 12.8°C (55°F) factored in, and factor in velocity on the coil. Warmer temperatures or lower airflows will increase the UV effectiveness.

### Filter Replacement

Monthly air filter inspection is required to maintain optimum unit efficiency.

Replace filter media monthly. Filters are located upstream of the evaporator coil in the filter and economizer section. Open access door and pull filters straight out to inspect all of the filters. Replace filters with the size indicated on each filter or as shown in Table 42.

 **WARNING**

Electric shock hazard. Shut off all electrical power to the unit to avoid shock hazard or injury from rotating parts.

Table 44 - RZ Series Filter Sizes

Unit Tonnage		MERV 8 Filters	4" Filters OR Cartridge Filters			32" Bag Filters		
			Box A	Box B	Box C	Box A	Box B	Box C
Air Cooled Condenser	Evaporative Condenser							
45	51	(24) 16x24 38,400 cfm	(4) 20x24 (12)24x24 36,800 cfm*	(20)24x24 48,000 cfm*	(6) 20x24 (18)24x24 55,200 cfm*	(4) 20x24 (12)24x24 38,300 cfm*	(16)24x24 40,000 cfm*	(20)24x24 50,000 cfm*
55	66							
65	73							
75	79	(36) 16x25 60,000 cfm	(4) 20x24 (12)24x24 36,800 cfm*	(20)24x24 48,000 cfm*	(6) 20x24 (18)24x24 55,200 cfm*	(4) 20x24 (12)24x24 38,300 cfm*	(16)24x24 40,000 cfm*	(20)24x24 50,000 cfm*
90	101							
105	109							
120	124	(36) 16x25 60,000 cfm	(4) 20x24 (12)24x24 36,800 cfm*	(20)24x24 48,000 cfm*	(6) 20x24 (18)24x24 55,200 cfm*	(4) 20x24 (12)24x24 38,300 cfm*	(16)24x24 40,000 cfm*	(20)24x24 50,000 cfm*
130	136							
140	148							
145	161	(60) 16x20 80,000 cfm	(5) 20x24 (15)24x24 46,000 cfm*	(25)24x24 60,000 cfm*	(8) 20x24 (24)24x24 73,600 cfm*	(5) 20x24 (15)24x24 47,900 cfm*	(20)24x24 50,000 cfm*	(25)24x24 62,500 cfm*
160	172							
180	197							
200	221	(72) 16x20 96,000 cfm	(5) 20x24 (15)24x24 46,000 cfm*	(25)24x24 60,000 cfm*	(8) 20x24 (24)24x24 73,600 cfm*	(5) 20x24 (15)24x24 47,900 cfm*	(20)24x24 50,000 cfm*	(25)24x24 62,500 cfm*
220	241							
240	261							

**\* Note: When used in Final position the unit CFM limit will be the lesser between these and the corresponding MERV 8 Pre-Filters.**

Filter Conversion Table	
Inches	Centimeters
[16 x 20 x 4]	[40.6 x 50.8 x 10.2]
[16 x 24 x 4]	[40.6 x 61 x 10.2]
[16 x 25 x 4]	[40.6 x 63.5 x 10.2]
[20 x 24 x 4]	[50.8 x 61 x 10.2]
[20 x 20 x 1]	[50.8 x 50.8 x 2.5]
[24 x 12 x 1]	[61 x 30.5 x 2.5]
[24 x 24 x 4]	[61 x 61 x 10.2]

Table 45 - Metal Mesh and HEPA Filter Sizes

Unit		Metal Mesh Filters		HEPA Filters	
		Standard Rain Hood	100% OA Ext Hood	Box A	Box B
Air Cooled Condenser	Evaporative Condenser				
45	51	(20) 20x20 33,300 cfm	(32)20x20 53,300 cfm	(9) 24x24 (6) 24x12 28,000 cfm*	(12) 24x24 (10) 24x12 40,800 cfm*
55	66				
65	73				
75	79				
90	101				
105	109				
120	124				
130	136				
140	148				
145	161	(28) 20x20 46,600 cfm	(48) 20x20 80,000 cfm	(15) 24x24 (5) 24x12 42,000 cfm*	(24) 24x24 (8) 24x12 67,200 cfm*
160	172				
180	197				
200	221				
220	241				
240	261				
* Note: When used in Final position the unit CFM limit will be the lesser between these and the corresponding MERV 8 Pre-Filters.					

**Replacement Parts**

Always use AAON specified parts. Parts for AAON equipment may be obtained from your local AAON representative. When ordering parts, reference the unit serial number and part number.

**Warranty:** Refer to the Limited Warranty Certificate for the unit warranty details. Contact your AAON representative for a unit specific copy of the certificate for your serial number.

**AAON Warranty, Service and Parts Department**

2424 S. Yukon Ave.  
Tulsa, OK 74107  
Ph: 918-382-6450  
techsupport@aaon.com  
www.AAON.com

**Note:** Before calling, technician must have model and serial number of the unit available for the customer service department to help answer questions regarding the unit.



## Limited Warranty Certificate

### GENERAL CONDITIONS

AAON, Inc. (hereinafter referred to as "AAON") warrants this AAON equipment, as identified hereon, to be free of defects in material and workmanship under normal use, service, and maintenance. Our obligations under this warranty must be limited to repairing or replacing the defective part, or parts, which in our judgment show evidence of such defects. AAON is not liable for labor charges and other costs incurred for removing, shipping, handling or transporting defective part, or parts, or for shipping, handling, transporting, or installing repaired or replacement part, or parts.

The limited warranty is effective one (1) year from date of **original installation**, or eighteen (18) months from date of original shipment from the factory, whichever occurs first and covers all parts and components in this AAON equipment excluding air filters, belts, refrigerant moisture driers, and lost refrigerant, which are not included in any part of this limited warranty. The replacement part, or parts, assume only the unused portion of the original limited warranty and are shipped f.o.b. from the factory and freight prepaid by the factory.

The limited warranty is effective for products manufactured at the Tulsa, Oklahoma or Longview, Texas facility.

**THIS LIMITED WARRANTY ONLY APPLIES WHEN THE ORIGINAL MODEL NUMBER AND SERIAL NUMBER OF THE AAON UNIT ARE GIVEN AT TIME OF REQUEST FOR REPLACEMENT PART, OR PARTS. DEFECTIVE PART, OR PARTS, MUST BE RETURNED PREPAID, WITH ITS ASSIGNED RETURN MATERIAL TAG, WITHIN FOURTEEN (14) DAYS OF RECEIPT OF THE REPLACEMENT PART, OR PARTS.**

### EXTENDED LIMITED WARRANTY ON COMPRESSORS INCLUDED IN SINGLE PACKAGE EQUIPMENT (NOT INCLUDING CHILLERS OR WH/WV); OPTIONAL ON OTHER EQUIPMENT

For the second through the fifth year from date of **shipment**, we further agree to repair or replace the fully hermetic compressor, at our option, for the **original purchaser-user only**. The repaired or replacement fully hermetic compressor will be supplied f.o.b. the factory, freight **prepaid and add**, providing the defective fully hermetic compressor is returned **prepaid by the customer**, and is proven to be inoperative due to defects in materials or workmanship. This extended limited warranty covers **only** the fully hermetic compressor and **does not include** any labor charges, or other additional costs incurred for removing, shipping, handling, transporting, or replacing the defective fully hermetic compressor. It also **does not include** additional costs incurred for shipping, handling, or transporting of electric controls such as relays, capacitors, pressure controls, or fan-motor assemblies, condensers, receivers, etc, which carry the standard **one-year limited warranty**.

### EXTENDED LIMITED WARRANTY OF WH/WV PRODUCTS

The WH/WV limited warranty is effective five (5) years from date of original installation. If installation date cannot be verified, limited warranty is effective five (5) years from date of equipment manufacture at the factory. Warranty covers all parts and components, including compressors, in this AAON equipment except those excluded in the general conditions.

### EXTENDED LIMITED WARRANTY OF RQ PRODUCTS

The RQ limited warranty is effective two (2) years from date of original **shipment** from the factory and covers all parts and components in this AAON equipment except those excluded in the general conditions.

### FOR OPTIONAL TWO YEAR EXTENDED LIMITED WARRANTY OF RN PRODUCTS

The limited warranty is effective two (2) years from date of original **shipment** from the factory and covers all parts and components in this AAON equipment except those excluded in the general conditions.

### FOR OPTIONAL FIVE YEAR EXTENDED LIMITED WARRANTY OF RN OR RQ PRODUCTS

The limited warranty is effective five (5) years from date of original **shipment** from the factory and covers all parts and components in this AAON equipment except those excluded in the general conditions.

### FOR OPTIONAL TEN YEAR EXTENDED LIMITED WARRANTY OF RN OR RQ PRODUCTS

The limited warranty is effective ten (10) years from date of original **shipment** from the factory and covers all parts and components in this AAON equipment except those excluded in the general conditions.

### FOR OPTIONAL FIVE YEAR EXTENDED LIMITED WARRANTY OF RN OR RQ ECONOMIZER WITH FAULT DETECTION AND DIAGNOSTICS

For the second through fifth year from date of shipment, we further warrant the economizer damper assembly against failure due to defects in materials and workmanship for the original purchaser-user only.

### EXTENDED LIMITED WARRANTY OF GAS FIRED HEAT EXCHANGERS

#### FOR RQ OR RN ALUMINIZED STEEL HEAT EXCHANGERS

For the second through the fifteenth year from date of **shipment**, we further warrant the steel heat exchanger against failure due to defects in materials and workmanship for the **original purchaser-user only**.

#### FOR RQ, RN, OR RZ STAINLESS STEEL HEAT EXCHANGERS

For the second through the twenty-fifth year from date of **shipment**, we further warrant the stainless steel heat exchanger against failure due to defects in materials and workmanship for the **original purchaser-user only**.

#### FOR RL SERIES HEAT EXCHANGERS

For the second through the tenth year from date of original installation, we further warrant the steel heat exchanger against failure due to defects in materials and workmanship for the original purchaser-user only, in accordance with the following: For the first five (5) years from date of shipment, we agree to repair or replace the heat exchanger, at our option, for the original purchaser-user only; during the sixth year, we will charge 50% of the current trade price for repaired or replacement steel heat exchanger, as the case may be, during the seventh year, 60%, during the eighth year, 70% during the ninth year, 80% and during the tenth year, 90%.

In all cases, the repaired or replacement heat exchanger will be supplied f.o.b. our factory, freight prepaid, providing the defective heat exchanger is returned **prepaid**, and if it is proved to be inoperative due to defects in materials and workmanship. This extended limited warranty covers **only** the heat exchanger and **does not include** labor charges, or other costs incurred for removing, shipping, handling, transporting, or installing repaired replacement heat exchanger. This extend limited warranty **does not apply** where the furnace has been operated in an atmosphere contaminated by chlorine, fluorine, or any other damaging chemical compounds.

### FOR OPTIONAL FIVE YEAR EXTENDED LIMITED WARRANTY OF COIL COATING

For the second through fifth year from date of shipment, we further warrant the coating of e-coated coils on the equipment against failure due to defects in materials and workmanship for the original purchaser-user only. Coil cleaning, maintenance, and record keeping must be followed according to the unit Installation, Operation and Maintenance Manual to maintain warranty.



# Limited Warranty Certificate

### OTHER CONDITIONS

This warranty **does not cover** any AAON unit or part thereof which has been subject to accident, negligence, damages in transit, misuse or abuse, **or which has been tampered with or altered in any way**, or which has **not been installed operated serviced and maintained** in accordance with our instructions, or which has been installed outside of the Continental United States or Canada, or on which the serial number or identification number has been altered defaced, or removed. AAON will not be responsible for failure of the unit to start due to voltage conditions, blown fuses, open circuit breakers, or other damages due to the inadequacy or interruption of electric service.

This warranty **does not cover** equipment containing a water-to-refrigerant heat exchanger for any damage resulting from freezing, fouling, corrosion or clogging.

AAON must not be liable for any default or delay in performance hereunder, caused by a contingency beyond its control, including governmental restrictions or restraint, strikes, short or reduced supply of raw materials or parts, floods, winds, fire, lightning strikes, or any other acts of God.

### DISCLAIMERS OF WARRANTIES

THIS WARRANTY IS EXCLUSIVE AND IS IN LIEU OF ANY WARRANTY OF MERCHANTABILITY, FITNESS FOR A PARTICULAR PURPOSE OR OTHER WARRANTY OF QUALITY, WHETHER EXPRESS OR IMPLIED, EXCEPT OF TITLE AND AGAINST PATENT INFRINGEMENT, CORRECTION OF NON-CONFORMITIES ARE LIMITED TO REPAIR OR REPLACEMENT OF THE DEFECTIVE PART OR PARTS, AT SELLER'S OPTION, WHICH MUST CONSTITUTE FULFILLMENT OF ALL TORT OR OTHERWISE IT IS EXPRESSLY UNDERSTOOD THAT AAON MUST NOT BE LIABLE FOR ANY CONSEQUENTIAL OR INCIDENTAL DAMAGES. AAON MUST NOT UNDER ANY CIRCUMSTANCES BE LIABLE FOR SPECIAL, INCIDENTAL OR CONSEQUENTIAL DAMAGES, SUCH AS, BUT NOT LIMITED TO DAMAGES OR LOSS OF OTHER PROPERTY OR EQUIPMENT, LOSS OF PROFITS OR REVENUE, COST OF CAPITAL, COST OF PURCHASED OR REPLACEMENT GOODS, OR CLAIMS OF BUYER OR USER FOR SERVICE INTERRUPTIONS. THE REMEDIES OF THE BUYER SET FORTH HEREIN ARE EXCLUSIVE, AND THE LIABILITY OF AAON WITH RESPECT TO ANY CONTRACT, OR ANYTHING DONE IN CONNECTION THEREWITH SUCH AS THE PERFORMANCE OR BREACH THEREFORE, OR FROM THE MANUFACTURE, SALE, DELIVERY, RESALE, INSTALLATION, OR USE OF ANY GOODS COVERED BY OR FURNISHED UNDER THIS CONTRACT WHETHER ARISING OUT OF CONTRACT, NEGLIGENCE, STRICT TORT, OR UNDER ANY WARRANTY, OR OTHERWISE, MUST NOT EXCEPT AS EXPRESSLY PROVIDED HEREIN, EXCEED THE PRICE OF THE GOODS UPON WHICH SUCH LIABILITY IS BASED.

WITH RESPECT TO THE GOODS SOLD, THE BUYER HEREBY WAIVES ALL LIABILITY ARISING FROM STATUTE, LAW, STRICT LIABILITY IN TORT, OR OTHERWISE, INCLUDING WITHOUT LIMITATION ANY OBLIGATION OF AAON WITH RESPECT TO CONSEQUENTIAL OR INCIDENTAL DAMAGES AND WHETHER OR NOT OCCASIONED BY AAON NEGLIGENCE. TIME LIMIT ON COMMENCING LEGAL ACTIONS: AN ACTION FOR BREACH OF THIS CONTRACT FOR GOOD SOLD OR ANY OTHER ACTION OTHERWISE ARISING OUT OF THIS CONTRACT, MUST BE COMMENCED WITHIN ONE (1) YEAR FROM THE DATE, THE RIGHT, CLAIM, DEMAND OR CAUSE OF ACTION MUST FIRST OCCUR, OR BE BARRED FOREVER.

### SEVERABILITY

IF ANY PROVISION OR CAUSE OF THIS CONTRACT OR APPLICATION THEREOF TO ANY PERSON OR CIRCUMSTANCES IS HELD INVALID OR UNCONSCIONABLE SUCH INVALIDITY OR UNCONSCIONABILITY MUST NOT AFFECT OTHER PROVISIONS OR APPLICATIONS OF THE CONTRACT WHICH CAN BE GIVEN EFFECT WITHOUT THE INVALID OR UNCONSCIONABLE PROVISIONS OF THE CONTRACT ARE DECLARED BE SEVERABLE.

### EQUIPMENT INFORMATION (REQUIRED)

**Job Name:** Click or tap here to

**Sales Order Number:** Click or tap here to enter text.

**Unit Tag:** Click or tap here to enter text

**Date of Shipment:** Click or tap here to enter text.

**Serial Number:** Click or tap here to enter text.

**Unit Model Number:** Click or tap here to enter text.



## Appendix A - Heat Exchanger Corrosion Resistance

### Corrosion Resistance of Copper and Stainless Steel in Brazed Plate Heat Exchangers - Points to Measure and Check in a Water Analysis

The resistance guide provides the corrosion resistance of stainless steel type AISI 316 and pure Copper (99.9%) in water, to a number of important chemical factors. The actual corrosion is a very complex process influenced by many different factors in combination.

Explanations: + Good resistance under normal conditions

0 Corrosion problems may occur especially when more factors are valued 0

- Use is not recommended

Water Containing	Concentration (mg/l or ppm)	Time Limits - Analyze Before	AISI 316	SMO 254	Copper Alloy	Nickel Alloy
Alkalinity (HCO <sub>3</sub> <sup>-</sup> )	< 70	Within 24 Hours	+	+	0	+
	70-300		+	+	+	+
	> 300		+	+	0/+	+
Sulfate (SO <sub>4</sub> <sup>2-</sup> )	< 70	No Limit	+	+	+	+
	70-300		+	+	0/-	+
	> 300		0	0	-	+
HCO <sub>3</sub> <sup>-</sup> / SO <sub>4</sub> <sup>2-</sup>	> 1.0	No Limit	+	+	+	+
	< 1.0		+	+	0/-	+
Electrical Conductivity	< 10µS/cm	No Limit	+	+	0	+
	10-500 µS/cm		+	+	+	+
	> 500 µS/cm		+	+	0	+
pH	< 6.0	Within 24 Hours	0	0	0	+
	6.0-7.5		0/+	+	0	+
	7.5-9.0		+	+	+	+
	> 9.0		+	+	0	+
Ammonium (NH <sub>4</sub> <sup>+</sup> )	< 2	Within 24 Hours	+	+	+	+
	2-20		+	+	0	+
	> 20		+	+	-	+
Chlorides (Cl <sup>-</sup> )*	< 300	No Limit	+	+	+	+
	> 300		0	+	0/+	+
Free Chlorine (Cl <sub>2</sub> )	< 1	Within 5 Hours	+	+	+	+
	1-5		+	+	0	+
	> 5		0/+	+	0/-	+
Hydrogen Sulfide (H <sub>2</sub> S)	< 0.05	No Limit	+	+	+	+
	> 0.05		+	+	0/-	+
Free (aggressive) Carbon Dioxide (CO <sub>2</sub> )	< 5	No Limit	+	+	+	+
	5-20		+	+	0	+
	> 20		+	+	-	+

\*See Chloride Content Table

Water Containing	Concentration (mg/l or ppm)	Time Limits - Analyze Before	AISI 316	SMO 254	Copper Alloy	Nickel Alloy
Total Hardness (°dH)	4.0-8.5	No Limit	+	+	+	+
Nitrate (NO <sub>3</sub> )	< 100	No Limit	+	+	+	+
	> 100		+	+	0	+
Iron (Fe)	< 0.2	No Limit	+	+	+	+
	> 0.2		+	+	0	+
Aluminum (Al)	< 0.2	No Limit	+	+	+	+
	> 0.2		+	+	0	+
Manganese (Mn)	< 0.1	No Limit	+	+	+	+
	> 0.1		+	+	0	+

#### Chloride Content

Chloride Content	Maximum Temperature			
	60°C (140°F)	80°C (176°F)	120°C (248°F)	130°C (266°F)
= 10 ppm	SS 304	SS 304	SS 304	SS 316
= 25 ppm	SS 304	SS 304	SS 316	SS 316
= 50 ppm	SS 304	SS 316	SS 316	Ti / SMO 254
= 80 ppm	SS 316	SS 316	SS 316	Ti / SMO 254
= 150 ppm	SS 316	SS 316	Ti / SMO 254	Ti / SMO 254
= 300 ppm	SS 316	Ti / SMO 254	Ti / SMO 254	Ti / SMO 254
> 300 ppm	Ti / SMO 254	Ti / SMO 254	Ti / SMO 254	Ti / SMO 254

## Appendix B - Thermistor Temperature vs. Resistance Values

Deg C	Deg F	Resistance (kOhms)
-40	-40	2889.6
-35	-31	2087.22
-30	-22	1522.20
-25	-13	1121.44
-20	-4	834.72
-15	5	627.28
-10	14	475.74
-5	23	363.99
0	32	280.82
5	41	218.41
10	50	171.17
15	59	135.14
20	68	107.44
25	77	86.00
30	86	69.28
35	95	56.16
40	104	45.81
45	113	37.58
50	122	30.99
55	131	25.68
60	140	21.40
65	149	17.91

Deg C	Deg F	Resistance (kOhms)
70	158	15.07
75	167	12.73
80	176	10.79
85	185	9.20
90	194	7.87
95	203	6.77
100	212	5.85
105	221	5.09
110	230	4.45
115	239	3.87
120	248	3.35
125	257	2.92
130	266	2.58
135	275	2.28
140	284	2.02
145	293	1.80
150	302	1.59
155	311	1.39
160	320	1.25
165	329	1.12
170	338	1.01
175	347	0.92
180	356	0.83

## RZ Series Startup Form

Date: _____	
Job Name: _____	
Job Address: _____	
Model Number: _____	
Serial Number: _____	Tag: _____
Startup Contractor: _____	
Contractor Address: _____	Phone: _____

<b>Pre Startup Checklist</b>		
Installing contractor must verify the following items.		
1. Is there any visible shipping damage?	Yes <input type="checkbox"/>	No <input type="checkbox"/>
2. Is the unit level?	Yes <input type="checkbox"/>	No <input type="checkbox"/>
3. Are the unit clearances adequate for service and operation?	Yes <input type="checkbox"/>	No <input type="checkbox"/>
4. Do all access doors open freely and are the handles operational?	Yes <input type="checkbox"/>	No <input type="checkbox"/>
5. Have all electrical connections been tested for tightness?	Yes <input type="checkbox"/>	No <input type="checkbox"/>
6. Does the electrical service correspond to the unit nameplate?	Yes <input type="checkbox"/>	No <input type="checkbox"/>
7. On 208/230V units, has transformer tap been checked?	Yes <input type="checkbox"/>	No <input type="checkbox"/>
8. Has overcurrent protection been installed to match the unit nameplate requirement?	Yes <input type="checkbox"/>	No <input type="checkbox"/>
9. Have all set screws on the fans been tightened?	Yes <input type="checkbox"/>	No <input type="checkbox"/>
10. Do all fans rotate freely?	Yes <input type="checkbox"/>	No <input type="checkbox"/>
11. Is all copper tubing isolated so that it does not rub?	Yes <input type="checkbox"/>	No <input type="checkbox"/>
12. Has outside air rain hood been opened?	Yes <input type="checkbox"/>	No <input type="checkbox"/>
13. Have the damper assemblies been inspected?	Yes <input type="checkbox"/>	No <input type="checkbox"/>
14. Are the air filters installed with proper orientation?	Yes <input type="checkbox"/>	No <input type="checkbox"/>
15. Have condensate drain and p-trap been connected?	Yes <input type="checkbox"/>	No <input type="checkbox"/>
16. 16. Has the outside air rain hood been opened?	Yes <input type="checkbox"/>	No <input type="checkbox"/>
17. Is the actual refrigerant charge of largest circuit in accordance with the required conditioned floor area according to Table 15?	Yes <input type="checkbox"/>	No <input type="checkbox"/>
18. Are ventilation and exhaust openings unobstructed?	Yes <input type="checkbox"/>	No <input type="checkbox"/>
19. Are markings, decals, and warnings on unit clearly visible?	Yes <input type="checkbox"/>	No <input type="checkbox"/>
20. Are all damaged or illegible markings and warnings replaced?	Yes <input type="checkbox"/>	No <input type="checkbox"/>

<b>Supply Fan Assembly</b>				
Alignment <input type="checkbox"/>		Check Rotation <input type="checkbox"/>		Nameplate Amps _____
Number	hp	L1 Volts/Amps	L2 Volts/Amps	L3 Volts/Amps
1				
2				
3				
4				
5				
6				
7				
8				
9				
10				
11				
12				
VFD Frequency _____		VAV Controls _____		

<b>Energy Recovery Wheel Assembly</b>				
Wheel(s) Spin Freely <input type="checkbox"/>		Check Rotation <input type="checkbox"/>		FLA _____
Number	hp	L1 Volts/Amps	L2 Volts/Amps	L3 Volts/Amps
1				
2				

<b>Power Return Assembly</b>				
Alignment <input type="checkbox"/>		Check Rotation <input type="checkbox"/>		Nameplate Amps _____
Number	hp	L1 Volts/Amps	L2 Volts/Amps	L3 Volts/Amps
1				
2				
VFD Frequency _____				

<b>Power Exhaust Assembly</b>				
Alignment <input type="checkbox"/>		Check Rotation <input type="checkbox"/>		Nameplate Amps _____
Number	hp	L1 Volts/Amps	L2 Volts/Amps	L3 Volts/Amps
1				
2				
VFD Frequency _____				

<b>Outside Air/Economizer Dampers</b>
Operation Check <input type="checkbox"/>
Damper Actuator Type:
Economizer Changeover Type and Operations:
Damper Wiring Check <input type="checkbox"/>
Gears Check <input type="checkbox"/>

<b>Unit Configuration</b>
Water-Cooled Condenser <input type="checkbox"/> Air-Cooled Condenser <input type="checkbox"/>
No Water Leaks <input type="checkbox"/> Evaporative Condenser <input type="checkbox"/>
Condenser Safety Check <input type="checkbox"/>
Water Flow _____ GPM
Water Inlet Temperature _____ °F
Water Outlet Temperature _____ °F

<b>Compressors / DX Cooling</b>						
Number/stage	L1 Volts/Amps	L2 Volts/Amps	L3 Volts/Amps	Head Pressure PSIG	Suction Pressure PSIG	Crankcase Heater Amps
1						
2						
3						
4						
5						
6						
7						
8						

Ambient DB Temperature _____ °C/°F	Ambient WB Temperature _____ °C/°F
Coil Entering Air DB Temperature _____ °C/°F	Coil Entering Air WB Temp _____ °C/°F
Coil Leaving Air DB Temperature _____ °C/°F	Coil Leaving Air WB Temp _____ °C/°F

<b>Refrigeration System 1</b>					
	Pressure	Saturated Temperature	Line Temperature	Sub-cooling	Superheat
Discharge				N/A	N/A
Suction				N/A	
Liquid					N/A
<b>Refrigeration System 2</b>					
	Pressure	Saturated Temperature	Line Temperature	Sub-cooling	Superheat
Discharge				N/A	N/A
Suction				N/A	
Liquid					N/A
<b>Refrigeration System 3</b>					
	Pressure	Saturated Temperature	Line Temperature	Sub-cooling	Superheat
Discharge				N/A	N/A
Suction				N/A	
Liquid					N/A
<b>Refrigeration System 4</b>					
	Pressure	Saturated Temperature	Line Temperature	Sub-cooling	Superheat
Discharge				N/A	N/A
Suction				N/A	
Liquid					N/A
<b>Refrigeration System 5</b>					
	Pressure	Saturated Temperature	Line Temperature	Sub-cooling	Superheat
Discharge				N/A	N/A
Suction				N/A	
Liquid					N/A
<b>Refrigeration System 6</b>					
	Pressure	Saturated Temperature	Line Temperature	Sub-cooling	Superheat
Discharge				N/A	N/A
Suction				N/A	
Liquid					N/A

<b>Condenser Fans</b>				
Alignment <input type="checkbox"/>		Check Rotation <input type="checkbox"/>		Nameplate Amps _____
Number	hp	L1 Volts/Amps	L2 Volts/Amps	L3 Volts/Amps
1				
2				
3				
4				
5				
6				
7				
8				
9				
10				
11				
12				
13				
14				
15				
16				
VFD Frequency _____				

<b>Evaporative Condenser Pumps</b>				
Check Rotation <input type="checkbox"/>				
Number	hp	L1 Volts/Amps	L2 Volts/Amps	L3 Volts/Amps
1				
2				

<b>Water/Glycol System</b>	
1. Has the entire system been flushed and pressure checked?	<input type="checkbox"/> Yes <input type="checkbox"/> No
2. Has the entire system been filled with fluid?	<input type="checkbox"/> Yes <input type="checkbox"/> No
3. Has air been bled from the heat exchangers and piping?	<input type="checkbox"/> Yes <input type="checkbox"/> No
4. Is the glycol the proper type and concentration (N/A if water)?	<input type="checkbox"/> Yes <input type="checkbox"/> No
5. Is there a minimum load of 50% of the design load?	<input type="checkbox"/> Yes <input type="checkbox"/> No
6. Has the water piping been insulated?	<input type="checkbox"/> Yes <input type="checkbox"/> No
7. What is the freeze point of the glycol (N/A if water)? _____	



<b>Gas Heating</b>		
Natural Gas <input type="checkbox"/> Propane <input type="checkbox"/> Purge Air from Lines <input type="checkbox"/> Verify Pilot Spark <input type="checkbox"/>		
Stage	Manifold Pressure (w.c.) inlet	Manifold Pressure (w.c.) outlet
1		
2		
3		
4		
5		
6		
7		
8		
9		
10		
11		
12		

<b>Electric Heating</b>		
Stages _____		
Limit Lockout <input type="checkbox"/> Aux. Limit Lockout <input type="checkbox"/>		
Stage	Volts/Amps	
1		
2		
3		
4		
5		
6		
7		
8		

**Maintenance Log**

This log must be kept with the unit. It is the responsibility of the owner and/or maintenance/service contractor to document any service, repair or adjustments. AAON Service and Warranty Departments are available to advise and provide phone help for proper operation and replacement parts. The responsibility for proper start-up, maintenance and servicing of the equipment falls to the owner and qualified licensed technician.

<b>Entry Date</b>	<b>Action Taken</b>	<b>Name/Tel.</b>

# Maintenance Log (E-Coated Coil)

## AAON E-COATED COIL MAINTENANCE RECORD

Installation Site \_\_\_\_\_ Installation Date \_\_\_\_\_  
 Unit Model # \_\_\_\_\_ Unit Location \_\_\_\_\_  
 Unit Serial # \_\_\_\_\_ Customer \_\_\_\_\_

Year 20__	Ambient Temp (°F)	Surface Debris Removed	Coil Cleaned	Approved Cleaner Used	Potable Water Backwash Rinse	Potable Water Frontwash Rinse	Chlorides Removed	Comments
Jan								
Feb								
Mar								
Apr								
May								
Jun								
Jul								
Aug								
Sep								
Oct								
Nov								
Dec								

The following cleaning agents have been approved for use on AAON E-Coated Coils to remove mold, mildew, dust, soot, greasy residue, lint and similar particulate without harming the coated surfaces.

CLEANING AGENT	RESELLER	PART NUMBER	RECOMMENDED CHLORIDE REMOVER
GulfClean™ Coil Cleaner or Enviro-Coil Cleaner	Rectorseal 2601 Spenwick Drive, Houston, Texas 77055 (P): 713-263-8001	G074480 / 80406 or V82540	Rectorseal 2601 Spenwick Drive, Houston, Texas 77055 (P): 713-263-8001
GulfClean Salt Reducer™	" "	G074490 / 80408	

# Literature Change History

## September 2020

Original version

## January 2022

Added Evaporative Condenser sections. Added several options to the Feature String Nomenclature for Features 1, 2, 3B, 5A, 5B, 5C, 6B, 6C, 9B, 9C, 15, 19, and 21. Updated RZ Variable Speed Compressor VFD Frequency Range table. Added Hot Water, Steam, and Chilled Water Coil Connection Sizes tables. Updated the Evaporator Coil removal and reinstallation instructions. Updated the Condenser Fan removal instructions. Updated the Electric and Gas Heating Capacities tables. Updated the RZ 45-140 ton Unit Gas Piping Connections table. Updated the RZ Series Filter Sizes table. Added installation instruction for HEPA and metal mesh filters.

## February 2022

Added direct fired gas heating sections. Removed the RZ Variable Speed Compressor VFD Frequency Range table.

## January 2023

Change compressor Hz warning from 25 Hz to 50 Hz. Added warning for heaters which recirculate room air, outside ventilation air must be provided in accordance with the information shown on the heater nameplate. Added recirculating operating limits and maximum temperature rise setpoints.

## November 2023

Start of new UL 60335 version of RZ series IOM. Added New UL 60335 tables and standard. Added 35 and 65 KAIC tables. Add Min and Max Water temps and pressures table. Added 454B Pressure Temperature charts as well as metric and imperial versions of 410A and 454B. Add new warning labels. Updated Feature string. Added metric conversions to all units in the IOM. Added option C to Feature 20. Added HEPA filter options to Feature 9. Adjusted CFM and filter quantities in Table 29.

## January 2024

Added statement about working with flammable refrigerants. Added Additional warnings. Added tables listing the max allowable charges for a circuit. Added warning about being cautious of expose live wire. Added caution to ensure wires are protected from damage and wear. Added to charging warning, "Maximum allowable charge of any single circuit is 133 kg (4700 oz)."









**AAON**  
**2425 South Yukon Ave.**  
**Tulsa, OK 74107-2728**  
**Phone: 918-583-2266**  
**Fax: 918-583-6094**  
**www.AAON.com**

**RZ Series**  
**Installation, Operation, &**  
**Maintenance**  
**G147570 · Rev. A · 240220**

It is the intent of AAON to provide accurate and current product information. However, in the interest of product improvement, AAON reserves the right to change pricing, specifications, and/or design of its product without notice, obligation, or liability.

Copyright © AAON, all rights reserved throughout the world.  
AAON® and AAONAIRE® are registered trademarks of AAON, Inc., Tulsa, OK.