



# SB Series

## Vertical Self-Contained Units



# Installation, Operation & Maintenance



**! WARNING**

**QUALIFIED INSTALLER**

Improper installation, adjustment, alteration, service or maintenance can cause property damage, personal injury or loss of life. Startup and service must be performed by a Factory Trained Service Technician . A copy of this IOM must be kept with the unit.

**! WARNING**

If the information in this manual is not followed exactly, a fire or explosion may result causing property damage, personal injury or loss of life.

**! WARNING**

**FOR YOUR SAFETY**

Do not store or use gasoline or other flammable vapors and liquids in the vicinity of this or any other appliance.



## Table of Contents

AAON SB Series Features and Options Introduction.....	6
Safety .....	7
SB Series Feature String Nomenclature .....	13
General Information.....	17
Codes and Ordinances .....	17
Receiving Unit .....	18
Storage .....	18
Direct Expansion (DX) Systems.....	18
Wiring Diagrams.....	19
Condensate Drain Pans .....	19
Installation.....	20
Locating the Unit .....	20
Lifting and Handling the Unit.....	21
Unit Assembly .....	21
Refrigerant-to-Water Heat Exchanger Water Piping.....	24
Electrical .....	28
Duct Connection .....	32
Condensate Drain Piping .....	32
Waterside Economizer .....	33
Heating Coils .....	34
Energy Recovery Units .....	34
Startup.....	43
Supply Fans.....	44
Fan Air Flow Adjustment .....	44
Filters .....	44
Adjusting Refrigerant Charge.....	45
Freeze Stat Startup .....	46
Operation.....	49
Packaged DX Cooling Operation and Control .....	49
Electric Heating Operation .....	49
Steam or Hot Water Preheating Operation .....	49
Maintenance.....	49
DX Cooling.....	49
Condensate Drain Pans .....	49
E-Coated Coil Cleaning.....	50
Supply Fans.....	51
Filter Replacement.....	52
Phase and Brownout Protection Module .....	52
Filter Information.....	55
Apendix A - Heat Exchanger Corrosion Resistance.....	60
<b>Maintenance Log (E-Coated Coil).....</b>	<b>66</b>

## Index of Tables and Figures

### Tables:

Table 1 - SB Series Clearances.....	20
Table 2 - Clearances for Coil Pull.....	20
Table 3 - Glycol Concentration Freezing Points (Metric) .....	26
Table 4 - Glycol Concentration Freezing Points (Imperial) .....	26
Table 5 - Condenser Water Connections .....	26
Table 6 - Water Connection Locations .....	27
Table 7 - Nameplate Voltage Markings & Tolerances .....	28
Table 8 - Control Wiring.....	31
Table 9 – 35 KAIC Fuse Sizing.....	32
Table 10 – 65 KAIC Fuse Sizing.....	32
Table 11 - Drain Trap Dimensions (Metric).....	33
Table 12 - Drain Trap Dimensions (Imperial) .....	33
Table 13 -Min and Max Water Pressure and Temps .....	34
Table 14 - Acceptable Water-Cooled Refrigeration Circuit Values (Metric).....	46
Table 15 - Acceptable Water-Cooled Refrigeration Circuit Values (Imperial).....	46
Table 16 - R-410A Refrigerant Temperature-Pressure Chart (Metric) .....	47
Table 17 - R-410A Refrigerant Temperature-Pressure Chart (Imperial).....	48
Table 18 - 3-5 ton (B Cabinet) Pre and Unit Filters .....	55
Table 19 - 6-10 ton (C Cabinet) Pre and Unit Filters .....	55
Table 20 - 14-18 ton (D Cabinet) Pre and Unit Filters .....	55
Table 21 - 3-5 ton (B Cabinet) Mixing Box Filters .....	56
Table 22 - 6-10 ton (C Cabinet) Mixing Box Filters .....	56
Table 23 - 14-18 ton (D Cabinet) Mixing Box Filters .....	57

Figures:

Figure 1 - Lockable Handle .....	18
Figure 2 - SB Series .....	20
Figure 3 - SB Series Unit Orientation.....	21
Figure 4 - SB Schematic with (1) Exhaust Fan, (2) Energy Recovery, (3) Air Handler, and (4) Compressor Section .....	22
Figure 5 - Connect Sections.....	22
Figure 6 - Bar Clamp .....	22
Figure 7 - Flange Overlap.....	22
Figure 8 - Self-Tapping Screw.....	22
Figure 9 - Strap Types.....	23
Figure 10 - Low Voltage Quick Connect.....	23
Figure 11 - Ship Split sections.....	24
Figure 12- Water Connections for Water-Source Heat Pumps.....	27
Figure 13 - Electrical Connection.....	29
Figure 14 - Drain Trap .....	32
Figure 15 - Energy Recovery Wheel .....	35
Figure 16 - Cross Section of Air Seal Structure .....	36
Figure 17 - Lifting Hole Locations .....	37
Figure 18 - Diameter Seal Adjustment .....	39
Figure 19 - Avoid Racking of Cassette Frame.....	40
Figure 20 - Diameter Seal Adjustment .....	41
Figure 21 - Hub Seal Adjustment .....	41
Figure 22 - Segment Retainer .....	41
Figure 23 - Segment Installation.....	42
Figure 24 - Belt Replacement .....	43
Figure 25 - Typical wiring diagram with EC motor .....	44
Figure 26 - Shows the jumper that is to be removed (jumped between S1 and S2). .....	44

G149170 · Rev. A · 240502  
(LV J000301)

## AAON SB Series Features and Options Introduction

### Energy Efficiency

- Direct Drive Backward Curved Plenum Supply Fans
- 10-100% Variable Capacity Scroll Compressors
- Double Wall Rigid Polyurethane Foam Injected Panel Construction
- Airside and Waterside Economizers
- Modulating SCR Electric Heat
- Modulating Head Pressure Control
- High Efficiency Electronically Commutated Motors
- Coaxial Refrigerant-to-Water Heat Exchanger
- Water-Source and Geothermal Heat Pumps
- Single Zone Variable Air Volume
- Energy Recovery Wheels

### Indoor Air Quality

- Up to 100% Outside Air with Optional Electric Pre-Heat
- Multiple High Efficiency Unit and Mixing Box Filters
- Double Wall Construction with No Exposed Insulation
- Stainless Steel Drain Pans

### Humidity Control

- 10-100% Variable Capacity Scroll Compressors
- Modulating Hot Gas Reheat

### Safety

- Freeze Stats
- Phase and Brown Out Protection

### Installation and Maintenance

- Direct Drive Backward Curved Plenum Supply Fans
- Clogged Filter Switch and Magnehelic Gauge
- Color Coded Wiring Diagram
- Isolated Compressor and Controls Compartment
- Compressor Isolation Valves
- Hinged Access Doors with Lockable Handles
- Liquid Line Sight Glass
- Split Configuration for Retrofit or Space Limited Applications

### System Integration

- Customer Provided Controls
- Electric, Steam, or Hot Water Heating
- Refrigerant-to-Water Heat Exchangers
- Condensing Unit Only Options
- Split System Configurations

### Environmentally Friendly

- R-410A Refrigerant
- Geothermal Heat Pump Configurations

### Extended Life

- Standard 5 Year Compressor Warranty
- Double Wall Rigid Polyurethane Foam Injected Cabinet Construction
- 2,500 Hour Salt Spray Tested Interior and Exterior Corrosion Protection
- Polymer E-Coated Coils - 5 Year Coating Warranty
- Stainless Steel Drain Pans
- Custom Color Paint Options

## Safety

Attention must be paid to the following statements:

**NOTE** - Notes are intended to clarify the unit installation, operation and maintenance.

**⚠ CAUTION** - Caution statements are given to prevent actions that may result in equipment damage, property damage, or personal injury.

**⚠ WARNING** - Warning statements are given to prevent actions that could result in equipment damage, property damage, personal injury or death.

### **⚠ WARNING**

#### **ELECTRIC SHOCK, FIRE OR EXPLOSION HAZARD**

Failure to follow safety warnings exactly could result in dangerous operation, serious injury, death or property damage.

Improper servicing could result in dangerous operation, serious injury, death or property damage.

- Before servicing, disconnect all electrical power to the unit. More than one disconnect may be provided.
- When servicing controls, label all wires prior to disconnecting. Reconnect wires correctly.
- Verify proper operation after servicing. Secure all doors with key-lock or nut and bolt.

### **⚠ WARNING**

Electric shock hazard. Before servicing, disconnect all electrical power to the unit, including remote disconnects, to avoid shock hazard or injury from rotating parts. Follow proper Lockout-Tagout procedures.

### **⚠ WARNING**

#### **FIRE, EXPLOSION OR CARBON MONOXIDE POISONING HAZARD**

Failure to replace proper controls could result in fire, explosion or carbon monoxide poisoning. Failure to follow safety warnings exactly could result in serious injury, death or property damage. Do not store or use gasoline or other flammable vapors and liquids in the vicinity of this appliance.

**! WARNING**

**CARBON MONOXIDE POISONING HAZARD**

Failure to follow instructions could result in severe personal injury or death due to carbon-monoxide poisoning, if combustion products infiltrate into the building.

Check that all openings in the outside wall around the vent (and air intake) pipe(s) are sealed to prevent infiltration of combustion products into the building.

Check that furnace vent (and air intake) terminal(s) are not obstructed in any way during all seasons.

**! WARNING**

During installation, testing, servicing and troubleshooting of the equipment it may be necessary to work with live electrical components. Only a qualified licensed electrician or individual properly trained in handling live electrical components shall perform these tasks.

Standard NFPA-70E, an OSHA regulation requiring an Arc Flash Boundary to be field established and marked for identification of where appropriate Personal Protective Equipment (PPE) be worn, must be followed.

**! WARNING**

**GROUNDING REQUIRED**

All field installed wiring must be completed by qualified personnel. Field installed wiring must comply with NEC/CEC, local and state electrical code requirements. Failure to follow code requirements could result in serious injury or death. Provide proper unit ground in accordance with these code requirements.

**! WARNING**

**UNIT HANDLING**

To prevent injury or death lifting equipment capacity shall exceed unit weight by an adequate safety factor. Always test-lift unit not more than 24 inches high to verify proper center of gravity lift point to avoid unit damage, injury or death.

**! WARNING**

**ROTATING COMPONENTS**

Unit contains fans with moving parts that can cause serious injury. Do not open door containing fans until the power to the unit has been disconnected and fan wheel has stopped rotating.



**! CAUTION**

Failure to properly drain and vent coils when not in use during freezing temperature may result in coil and equipment damage.

**! CAUTION**

Rotation must be checked on all MOTORS AND COMPRESSORS of 3 phase units at startup by a qualified service technician. Scroll compressors are directional and can be damaged if rotated in the wrong direction. Compressor rotation must be checked using suction and discharge gauges. Fan motor rotation must be checked for proper operation. Alterations must only be made at the unit power connection

**! WARNING**

**WATER PRESSURE**

Prior to connection of condensing water supply, verify water pressure is less than maximum pressure of 2068.4 kpa (300psi). To prevent injury or death due to instantaneous release of high pressure water, relief valves must be field supplied on system water piping.

**! WARNING**

Do not use oxygen, acetylene or air in place of refrigerant and dry nitrogen for leak testing. A violent explosion may result causing injury or death.

**! WARNING**

Always use a pressure regulator, valves and gauges to control incoming pressures when pressure testing a system. Excessive pressure may cause line ruptures, equipment damage or an explosion which may result in injury or death.

**! WARNING**

Do not work in a closed area where refrigerant or nitrogen gases may be leaking. A sufficient quantity of vapors may be present and cause injury or death.

**! CAUTION**

Do not clean DX refrigerant coils with hot water or steam. The use of hot water or steam on refrigerant coils will cause high pressure inside the coil tubing and damage to the coil.

**! CAUTION**

To prevent damage to the unit, do not use acidic chemical coil cleaners. Do not use alkaline chemical coil cleaners with a pH value greater than 8.5, after mixing, without first using an aluminum corrosion inhibitor in the cleaning solution.

**! WARNING**

Some chemical coil cleaning compounds are caustic or toxic. Use these substances only in accordance with the manufacturer's usage instructions. Failure to follow instructions may result in equipment damage, injury or death.

**! CAUTION**

Door compartments containing hazardous voltage or rotating parts are equipped with door latches to allow locks. Door latch are shipped with nut and bolts requiring tooled access. If you do not replace the shipping hardware with a pad lock always re-install the nut & bolt after closing the door.

**! CAUTION**

Unit power supply wire must be only copper or aluminum.

**! CAUTION**

Cleaning the cooling tower or the condenser water loop with harsh chemicals, such as hydrochloric acid (muriatic acid) or chlorine, can damage the water-cooled condenser. Care must be taken to avoid allowing chemicals to enter the water-cooled condenser. See Appendix A - Heat Exchanger Corrosion Resistance for more information.

**! WARNING**

**OPEN LOOP APPLICATIONS**

Failure of the condenser as a result of chemical corrosion is excluded from coverage under AAON Inc. warranties and the heat exchanger manufacturer's warranties.

**! WARNING**

**WATER FREEZING**

Failure of the condenser due to freezing will allow water to enter the refrigerant circuit and will cause extensive damage to the refrigerant circuit components. Any damage to the equipment as a result of water freezing in the condenser is excluded from coverage under AAON warranties and the heat exchanger manufacturer warranties.

**! CAUTION**

PVC (Polyvinyl Chloride) and CPVC (Chlorinated Polyvinyl Chloride) are vulnerable to attack by certain chemicals. Polyolester (POE) oils used with R-410A and other refrigerants, even in trace amounts, in a PVC or CPVC piping system will result in stress cracking of the piping and fittings and complete piping system failure.

**! WARNING**

This appliance is not intended for use by persons with reduced physical, sensory or mental capabilities, or lack of experience and knowledge, unless they have been given supervision or instruction concerning use of the appliance by a person responsible for their safety. Children must be supervised around this appliance.

**! WARNING**

Ensure that sufficient dampers will be open to provide air path before fan is allowed to run.

**! WARNING**

Do not weld or cut foam panel with plasma cutters or a cutting torch – When burnt the foam produces dangerous fumes.

**! WARNING**

**COMPRESSOR CYCLING**

**3 MINUTE MINIMUM OFF TIME**  
To prevent motor overheating compressors must cycle off for a minimum of 3 minutes.

**5 MINUTE MINIMUM ON TIME**  
To maintain the proper oil level compressors must cycle on for a minimum of 5 minutes.

The cycle rate must not exceed 7 starts per hour.

**! CAUTION**

In order to avoid a hazard due to inadvertent resetting of the THERMAL CUT-OUT, this appliance must not be supplied through an external switching device, such as a timer, or connected to a circuit that is regularly switched on and off by the utility.

**! WARNING**

Units with VFD driven motors/compressors have adjustable overload settings. These are set by the AAON factory for the protection of these motors/compressors and must not be adjusted over this factory setpoint or bypassed.

**! WARNING**

Only auxiliary devices approved by manufacturer or declared suitable with the refrigerant may be installed in ductwork.

**! WARNING**

Ensure that there are no live electrical components or wiring exposed when adjusting charge, recovering charge, or purging the system. Ensure that earthing continuity is unbroken.

**! WARNING**

Do not use torch or other potential ignition source to detect refrigerant leaks. Use only electronic detector suitable for the refrigerant, or bubble method with chlorine free detergent.

**! WARNING**

Do not use means to accelerate the defrosting process or to clean, other than those recommended in this manual.

1. Startup and service must be performed by a Factory Trained Service Technician.
2. The unit is for indoor use only. See General Information section for more unit information.
3. Every unit has a unique equipment nameplate with electrical, operational, and unit clearance specifications. Always refer to the unit nameplate for specific ratings unique to the model you have purchased.
4. READ THE ENTIRE INSTALLATION, OPERATION AND MAINTENANCE MANUAL. OTHER IMPORTANT SAFETY PRECAUTIONS ARE PROVIDED THROUGHOUT THIS MANUAL.
5. Keep this manual and all literature safeguarded near or on the unit.

# SB Series Feature String Nomenclature

Model Options										:	Unit Feature Options																											
GEN	SIZE	VLT	CONFIG	A1	A2	A3	A4	B1	B2	B3	1A	1B	1C	1D	2	3	4	5A	5B	5C	6A	6B	6C	7	8	9	10	11	12	13	14A	14B						
SB	007	3	0	E	7	0	9	0	0	0	:	0	0	0	0	-	0	0	0	-	A	B	C	-	0	A	0	-	0	0	0	0	0	0	Y	-	E	0

## MODEL OPTIONS

### Series and Generation

SB

### Unit Size

003 = 3 ton Capacity  
 004 = 4 ton Capacity  
 005 = 5 ton Capacity  
 006 = 6 ton Capacity  
 007 = 7 ton Capacity  
 009 = 9 ton Capacity  
 010 = 10 ton Capacity  
 014 = 14 ton Capacity  
 016 = 16 ton Capacity  
 018 = 18 ton Capacity

### Voltage

1 = 230V/1Φ/60Hz  
 2 = 230V/3Φ/60Hz  
 3 = 460V/3Φ/60Hz  
 4 = 575V/3Φ/60Hz  
 8 = 208V/3Φ/60Hz  
 9 = 208V/1Φ/60Hz

### Configuration

0 = Right Hand Unit + Top Vertical Discharge  
 A = Left Hand Unit + Top Vertical Discharge

### A1: Refrigerant Style

E = R-410A Variable Capacity Scroll Compressor (VCC)  
 L = R-454B Variable Capacity Scroll Compressor (VCC)

### A2: Unit Configuration

0 = Water-Cooled Condenser - Condensing Unit Only  
 7 = Water-Source/Geothermal Heat Pump + Std Evap. Coil - Coaxial Heat Exchanger  
 8 = Water-Source/Geothermal Heat Pump + 6 Row Evap. Coil - Coaxial Heat Exchanger  
 9 = Water-Source/Geothermal Heat Pump - Condensing Unit Only

### A3: Coil Coating

0 = Standard - None  
 1 = Polymer E-coated Cooling and Reheat Coils  
 5 = Copper Finned Coils + Stainless Steel Coil Casing

### A4: Cooling / Heat Pump Staging

A = Modulating - Variable Capacity Compressor

### B1: Heating Type

0 = No Heating  
 7 = Electric Heat  
 C = Steam Distributing Standard Coil  
 D = Steam Distributing Polymer E-Coated Coil  
 E = Hot Water Standard Coil  
 F = Hot Water Polymer E-Coated Coil

### B2: Heating Designation

0 = No Heating  
 1 = 1 Row Coil  
 2 = 2 Row Coil  
 A = 7 kW (5.3 kW @ 208V)  
 B = 14 kW (10.5 kW @ 208V)  
 C = 21 kW (15.8 kW @ 208V)  
 D = 28 kW (21.0 kW @ 208V)  
 E = 35 kW (26.3 kW @ 208V)  
 F = 42 kW (31.5 kW @ 208V)  
 G = 49 kW (37.0 kW @ 208V)  
 H = 56 kW (42.0 kW @ 208V)  
 J = 63 kW (47.3 kW @ 208V)  
 K = 70 kW (52.5 kW @ 208V)

### B3: Heating Staging

0 = No Heating  
 1 = 1 Stage  
 2 = 2 Stage  
 3 = 3 Stage  
 4 = 4 Stage  
 9 = Modulating/SCR Electric - Potentiometer Control  
 A = Modulating/SCR Electric - 0-10VDC Control Signal  
 H = Single Serpentine 8 fpi  
 J = Half Serpentine 8 fpi  
 K = Single Serpentine 10 fpi  
 L = Half Serpentine 10 fpi  
 M = Single Serpentine 12 fpi  
 N = Half Serpentine 12 fpi

# SB Series Feature String Nomenclature

Model Options																Unit Feature Options																					
GEN	SIZE	VLT	CONFIG	A1	A2	A3	A4	B1	B2	B3	1A	1B	1C	1D	2	3	4	5A	5B	5C	6A	6B	6C	7	8	9	10	11	12	13	14A	14B					
SB	-	007	-	3	-	0	-	E	7	0	A	-	0	0	0	0	0	:	0	0	0	0	0	0	0	0	0	0	0	0	0	0	0	Y	-	E	0
																			A	B	C	-	0	A	0	-	0	0	0	0	0	0	0	0	0	V	B

**UNIT FEATURE OPTIONS**

**1A: Return / Outside Air Section**

0 = Standard  
 2 = Mixing Box - Top and Front Openings

**1B: Exhaust Fan**

0 = Standard  
 A = 250 mm Exhaust Fan, 800 W EC Motor  
 B = 310 mm Exhaust Fan, 1.0 kW EC Motor  
 C = 310 mm Exhaust Fan, 1.7 kW EC Motor  
 D = 355 mm Exhaust Fan, 1.7 kW EC Motor  
 E = 450 mm Exhaust Fan, 3.0 kW EC Motor  
 F = 450 mm Exhaust Fan, 6.0 kW EC Motor  
 G = Dual 310 mm Exhaust Fan, 1.0 kW EC Motor  
 H = Dual 310 mm Exhaust Fan, 1.7 kW EC Motor  
 J = Dual 355 mm Exhaust Fan, 1.7 kW EC Motor  
 K = Dual 450 mm Exhaust Fan, 3.0 kW EC Motor  
 L = Dual 450 mm Exhaust Fan, 6.0 kW EC Motor  
 M = Option A + Piezo Ring  
 N = Option B + Piezo Ring  
 P = Option C + Piezo Ring  
 Q = Option D + Piezo Ring  
 R = Option E + Piezo Ring  
 S = Option F + Piezo Ring  
 T = Option G + Piezo Rings  
 U = Option H + Piezo Rings  
 V = Option J + Piezo Rings  
 W = Option K + Piezo Rings  
 Y = Option L + Piezo Rings

**1C: Filter Location**

0 = Standard

**1D: Mixing Box Damper Control**

0 = Standard - None  
 A = 2 Position Actuators (24V)  
 B = Fully Modulating Actuators (DDC)  
 C = Fixed Position Dampers  
 D = Fully Modulating Actuator - Enthalpy Limit  
 E = Fully Modulating Actuator - Sensible Limit

**2: Waterside Economizer**

0 = Standard - None

**3: Energy Recovery Type**

0 = Standard  
 A = Energy Recovery Wheel – Total + High CFM, Polymer  
 C = Energy Recovery Wheel – Total + High CFM, 1% Purge, Polymer  
 E = Energy Recovery Wheel – Sensible + High CFM, Polymer  
 G = Energy Recovery Wheel – Sensible + High CFM, 1% Purge, Polymer  
 J = Energy Recovery Wheel - Total + High CFM, Aluminum  
 L = Energy Recovery Wheel - Total + High CFM, 1% Purge, Aluminum

**4: Maintenance Options**

0 = Standard  
 A = Blower Aux. Contact - Low Voltage Terminal Block  
 B = Remote Start/Stop Terminals - Low Voltage Terminal Block  
 C = Options A + B

**5A: Supply Air Blower Configuration**

0 = No Airside - Condensing Unit Only  
 A = 1 Blower + High Efficiency EC Motor  
 B = 2 Blowers + High Efficiency EC Motors  
 C = Option A + Piezo Ring  
 D = Option B + Piezo Rings  
 E = 1 Blower + Perm Magnet AC TEFC Motor + VFD  
 F = 2 Blowers + 2 Perm Magnet AC TEFC Motors + 2 VFDs

# SB Series Feature String Nomenclature

Model Options

:

Unit Feature Options

GEN	SIZE	VLT	CONFIG	A1	A2	A3	A4	B1	B2	B3	1A	1B	1C	1D	2	3	4	5A	5B	5C	6A	6B	6C	7	8	9	10	11	12	13	14A	14B				
SB	- 007	- 3	- 0	- E	7	0	A	- 0	0	0	:	<b>0000</b>	<b>- 0000</b>	<b>- ABC</b>	- 0	A	0	- 0	0	0	0	0	0	0	0	0	0	0	0	Y	-	E	0			

**5B: Supply Air Blower**

- 0 = No Airside - Condensing Unit Only
- A = 310 mm (14") Direct Drive Backward Curved Plenum Fan
- B = 355 mm (16") Direct Drive Backward Curved Plenum Fan
- C = 450 mm (18") Direct Drive Backward Curved Plenum Fan
- D = 250 mm (12") Direct Drive Backward Curved Plenum Fan
- F = 13.5" Backward Curved Plenum Fan, 70% Width
- G = 15" Backward Curved Plenum Fan, 70% Width
- 1 = 15" Backward Curved Plenum Fan
- 4 = 18.5" Backward Curved Plenum Fan, 70% Width

**5C: Supply Air Blower Motor**

- 0 = No Airside - Condensing Unit Only
- B = 1.0 kW (1.34 hp)
- C = 1.7 kW (2.3 hp)
- D = 3.0 kW (4.0 hp)
- E = 6.0 kW (8.0 hp)
- F = 800 W (1.1 hp)
- 1 = 1 hp
- 2 = 2 hp
- 3 = 3 hp
- 4 = 5 hp

**6A: Pre-Filter Type**

- 0 = No Pre Filter
- A = 2" Pleated - MERV 8

**6B: Unit Filter Type**

- 0 = No Unit Filter
- A = 2" Pleated - MERV 8
- B = 4" Pleated - MERV 8
- C = 4" Pleated - MERV 11
- D = 4" Pleated - MERV 13
- E = 4" Pleated - MERV 14

**6C: Filter Options**

- 0 = Standard
- A = Clogged Filter Switch
- B = Magnehelic Gauge
- C = Options A + B

**7: Refrigeration Control**

- 0 = Standard
- C = Freeze Stat - Each Circuit

**8: Refrigeration Options**

- 0 = Standard
- D = Modulating Hot Gas Reheat

**9: Refrigeration Accessories**

- 0 = Standard
- A = Sight Glass
- B = Compressor Isolation Valves
- C = Options A + B

**10: Power Options**

- 0 = Standard Power Block

**11: Safety Options**

- 0 = Standard
- C = Supply Air Smoke Detector
- H = Remote Safety Shutoff Terminals
- L = Options C + H

**12: Controls**

- 0 = Standard
- A = Low Limit Controls
- B = Phase and Brown Out Protection
- C = Options A + B
- D = Energy Recovery Wheel Rotation Detection
- E = Options A+D
- F = Options B+D
- G = Options A+B+D

**13: Special Controls**

- D = VAV Unit Controller - VAV Cool + CV Heat
- Y = Single Zone VAV Heat Pump Unit Controller - VAV Cool + VAV Heat
- Z = Constant Volume Heat Pump Unit Controller - CV Cool + CV Heat
- 1 = Make Up Air Heat Pump Unit Controller - CV Cool + CV Heat
- 5 = Field Installed DDC Controls by Others with Isolation Relays
- 6 = Factory Installed DDC Controls Furnished by Others with Isolation Relays

# SB Series Feature String Nomenclature

Model Options

:

Unit Feature Options

GEN	SIZE	VLT	CONFIG	A1	A2	A3	A4	B1	B2	B3	1A	1B	1C	1D	2	3	4	5A	5B	5C	6A	6B	6C	7	8	9	10	11	12	13	14A	14B		
SB	-	007	-	3	-	0	-	E	7	0	A	-	0	0	0	0	:	0	0	0	0	0	0	0	0	0	0	0	0	0	0	0	0	0

**14A: Water-Cooled Condenser**

- B = Water Flow Switch
- E = Balancing Valves + Option B
- H = Motorized Shut-Off Valve + Option B
- J = Two Way Head Pressure Control + Option B
- L = Balancing Valves + Option H
- M = Balancing Valves + Option J
- T = CuNi Corrosion Resistant Coaxial Heat Exchanger + Option B
- W = CuNi Corrosion Resistant Coaxial Heat Exchanger + Option E
- 1 = CuNi Corrosion Resistant Coaxial Heat Exchanger + Option H
- 2 = CuNi Corrosion Resistant Coaxial Heat Exchanger + Option J
- 4 = CuNi Corrosion Resistant Coaxial Heat Exchanger + Option L
- 5 = CuNi Corrosion Resistant Coaxial Heat Exchanger + Option M

**14B: Waterside Economizer Piping**

- 0 = Standard - None

**15: Glycol Percentage**

- 0 = Standard - None
- A = Minimum 20% Propylene Glycol
- B = Minimum 40% Propylene Glycol

**16: Interior Cabinet Options**

- 0 = Standard - Double Wall Construction + R-6.5 Foam Insulation + Stainless Steel Drain Pan
- A = Overflow Switch
- B = Compressor Sound Blanket
- C = Options A + B

**17: Exterior Cabinet Options**

- 0 = No Paint
- A = AAON Gray Exterior Paint
- B = Special Paint
- C = Interior Corrosion Protection
- D = Options A + C

**18: Energy Recovery Cabinet**

- 0 = Standard - None
- A = Top RA + Back EA + Back OA Connections
- G = OA + EA Dampers - Top RA + Back EA + Back OA Connections
- N = OA + Economizer Dampers - Top RA + Back EA + Back Connections
- U = OA + EA + Economizer Dampers - Top RA + Back EA + Back OA Connections

**19: Code Options**

- 0 = Standard - ETL U.S.A. Listing
- H = ETL U.S.A. + Canada Listing

**20: Crating**

- 0 = Standard
- A = Export Crating
- B = Forkliftable Base - 5" Base
- D = Options A + B
- E = Shipping Shrink Wrap
- F = Options B + E
- G = Options A + B + E

**21: Unit Splits**

- 0 = Standard - One Piece Unit
- A = 1 Shipping Split (2 pallets)
- B = 2 Shipping Splits (3 pallets)
- C = 3 Shipping Splits (4 pallets)
- D = 4 Shipping Splits (5 pallets)
- H = Special Shipping Split (SPA Required)

**22: Control Vendors**

- 0 = Standard
- A = VCB-X Controls
- H = AAON Touchscreen Controller
- V = VCCX Controls

**23: Type**

- B = Standard
- X = Special Pricing Authorization



## General Information

SB Series self-contained units have been designed for indoor installation only. Units are assembled, wired, charged and run-tested at the factory.

### **WARNING**

Improper installation, adjustment, alteration, service or maintenance can cause property damage, personal injury or loss of life. Startup and service must be performed by a Factory Trained Service Technician. A copy of this IOM must be kept with the unit.

### **CAUTION**

These units must not be used as a "construction heater" at anytime during any phase of construction. Very low return air temperatures, harmful vapors, and misplacement of the filters will damage the unit and its efficiency.

### Certification of Steam or Hot Water Heat Models

- a. Certified as a forced air heating system with cooling.
- b. Certified for indoor installation only.

### Certification of Electric Heat Models

- a. Certified as an electric warm air furnace with cooling.
- b. Certified for indoor installation only.

### Certification of Cooling Models

- a. Certified as a commercial central air conditioner with electrically operated compressors.
- b. Certified for indoor installation only.
- c. Certified with refrigerant R-410A coils.

### Codes and Ordinances

SB Series units have been tested and certified, by ETL, in accordance with UL Safety Standard 1995 5<sup>th</sup> edition/CSA C22.2 No. 236 and Z21.47-2016.

Size system in accordance with the American Society of Heating, Refrigeration and Air Conditioning Engineers Handbook.

Installation of units must conform to the ICC standards of the International Mechanical Code, the International Building Code, Installation of Air Conditioning and Ventilating Systems Standard, NFPA 90A, and local building, plumbing and waste water codes. All appliances must be electrically grounded in accordance with local codes, or in the absence of local codes, the current National Electric Code, ANSI/NFPA 70 or the current Canadian Electrical Code CSA C22.1.

### **CAUTION**

The Clean Air Act of 1990 bans the intentional venting of refrigerant as of July 1, 1992. Approved methods of recovery, recycling, or reclaiming must be followed.

### **WARNING**

Coils and sheet metal surfaces present sharp edges and care must be taken when working with equipment.

**! WARNING**

Failure to observe the following instructions will result in premature failure of your system and possible voiding of the warranty.

**Receiving Unit**

When received, check the unit for damage that might have occurred in transit. If damage is found it must be noted on the carrier's Freight Bill. A request for inspection by carrier's agent must be made in writing at once.

Check nameplate to ensure the correct model sizes and voltages have been received to match the job requirements.

If repairs must be made to damaged goods, then the factory must be notified before any repair action is taken in order to protect the warranty. Certain equipment alteration, repair, and manipulation of equipment without the manufacturer's consent may void the product warranty. Contact the AAON Warranty Department for assistance with handling damaged goods, repairs, and freight claims: (918) 382-6450.

**Note:** Upon receipt check shipment for items that ship loose such as filters and remote sensors. Consult order and shipment documentation to identify potential loose-shipped items. Loose-shipped items may have been placed inside unit cabinet for security. Installers and owners must secure all doors with locks or nuts and bolts to prevent unauthorized access.



Figure 1 - Lockable Handle

**Storage**

If installation will not occur immediately following delivery, store equipment in a dry protected area away from construction traffic and in the proper orientation as marked on the packaging with all internal packaging in place. Secure all loose-shipped items. Unit must be stored in accordance with ASHRAE 15 requirements for machine rooms

**Direct Expansion (DX) Systems**

**! WARNING**

**COMPRESSOR CYCLING**

**3 MINUTE MINIMUM OFF TIME**

To prevent motor overheating compressors must cycle off for a minimum of 3 minutes.

**5 MINUTE MINIMUM ON TIME**

To maintain the proper oil level compressors must cycle on for a minimum of 5 minutes.

The cycle rate must not exceed 7 starts per hour.

All water-cooled condenser DX systems are factory assembled, leak tested, charged with R-410A refrigerant, and run tested.

All DX systems include evaporator coils, liquid line filter dryers, thermal expansion valves (TXV), and digital scroll compressors.

 <b>CAUTION</b>
<b>CRANKCASE HEATER</b>
Some units are equipped with compressor crankcase heaters, which must be energized at least 24 hours prior to condenser operation, to clear any liquid refrigerant from the compressors.

Never turn off the main power supply to the unit, except for servicing, emergency, or complete shutdown of the unit. When power is cut off from the unit crankcase heaters cannot prevent refrigerant migration into the compressors. This means the compressor may cool down and liquid refrigerant may accumulate in the compressor. The compressor is designed to pump refrigerant gas and damage may occur when power is restored.

If power to the unit must be off for more than an hour, turn the thermostat system switch to "OFF", or turn the unit off at the control panel, and leave the unit off until the main power switch has been turned on again for at least 24 hours for units with compressor crankcase heaters. This will give the crankcase heater time to clear any liquid accumulation out of the compressor before it is started.

Always control the unit from the thermostat, or control panel, never at the main power

supply, except for emergency or complete shutdown of the unit.

During the cooling season, if the air flow is reduced due to dirty air filters or any other reason, the cooling coils can get too cold which will cause excessive liquid to return to the compressor. As the liquid concentration builds up, oil is washed out of the compressor, leaving it starved for lubrication.

The compressor life will be seriously shorted by reduced lubrication and the pumping of excessive amounts of liquid oil and refrigerant.

### **Wiring Diagrams**

Unit specific wiring diagrams are laminated and affixed inside the controls compartment door.

### **Condensate Drain Pans**

Units require drain p-traps and lines to be connected to the condensate drain pans of the unit. The lines must be the same pipe size or larger than the drain connection, include a p-trap, and pitch downward toward drain. An air break must be used with long runs of condensate lines.

Waterside economizer coil units include a separate condensate drain pan which drains into the evaporator coil drain pan.

 <b>CAUTION</b>
Unit must not be operated without a p-trap. Failure to install a p-trap may result in overflow of condensate water.

## Installation

AAON equipment has been designed for quick and easy installation.

### Locating the Unit

Placement of the unit relative to ductwork, electrical and plumbing must be carefully considered. Return air plenum or duct can be mounted directly to the return air flanges. Use flexible gasket material to seal the duct to the unit.

Verify floor or foundation can support the total unit weight, including accessory weights. Unit must be level in both horizontal axes to support the unit and reduce noise and vibration from the unit. If unit is to be installed indoors, or in areas without sufficient ventilation, provide venting from all pressure relief outlets to outdoors in accordance with ASHRAE 15 requirements.

Allow adequate service clearances as shown on the unit nameplate and unit drawing. Consult your local building codes for additional service clearance requirements.

Allow adequate space for piping access and panel removal. Condenser water piping and condensate drain connections are located on either side of the unit.



Figure 2 - SB Series

Table 1 - SB Series Clearances

Location	Minimum Clearance Required
Access Door Sides	91.4 cm (36 inches) <sup>1</sup>
All Other Sides	15.2 cm (6 inches) <sup>2</sup>

1. Additional clearance may be required to allow for coil removal. See Table 2
2. May be installed flush depending upon local codes.

Table 2 - Clearances for Coil Pull

Unit Size	Access Side
SB 3-5 tons	81.3 cm (32 inches)
SB 6-10 tons	111.8 cm (44 inches)
SB 14-18 tons	147.3 cm (58 inches)

### CAUTION

Emergency drain pan is recommended for all applications where a risk of water damage to surrounding structure or furnishings. Refer to local codes.

### *Floor Mounted Units*

Make sure the unit is level and mounted on a field supplied platform with a minimum height to allow for proper depth of the condensate line p-trap. Other installation provisions may be necessary according to job specifications. SB Series vertical air handling units are designed for up flow applications only.

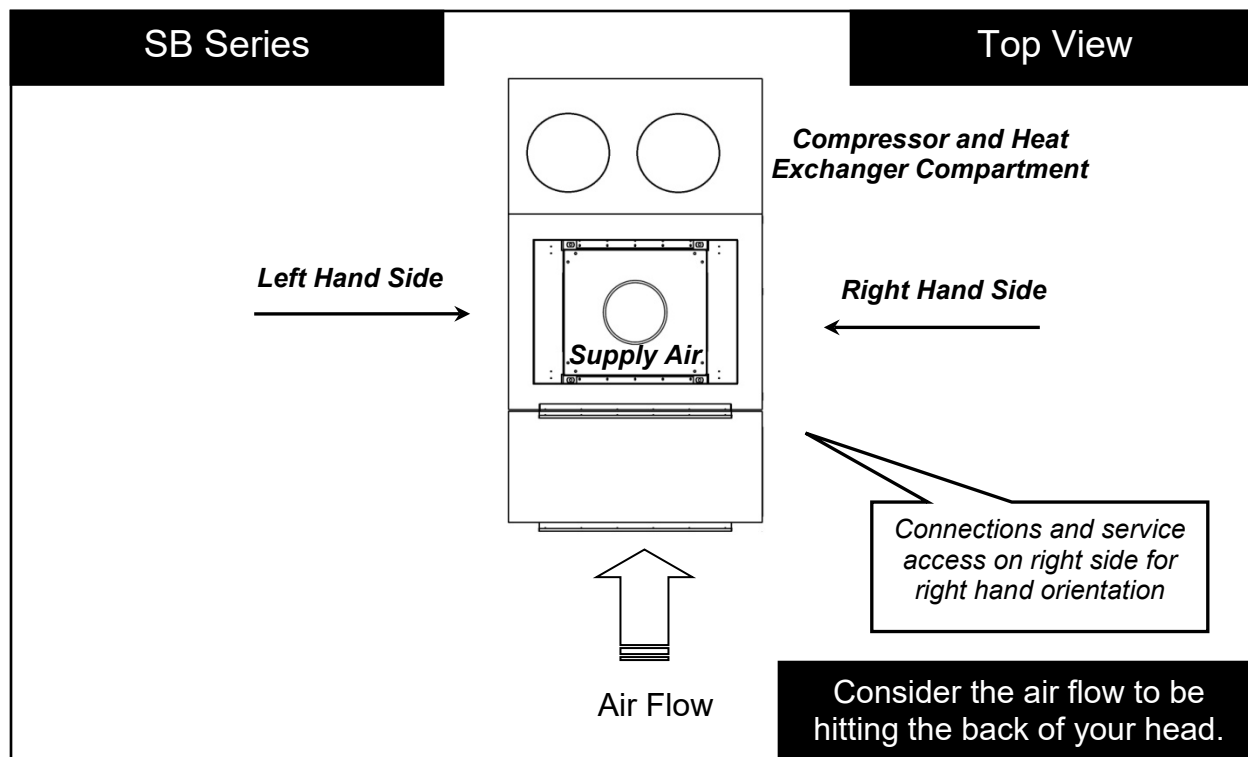

Figure 3 - SB Series Unit Orientation

### Lifting and Handling the Unit

Before lifting unit, be sure that all shipping material has been removed from unit.

**! WARNING**

**UNIT HANDLING**

Incorrect lifting can cause damage to the unit, injury or death. Lifting equipment capacity must exceed unit weight by an adequate safety factor. Always test lift unit not more than 61 cm (24 inches) high to verify proper center of gravity lift point.

Care must be taken if using spreader bars, blocking or other lifting devices to prevent damage to the cabinet, coil or fans.

### Unit Assembly

Although SB Series units are shipped factory assembled as standard, the unit may be ordered as shipping splits for certain applications such as for assembly in existing structures where modules must be manipulated separately. If the unit was ordered as shipping splits, then they must be assembled in the field.

If the Air Handler section and the Compressor section ship split, the refrigerant piping must be field installed to connect these two sections.

Locate the schematic in the equipment's literature packet.

1. *Identify and Situate Splits*

a. SB Units can have the following ship split sections:

1. Exhaust Fan
2. Energy Recovery
3. Air Handler
4. Water-Cooled Condenser
5. Electric Heat
6. Pre filter
7. Mixing box

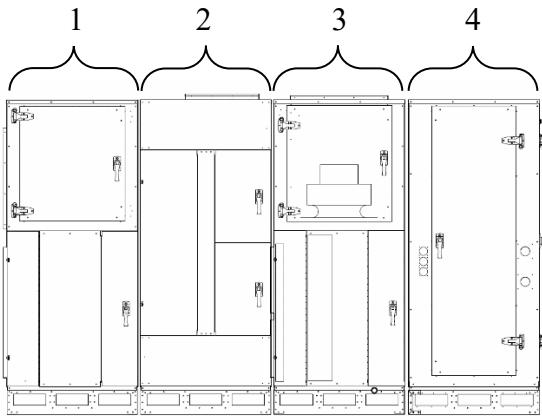

Figure 4 - SB Schematic with (1) Exhaust Fan, (2) Energy Recovery, (3) Air Handler, and (4) Compressor Section

2. *Connect Sections*

Using the SB Schematic as an example, section 1 will have a duct flange, and it will connect to section 2 on the side that does not have a flange. First make sure gasket is on the panel around the edges of the exposed duct flanges. Push section 1 and 2 together so that the flange from section 1 is inside of section 2.

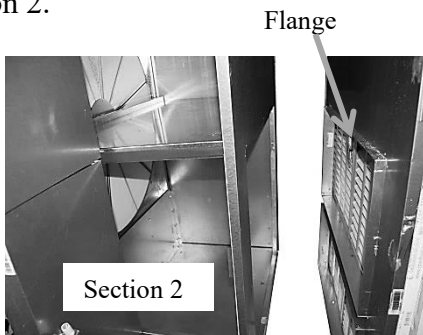

Figure 5 - Connect Sections

Use bar clamps or other non-destructive winching device to pull the tops of the modules together tightly.

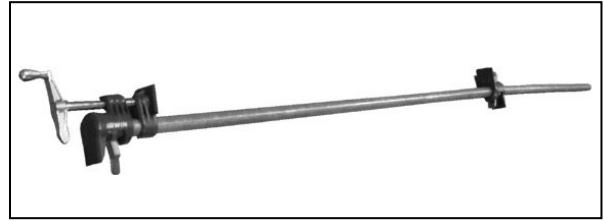

Figure 6 - Bar Clamp

At each of the pre-drilled holes in the flange, drill 8 mm (5/16") hex head self-tapping screws to secure the two sections together.

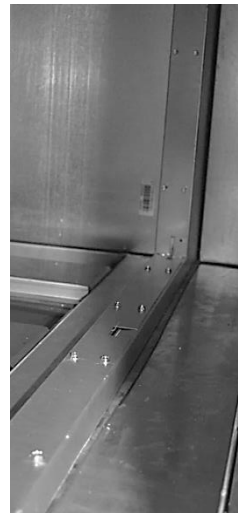

Figure 7 - Flange Overlap

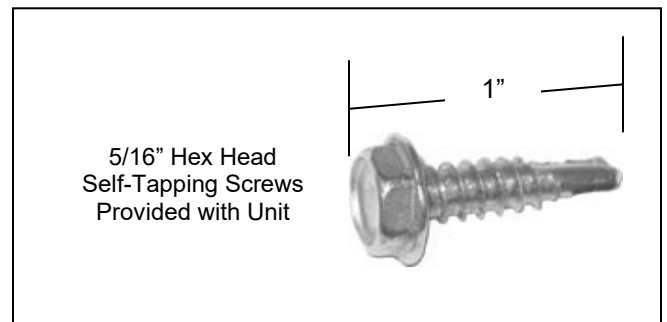

Figure 8 - Self-Tapping Screw

All connection hardware is shipped with the unit.

### 3. Secure Module Joints

The metal straps are to be used to secure module joints. Straps are provided with pre-drilled holes. Self-tapping sheet metal screws are provided to attach the straps to the unit cabinet.

Leave bar clamps in place until strap is secure.

Place the strap over a module joint, ensure the strap completely covers the joint, and that it is square with the unit casing.

Insert self-tapping screws through pre-drilled holes in strap and secure screws into unit casing using a power drill. For best results, use the lowest effective power drill torque setting. Be careful not to over tighten the screws.

Remove bar clamps and repeat for all remaining module joints.

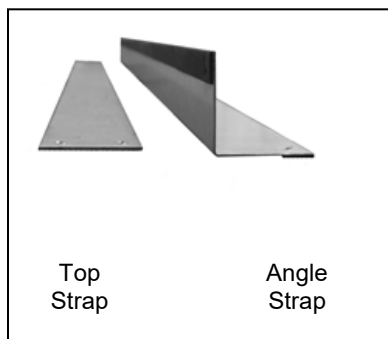

Figure 9 - Strap Types

### 4. Connect Power and Control Wiring

SB Series units are equipped with low and high voltage quick connects to connect wiring from one section to the next. Wire from the unit to external controls and power sources must be provided in the field.



Figure 10 - Low Voltage Quick Connect

A color-coded wiring diagram is laminated and affixed to the inside of the control compartment access door. SB Series units are equipped with a single point power connection.

### 5. Final Sealing

It is very important to keep air from infiltrating the unit cabinet. Seal all piping penetrations with Armaflex, Permagem or other suitable sealant. Also seal around drain connections, electrical connections and all other inlets where air may enter the cabinet. This is especially important when the unit is installed in an unconditioned area.

 <b>CAUTION</b>
Proper sealing of the electrical and piping entries into the unit must be verified by a qualified technician. Failure to seal the entries may result in damage to the unit and property.

## 6. Refrigerant Piping

If the Air Handler section and the Compressor section ship split, the refrigerant piping must be field installed to connect these two sections.



Figure 11 - Ship Split sections

### Refrigerant-to-Water Heat Exchanger Water Piping

Condenser water pump, condenser water piping, cooling tower, pressure gauges, strainers, piping insulation and all components of the waterside piping must be field installed.

#### *Open Loop Applications*

This product contains one or more refrigerant-to-water heat exchangers made of cupronickel or copper and is subject to severe corrosion and failure when exposed to chlorides.

## WARNING

### OPEN LOOP APPLICATIONS

Failure of the refrigerant-to-water heat exchanger as a result of chemical corrosion is excluded from coverage under AAON Inc. warranties and the heat exchanger manufacturer's warranties.

Do not allow water containing any form of chlorides to enter this heat exchanger.

Common forms of chlorides include:

1. Sea water mist entering an open cooling tower system.
2. Contaminated make-up water containing salt water.
3. Water loops disinfected with solutions containing sodium hypochlorite.

Chlorides will result in a premature failure of the refrigerant-to-water heat exchanger.

Failure of the refrigerant-to-water heat exchanger as a result of chemical corrosion is excluded from coverage under AAON warranties and the heat exchanger manufacturer warranties.

Failure of the refrigerant-to-water heat exchanger will allow water to enter the refrigerant circuit and will cause extensive damage to the refrigerant circuit components. Any damage to the equipment as a result of refrigerant-to-water heat exchanger failure from chemical corrosion due the fluid in the refrigerant-to-water heat exchanger is excluded from coverage under AAON warranties and the heat exchanger manufacturer warranties.



**! WARNING**

**OPEN LOOP APPLICATIONS**

Cupronickel refrigerant-to-water heat exchangers must be used with all open loop applications. Failure to use a Cupronickel heat exchanger may result in premature failure of your system and possible voiding of the warranty.

**! CAUTION**

Cleaning the cooling tower or condenser water loop with harsh chemicals such as hydrochloric acid (muriatic acid), chlorine or other chlorides, can damage the refrigerant-to-water heat exchanger. Care must be taken to avoid allowing chemicals to enter the refrigerant-to-water heat exchanger. See Appendix A - Heat Exchanger Corrosion Resistance for more information.

*Freezing Water in the Heat Exchanger*

This product contains one or more refrigerant-to-water heat exchangers. A refrigerant-to-water heat exchanger contains refrigerant in one passage and water in another passage. Water is subject to freezing at 0°C (32°F). When water freezes in a heat exchanger significant forces are exerted on the components of the heat exchanger where the water is confined.

Failure of the condenser due to freezing will allow water to enter the refrigerant circuit and will cause extensive damage to the refrigerant circuit components. Any damage

to the equipment as a result of water freezing in the condenser is excluded from coverage under AAON warranties and the heat exchanger manufacturer warranties.

**! WARNING**

**WATER FREEZING**

Failure of the condenser due to freezing will allow water to enter the refrigerant circuit and will cause extensive damage to the refrigerant circuit components. Any damage to the equipment as a result of water freezing in the condenser is excluded from coverage under AAON warranties and the heat exchanger manufacturer warranties.

Unit is capable of operating with Entering Water Temperatures (EWT) as low as 13.9°C (57°F) during cooling mode without the need for head pressure control. If the EWT is expected to be lower than 13.9°C (57°F) or more stable operation is desired, a factory provided head pressure control water valve option is available.

Glycol solutions are required if ambient temperatures are expected to fall below freezing or if the loop water temperature is below 10°C (50°F) while operating in the heating mode with the design minimum flow rate (heat pump units only). Adding glycol to condenser water causes an increase in pressure drop resulting in a decrease in unit performance. A minimum concentration of 20% glycol solution is required.

Table 3 - Glycol Concentration Freezing Points (Metric)

% Glycol	Ethylene Glycol	Propylene Glycol
20	-7.8°C	-7.2°C
30	-13.9°C	-12.8°C
40	-21.7°C	-21.1°C
50	-33.3°C	-32.8°C

Table 4 - Glycol Concentration Freezing Points (Imperial)

% Glycol	Ethylene Glycol	Propylene Glycol
20	18°F	19°F
30	7°F	9°F
40	-7°F	-6°F
50	-28°F	-27°F

Water loop piping runs through unheated areas or outside the building must be insulated.

Never operate the unit in heat pump mode with a saturated suction temperature below 1.7°C (35°F) for pure water systems or below the freezing point + (-16.1°C [3°F]) of the aqueous solution of water and glycol.

*Water Piping*

A water flow switch is factory installed between the condenser water supply and return connections. This sensor provides a signal to the unit controller that water flow is present in the heat exchanger and the unit can operate without damaging unit components.

**WARNING**

**WATER PRESSURE**

Prior to connection of condensing water supply, verify water pressure is less than maximum pressure of 2068.4 kpa (300 psi). To prevent injury or death due to instantaneous release of high pressure water, relief valves must be field supplied on water piping. Supply water connection may require a backflow preventer to prevent supply makeup water from backing up into the public water system.

**CAUTION**

PVC (Polyvinyl Chloride) and CPVC (Chlorinated Polyvinyl Chloride) are vulnerable to attack by certain chemicals. Polyolester (POE) oils used with R-410A and other refrigerants, even in trace amounts, in a PVC or CPVC piping system will result in stress cracking of the piping and fittings and complete piping system failure.

Only use approved water pipe material. Avoid using galvanized material for water lines/fittings as the material is corrosive and may cause fouling of the water system.

Table 5 - Condenser Water Connections

Model (SB-)	Supply and Return Connection Size (FPT)
003, 004, 005	25 mm (1")
006, 007	32 mm (1 1/4")
009, 010	38 mm (1 1/2")
014, 016, 018	51 mm (2")

Condenser water pump must be field sized and installed between the cooling tower or geothermal wellfield and self-contained unit. Size system in accordance with the ASHRAE Handbook. Use engineering guidelines to maintain equal distances for supply and return piping and limit bend radii to maintain balance in the system. Balancing valves, permanent thermometers and gauges may be required.

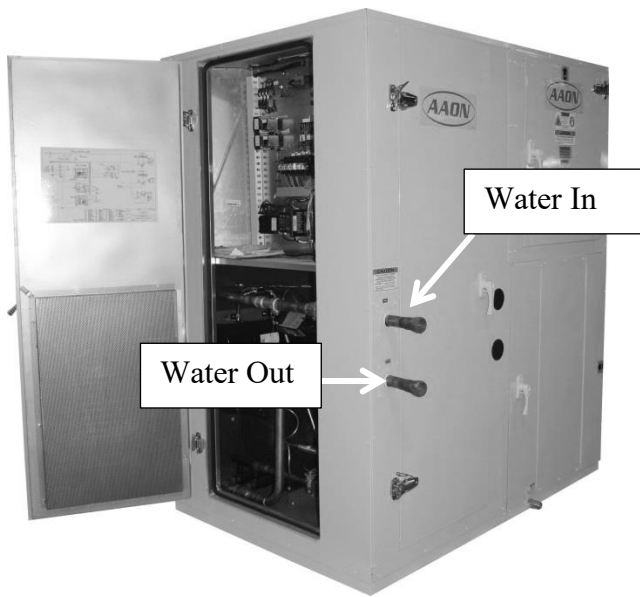

Figure 12- Water Connections for Water-Source Heat Pumps

Table 6 - Water Connection Locations

Unit Configuration	Locations
Water-Source Heat Pump	Water In - Top
	Water Out - Bottom
Water-Cooled Condenser	Water In - Bottom
	Water Out - Top

**! CAUTION**

Water system components must be properly sized and correctly installed by a qualified technician. Improper fluid flow due to valves, piping, or improper pump operation may result in unacceptable unit operation and void warranty.

**! CAUTION**

**WATER PIPING**

Follow national and local codes when installing water piping. Connections to the unit must incorporate vibration eliminators to reduce noise and vibration and shutoff valves to facilitate servicing. Supply and return water piping must be at least as large as the unit connections and larger depending on length of runs, rise and bends.

Before connection to the unit, flush the condenser water system to remove foreign material that could cause condenser fouling. Install a screen strainer with a minimum of 20 Mesh ahead of the condenser inlet to prevent condenser fouling and internal tube damage. Mineral content of the condenser water must be controlled. All make-up water has minerals in it and as the water is evaporated in the cooling tower, these minerals remain. As the mineral content of the water increases, the conductivity of the water increases.

Field provided and installed water treatment program must be compatible with stainless steel, copper, aluminum, ABS plastic, and PVC. Batch feed processes must never be used as concentrated chemicals can cause

corrosion. Never use hydrochloric acid (muriatic acid) or chlorine as it will corrode stainless steel.

Water loop piping runs through unheated areas or outside the building must be insulated.

**NOTE:** For unit isolation and water flow balancing, characterized ball valves must be factory or field installed in the condenser water supply and return. All manual flow valves in the condenser water system must be of the characterized ball valve design. Globe or gate valves must not be used due to high

pressure drops and poor throttling characteristics.

Pressure and temperature ports are recommended in condenser water supply and return lines for system balancing. These openings must be 5 to 10 pipe diameters from the unit water connections. To allow for mixing and temperature stabilization, wells in the water piping must extend at least 1/2 pipe diameter into the pipe.

Piping systems must not exceed 10 ft/sec fluid velocity to ensure tube wall integrity and reduce noise.

**Electrical**

For units not equipped with incoming power disconnect, means for all pole disconnection must be provided in the fixed wiring in accordance with local or national electrical codes The single point electrical power connections are made in the electrical control compartment.

Verify the unit nameplate agrees with the power supply. Connect power and control field wiring as shown on the unit wiring diagram provided with the unit.

Table 7 - Nameplate Voltage Markings & Tolerances

Hz	Nameplate Voltage	Nominal System Voltage	Operating Voltage Range <sup>1</sup>		Acceptable Performance Range <sup>2</sup>	
			Min	Max	Min	Max
60	115	120	104	127	108	126
	208/230	208/240	187	254	187	252
	208	208	187	228	187	228
	230	240	208	254	216	252
	265	277	240	293	249	291
	460	480	416	508	432	504
	575	600	520	635	540	630
50	230	230	198	254	208	254
	400	400	344	440	360	440

Notes:

1. Operating voltage is the min and max voltage for which the unit can function. Never operate outside of this min and max voltage.
2. The Acceptable Performance Range is the min and max voltage for which the unit performance is designed and rated to give acceptable performance.

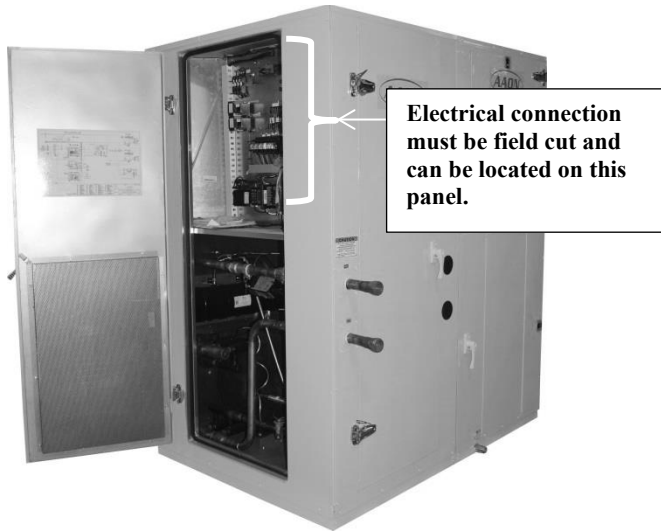



Figure 13 - Electrical Connection

 <b>WARNING</b>
<p>Disconnect all electrical power sources before servicing the unit. More than one power source may be provided. Failure to do so may result in injury or death from electrical shock or entanglement in moving parts.</p>

All units require field supplied electrical overcurrent and short circuit protection. Device must not be sized larger than the Maximum Overcurrent Protection (MOP) shown on the unit nameplate.

Codes may require a disconnect switch be within sight of the unit.

It is recommended that the field installed overcurrent protection or disconnect switch not be installed on the unit.

Electrical supply can enter through the bottom or side of the controls compartment. Entry must be field cut into panels of the unit.

A single point connection to a terminal block is provided. Split units may require

connection between the units. High voltage conductors must enter the control panel in a separate opening and separate conduit than 24V low voltage conductors.

 <b>WARNING</b>
<p>The foam insulation releases dangerous fumes when it is burnt. Do not cut a foam part with a cutting torch or plasma cutter. Do not weld to a foam filled part.</p>

**Note:** Locations for field cut electrical entries are marked on the unit. Field cut openings must be a minimum of 15.2 cm (6 inches) away from all components and wiring to prevent damage due to drilling or cutting.

To pass wires through the wall or roof of the unit, cut a hole and pass conduit through it. Use the following procedure to cut a round hole in a foam panel.

*Cutting Electrical Openings*

1. Locate the placement of the hole. Be sure that the conduit will not interfere with the operation of any component or prevent access of any door or removable panel.
2. Drill a pilot hole all the way through the foam panel.
3. Using a hole saw cut the hole through the metal on both sides of the foam part.
4. With a knife cut the foam out of the hole.
5. After the conduit is installed in the hole caulk the entire perimeter of the hole on both sides with an industrial grade silicone sealant or a duct seal compound.

 **CAUTION**

A qualified technician must ensure proper sealing of the electrical and gas entries into the unit. Failure to seal the entries may result in damage to the unit and property.

If a larger cut-out is needed for additional duct connections not provided by the factory, or for any other reason, it is very important that the foam be completely sealed. Insulation covers must be fabricated from sheet metal to cover the foam at the cut. The edges and corners that are not covered must then be sealed using silicone caulking or a duct seal compound.

If a reciprocating saw is used to make the cut-out take care that the metal skins of the foam part do not separate from the foam, this would result in reduced structural integrity of the part.

Size supply conductors based on the unit Minimum Current Ampacity (MCA) rating. Supply conductors must be rated a minimum of 75°C (167°F).

Protect the branch circuit in accordance with code requirements. The unit must be electrically grounded in accordance with local codes, or in the absence of local codes, the current National Electric Code, ANSI/NFPA 70 or the current Canadian Electrical Code CSA C22.1.

**Note:** Units are factory wired for 208V, 230V, 460V, or 575V. In some units, the 208V and 230V options may also be provided in single or three phase configurations. The transformer configuration must be checked by a qualified technician prior to startup.

Wire power leads to the unit's terminal block or main disconnect. All wiring beyond this point has been completed by AAON and cannot be modified without effecting the unit's agency/safety certification.

Supply voltage must be within the min/max range shown on the unit nameplate. Available short circuit current must not exceed the short circuit current rating (SCCR) shown on the unit nameplate.

 **CAUTION**

Three phase voltage imbalance will cause motor overheating and premature failure.

Three phase voltage imbalance will cause motor overheating and premature failure. The maximum allowable imbalance is 2%.

Voltage imbalance is defined as 100 times the maximum deviation from the average voltage divided by the average voltage.

Example:  
 $(221V+230V+227V)/3 = 226V$ , then  
 $100*(226V-221V)/226V = 2.2\%$ , which exceeds the allowable imbalance.

Check voltage imbalance at the unit disconnect switch and at the compressor terminal. Contact your local power company for line voltage corrections.

 **CAUTION**

Ensure that wires are protected from damage and wear caused by normal operation of unit and environmental factors.

A qualified technician must check for proper motor rotation and check blower motor

amperage listed on the motor nameplate is not exceeded.

**! CAUTION**

Rotation must be checked on all **MOTORS AND COMPRESSORS** of three phase units. Supply fan motors must all be checked by a qualified service technician at startup and any wiring alteration must only be made at the unit power connection.

Wire control signals to the unit’s low voltage terminal block located in the controls compartment.

**! CAUTION**

Scroll compressors are directional and will be damaged by operation in the wrong direction. Low pressure switches on compressors have been disconnected after factory testing. Rotation must be checked by a qualified service technician at startup using suction and discharge pressure gauges and any wiring alteration must only be made at the unit power connection.

*Thermostat Control Wiring*

If a thermostat is used for unit control, locate the thermostat on an inside wall 1.2-1.5 meters (4-5 feet) above the floor where it will not be subjected to drafts, sun exposure, or heat from electrical fixtures of appliances. Control wiring must deliver adequate voltage to components to assure proper operation. Control voltage returning from controller circuit must be a minimum of 21 VAC. To assure proper wiring use the following chart to determine the allowable wiring distances.

Table 8 - Control Wiring

Wire Size (Stranded) - Copper Conductors Only	Total Wire Distance Allowable	
20 AWG	60.96 m	200 ft
18 AWG	106.7 m	350 ft
16 AWG	152.4 m	500 ft
14 AWG	228.6 m	750 ft
12 AWG	381.0 m	1250 ft

Total Wire Distance Allowable =  
 (Quantity of Control Wires) x  
 (Control Wire Distance)

Take the total wire distance allowable and divide by the number of wires to be connected. This indicates the distance allowable for that size wire. The wiring to the unit must not exceed the total wire distance allowable. If the voltage at the connectors is less than 21 VAC, isolation relays must be installed. If under external control 21 VAC must be field verified.

All external devices must be powered via a separate external power supply.

Example:

A total of 8 wires must be pulled 75ft to a control the unit. What size wire must be used?

According to the Table 8, 16 AWG allows for 63ft (500 ft/8 wires) and 14 AWG allows for 94ft (750 ft/8 wires). Thus, 14 AWG must be used.

**Fuses and Circuit Breakers**

The interrupting rating of fuses and circuit breakers is to be determined based on the KAIC rating of the unit. Refer to the wiring diagram for fuse sizing.

Table 9 – 35 KAIC Fuse Sizing

35 KAIC Construction		
Component	Description	Interrupting Rating (kA)
Fuse	Class CC, 600V, 0.5A - 30A	200
Fuse	Class J, 600V, 35A - 600A	200
Disconnect	3P, 600V, 15A - 600A	35

Table 10 – 65 KAIC Fuse Sizing

65 KAIC Construction		
Component	Description	Interrupting Rating (kA)
Fuse	Class CC, 600V, 0.5A - 30A	200
Fuse	Class J, 600V, 35A - 600A	200
Disconnect	3P, 600V, 15A - 600A	65

### Duct Connection

Remove shipping covers and attach duct to flanges provided on the unit. The installer is responsible for sealing ducts to the flanges to prevent water leaks.

Intake air enters the back of the SB Series unit, where the air filters are located. Size ductwork in accordance with the ASHRAE Handbook. Ductwork must be installed in accordance with NFPA Standard 90A.

When attaching duct to the unit, use a flexible/compressible material rated for duct connections. A three inch flexible connector for both return and supply duct connections is recommended.

### Condensate Drain Piping

Unit is equipped with one condensate drain pan connection. A p-trap and drain line must be installed on at least one section's drain connection, with the p-trap not to exceed 15.2 cm (6") from the drain connection. The

lines must be the same pipe size or larger than the drain connection, include a p-trap, and pitch downward toward drain. An air break must be used with long runs of condensate lines.

**CAUTION**

Unit must not be operated without p-traps. Failure to install a p-trap may result in overflow of condensate water.

Draw-through cooling coils will have a negative static pressure in the drain pan area. This will cause an un-trapped drain to back up due to air being pulled up through the condensate drain piping.

Condensate drain trapping and piping must conform to all applicable governing codes.

**Note:** The drain pan connection(s) is a 2.5 cm (1") MPT fitting.

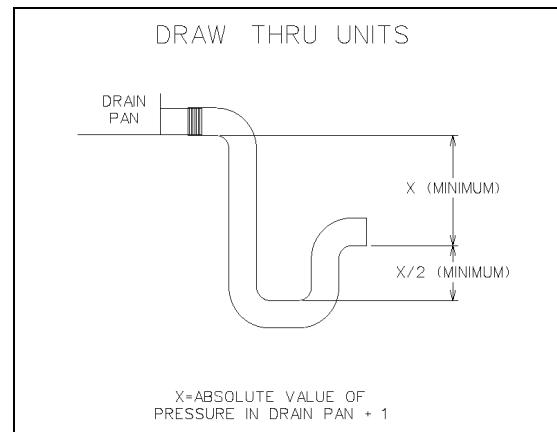

Figure 14 - Drain Trap

The X dimension on the draw-through trap must be at least equal to the absolute value of the negative static pressure in the drain pan plus one inch. To calculate the static pressure at the drain pan add the pressure drops of all components upstream of the drain pan, including the cooling coil, and add the return



duct static pressure. Include the dirt allowance pressure drop for the filters to account for the worst-case scenario.

The height from top of the bottom bend of the trap to the bottom of the leaving pipe must be at least equal to one half of the X dimension. This ensures that enough water is stored in the trap to prevent losing the drain seal during unit startup

**Note:** The absolute value of the fan inlet pressure will always be greater than or equal to the absolute value of the static pressure in the drain pan on draw-through units, so the fan inlet pressure is a safe value to use for the drain pan static pressure.

Table 11 - Drain Trap Dimensions (Metric)

Draw-Through		
Drain Pan Pressure	Trap Dimensions	
Negative Static (mm of mercury)	X (mm)	X/2 (mm)
-0.93	12.70	6.4
-1.87	25.40	12.7
-2.80	38.10	19.1
-3.74	50.80	25.4
-4.67	63.50	31.8
-5.60	76.20	38.1

Table 12 - Drain Trap Dimensions (Imperial)

Draw-Through		
Drain Pan Pressure	Trap Dimensions	
Negative Static (inches of water)	X (inch)	X/2 (inch)
-0.50	1.50	0.75
-1.00	2.00	1.00
-1.50	2.50	1.25
-2.00	3.00	1.50
-2.50	3.50	1.75
-3.00	4.00	2.00

### Waterside Economizer

Cooling and pre-cooling waterside economizer coil is factory installed upstream

of the evaporator coil. Factory tested and field installed water piping kit includes fully modulating waterside economizer valve and fully modulating waterside economizer bypass valve.

The waterside economizer circuit can operate in three modes: waterside economizer only, waterside economizer with mechanical cooling, and mechanical cooling only.

During waterside economizer only mode of operation condenser water flows through the waterside economizer coil with modulating valves maintaining supply air temperature setpoint. The condenser water completely bypasses the water-cooled condenser.

During waterside economizer with mechanical cooling mode of operation condenser water flows through the waterside economizer coil with the waterside economizer modulating valve fully open. The condenser water then passes through water-cooled condenser.

During mechanical cooling only mode of operation condenser water flows around the waterside economizer coil with the waterside economizer bypass valve fully open. The condenser water then passes through water-cooled condenser.

Waterside economizer coil condensate drain outlet drains into evaporator coil drain pan. See the previous section on evaporator coil condensate drain piping.

Mineral content of the condenser water must be controlled. All make-up water has minerals in it and as the water is evaporated in the cooling tower, these minerals remain. As the mineral content of the water increases, the conductivity of the water increases.

Field provided and installed water treatment program must be compatible with stainless steel, copper, aluminum, ABS plastic, and PVC. Batch feed processes must never be used as concentrated chemicals can cause corrosion. Never use hydrochloric acid (muriatic acid) or chlorine as it will corrode stainless steel.

**Heating Coils**

Factory installed one or two row hot water and steam heating coils can be factory mounted. These coils are supplied from a source through separate piping from the condenser water source. All controls for heating operation are field supplied and field installed.

Always connect the supply to the top of the coil and the return to the bottom. Water coils must not be subjected to entering air temperatures below 3.3°C (38°F) to prevent coil freeze-up. If air temperature across the coil is going to be below this value, use a glycol solution to match the coldest air expected.

 **WARNING**

Piping shall be in accordance with national and local codes. Pressure limiting devices, backflow preventers and all other safety requirements must be verified by a qualified technician.

 **CAUTION**

Proper sealing of the water piping entries into the unit must be verified by a qualified technician. Failure to seal the entries may result in damage to the unit and property.

**Energy Recovery Units**

Some SB units have been equipped with an energy recovery wheel. This section is provided to assure the energy recovery feature will be properly setup to perform in accordance with the job specifications for your particular application.

Table 13 -Min and Max Water Pressure and Temps

	Hot Water
Min. Entering Air	4.4 °C (40°F)
Max Entering Air	26.7°C (80°F)
Min. Entering Water	60°C (140°F)
Max Entering Water	93.3°C (200°F)
Min. Water Pressure	0 kpa (15 psig)
Max Water Pressure	2068kpa (300 psig)

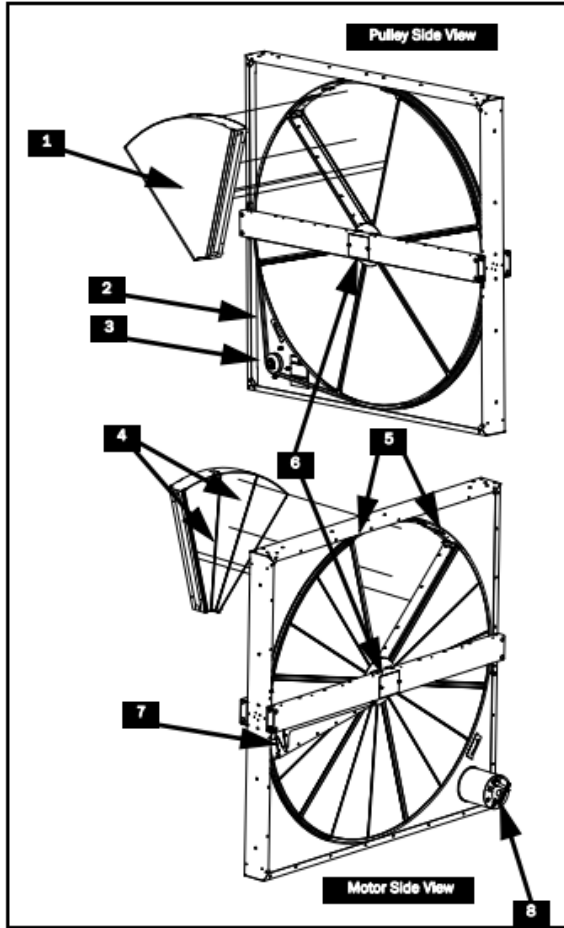

Figure 15 - Energy Recovery Wheel

1. Removable Segment (NA for monolith)
2. Permanent Tension Belt
3. Pulley
4. Embedded Segment Stiffeners (NA for monolith)
5. Segment Retaining Latches (NA for monolith)
6. Bearing Beam and Bearing Access Cover Plate (Diameter Seals are behind Bearing Beam on both sides)
7. Adjustable Purge
8. Motor

The Energy Recovery Cassette consists of a frame wheel, wheel drive system, and energy transfer segments. Segments are removable for cleaning or replacement. The segments rotate through counter flowing exhaust and

outdoor air supply streams where they transfer heat and/or water vapor from the warm, moist air stream to the cooler and/or drier air stream.

The initial setup and servicing of the energy recovery wheel is very important to maintain proper operation efficiency and building occupant comfort.

Normal maintenance requires periodic inspection of filters, the cassette wheel, drive belts, air seals, wheel drive motor, and its electrical connections.

Wiring diagrams are provided with each motor. When wired according to wiring diagram, motor rotates clockwise when viewed from the shaft/pulley side.

By carefully reviewing the information within this section and following the instructions, the risk of improper operation and/or component damage will be minimized.

It is important that periodic maintenance be performed to help assure trouble free operation.

### Initial Mechanical Check and Setup

Outdoor air intake adjustments must be made according to building ventilation, or local code requirements.

After the unit installation is complete, open the cassette access door and determine that the energy wheel rotates freely when turned by hand with no interference noise. Apply power and observe that the wheel rotates at approximately 45-50 RPM. If the wheel does not rotate when power is applied, it may be necessary to readjust the “diameter air seals”.

### Air Seal Adjustments

Pile type air seals across both sides of the energy wheel diameter are factory adjusted to provide close clearance between the air seal and wheel.

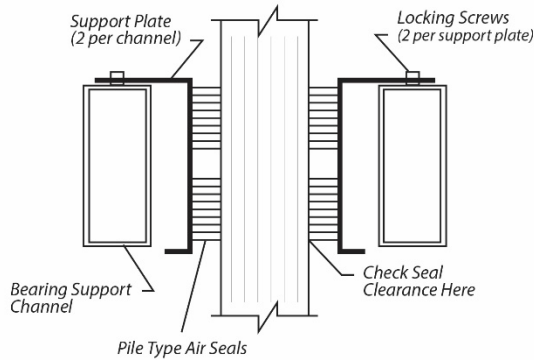

Figure 16 - Cross Section of Air Seal Structure

Racking of the unit or cassette during installation, and/or mounting of the unit on a non-level support or in other than the factory orientation can change seal clearances. Tight seals will prevent rotation.

### Wheel to Air Seal Clearance

To check wheel to seal clearance; first disconnect power to the unit, in some units the energy recovery wheel assembly can be pulled out from the cabinet to view the air seals. On larger units, the energy recovery wheel may be accessible inside the walk-in cabinet.

A business card or two pieces of paper can be used as a feeler gauge, (typically each 0.1 mm (.004”) thick) by placing it between the face of the wheel and pile seal.

Using the paper, determine if a loose slip fit exist between the pile seal and wheel when the wheel is rotated by hand.

To adjust air seal clearance, loosen all seal plate retaining screws holding the separate seal retaining plates to the bearing support

channels and slide the seals plates away from the wheel. Using the paper feeler gauge, readjust and retighten one seal plate at a time to provide slip fit clearance when the wheel is rotated by hand.

Confirm that the wheel rotates freely. Apply power to the unit and confirm rotation. Visually inspect the belt and ensure the belt is tracking near the center of the rim. Verify the wheel speed is approximately 45-50 RPM. Confirm there is no excessive noise such as scraping, brushing, or banging.

### Set Purge Angle (if included)

When installed, the purge angle is factory set to 5 degrees. If a different angle is required, complete the following steps to adjust the purge:

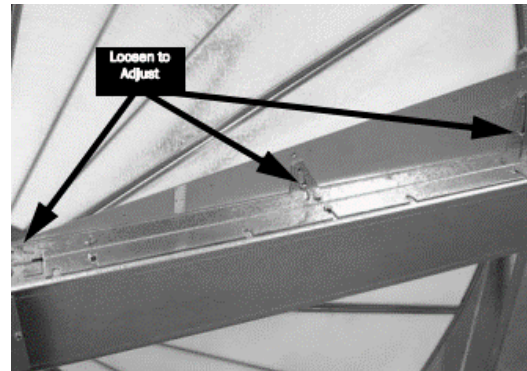

1. Loosen the three purge adjusting screws.
2. Adjust purge sector to the specified angle.

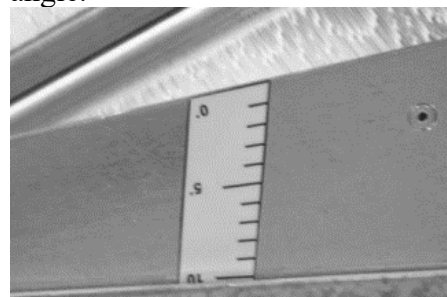

3. Tighten the purge adjusting screws.

- Turn the wheel by hand clockwise (when viewed from pulley side) to check for interference.

### Check Purge Seal

If a purge is installed, check for a slight interference fit between the seal and the face of the wheel by sliding a piece of paper (“feeler gauge”) between the seal and the media a multiple locations along the purge seal as you rotate the wheel slowly by hand (clockwise when viewed from the pulley side). Verify that the media slightly grabs the paper during rotation.

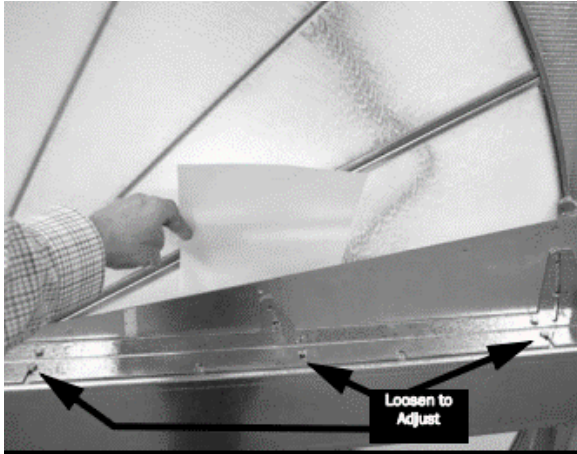

If it is necessary to adjust a purge seal to the face of the wheel, loosen the two or three screws along the bearing beam and adjust to the proper distance from the media surface. Tighten the screws and retest the seal.

### Airflow Balancing and Checking

High performance systems commonly have complex air distribution and fan systems. Unqualified personnel must not attempt to adjust fan operation, or air circulation, as all systems have unique operations characteristics. Professional air balance specialists must be employed to establish actual operating conditions, and to configure the air delivery system for optimal performance.

### Controls

A variety of controls and electrical accessories may be provided with the equipment. Identify the controls on each unit by consulting appropriate submittal, or order documents, and operate according to the control manufacturer’s instructions. If you cannot locate installation, operation, or maintenance information for the specific controls, then contact your sales representative, or the control manufacturer for assistance.

**⚠ WARNING**

Do not alter factory wiring. Deviation from the supplied wiring diagram will void all warranties, and may result in equipment damage or personal injury. Contact the factory with wiring discrepancies.

### Routine Maintenance and Handling

Handle cassettes with care. All cassettes must be lifted by the bearing support beam. Holes are provided on both sides of the bearing support beams to facilitate rigging as shown in the following illustration.

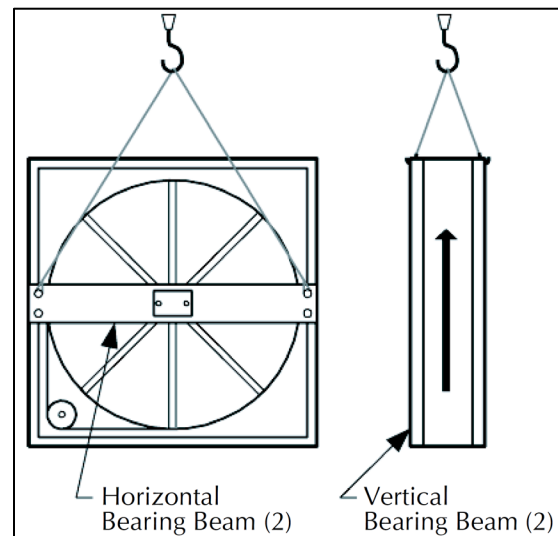

Figure 17 - Lifting Hole Locations

Routine maintenance of the Energy Recovery Cassettes includes periodic cleaning of the Energy Recovery Wheel as well as inspection of the Air Seals and Wheel Drive Components as follows:

**Cleaning**

Cleaning the energy transfer media will help maintain optimal performance. The frequency of cleaning is largely dependent on the application and air quality. Use ASHRAE’s Classes of Air categories, to create a routine cleaning schedule.

Class 1 air has low contaminant concentration with inoffensive odor and sensory irritation intensity.

Class 2 air has moderate contaminant concentration, with mildly offensive odors or sensory-irritation intensity.

Class 3 air has significant contaminant concentration and significant offensive odor or sensory-irritation intensity.

Class 4 air has highly objectionable fumes or gases and potentially contains dangerous particles, bio-aerosols, or gases at a concentration high enough to be considered harmful, not suitable for recirculation or transfer to any other space.

Class of Air	Examples	Cleaning Frequency
Class 1 Clean Air	<ul style="list-style-type: none"> <li>• Offices</li> <li>• Classrooms</li> <li>• Assembly rooms</li> <li>• Churches</li> </ul>	Every 8-10 years
Class 2 Moderately Clean Air	<ul style="list-style-type: none"> <li>• Restrooms</li> <li>• Swimming pools</li> <li>• Dining rooms</li> <li>• Locker rooms</li> <li>• Warehouse</li> <li>• Dorms</li> </ul>	Every 4-6 years
Class 3 Dirty Air	<ul style="list-style-type: none"> <li>• Kitchens</li> <li>• Dry cleaners</li> <li>• Beauty salons</li> <li>• Laboratories</li> <li>• Pet shops</li> </ul>	Every 1-2 years
Class 4 Contaminated Air	<ul style="list-style-type: none"> <li>• Paint spray booths</li> <li>• Laboratory fume exhaust</li> <li>• Kitchen grease exhaust</li> </ul>	Do not use in this application

The energy recovery wheel is “self-cleaning” with respect to dry particles due to its laminar flow characteristics. Smaller particles pass through; larger particles land on the surface and are blown clear as the flow direction is reversed. Any material that builds up on the face of the wheel can be removed with a brush or vacuum. The primary need for

cleaning is to remove oil based aerosols that have condensed on energy transfer surfaces.

A characteristic of all dry desiccants, such films can close off micron sized pores at the surface of the desiccant material, reducing the efficiency by which the desiccant can

adsorb and desorb moisture and also build up so as to reduce airflow.

In a reasonably clean indoor environment such as a school or office building, measurable reductions of airflow or loss of sensible (temperature) effectiveness may not occur for several years. Measurable changes in latent energy (water vapor) transfer can occur in shorter periods of time in applications such as moderate occupant smoking or cooking facilities. In applications experiencing unusually high levels of occupant smoking or oil based aerosols such as industrial applications involving the ventilation of machine shop areas for example, annual washing of energy transfer may be necessary to maintain latent transfer efficiency. Proper cleaning of the energy recovery wheel will restore latent effectiveness to near original performance.

To clean, gain access to the energy recovery wheel and remove segments. Brush foreign material from the face of the wheel. Wash the segments or small wheels in a 5% solution of non-acid based coil cleaner or alkaline detergent and warm water.

 <b>CAUTION</b>
<b>Do Not use acid based cleaners, aromatic solvents, steam or temperatures in excess of 76.7°C (170°F); damage to the wheel may occur!</b>

**WARNING:** Monolithic wheels with internal bearings must not be soaked to avoid corroding bearing.

(Note: some staining of the desiccant may remain and is not harmful to performance). Before removing, rapidly run finger across surface of segment to separate polymer strips

for better cleaning action. Rinse dirty solution from segment and remove excess water before reinstalling in wheel.

### Air Seals

Four adjustable diameter seals are provided on each cassette to minimize transfer of air between the counter flowing airstreams.

To adjust diameter seals, loosen diameter seal adjusting screws and back seals away from wheel surface. Rotate wheel clockwise until two opposing spokes are hidden behind the bearing support beam. Using a folded piece of paper as a feeler gauge, position paper between the wheel surface and diameter seals.

Adjust seals towards wheel surface until a slight friction on the feeler gauge (paper) is detected when gauge is moved along the length of the spoke. Retighten adjusting screws and recheck clearance with “feeler” gauge.

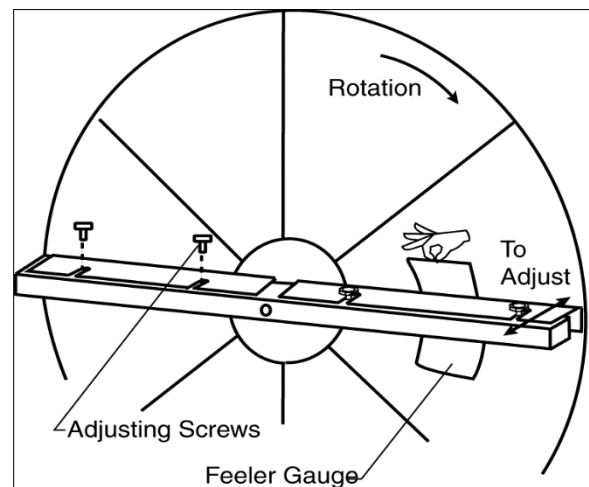

Figure 18 - Diameter Seal Adjustment

### Wheel Drive Components

The wheel drive motor bearings are pre-lubricated and no further lubrication is necessary.

The wheel drive pulley is secured to the drive motor shaft by a combination of either a key or D slot and set screw.

The set screw is secured with removable locktite to prevent loosening. Annually confirm set screw is secure. The wheel drive belt is a urethane stretch belt designed to provide constant tension through the life of the belt. No adjustment is required. Inspect the drive belt annually for proper tracking and tension. A properly tensioned belt will turn the wheel immediately after power is applied with no visible slippage during start-up.

### Installation Considerations

Energy recovery cassettes are incorporated within the design of packaged units, packaged air handlers and energy recovery ventilators. In each case, the following considerations must be addressed:

#### Accessibility

The cassette and all its operative parts; i.e.: motor, belt, pulley, bearings, seals and energy transfer segments must be accessible for service and maintenance. This design requires that adequate clearance be provided outside the enclosure.

#### Orientation & Support

The Energy Recovery Cassette may be mounted in any orientation. However, Care must be taken to make certain that the cassette frame remains flat and the bearing beams are not racked.

To verify, make certain that the distance between wheel rim and bearing beam is the same at each end of the bearing beam, to within .64cm (1/4 of an inch) (dimension A & B). This amount of racking can be compensated for by adjusting the diameter seals.

If greater than .64cm (1/4 of an inch) (dimension C), racking must be corrected to ensure that drive belt will not disengage from wheel.

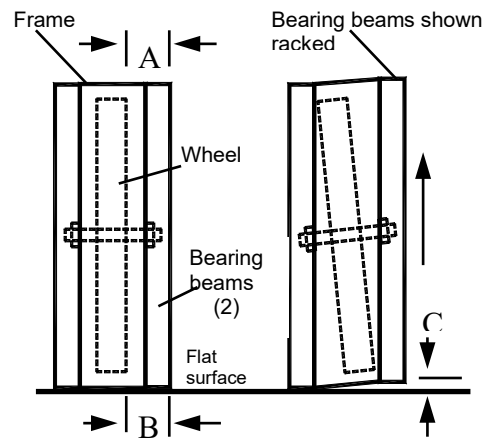

Figure 19 - Avoid Racking of Cassette Frame

### Operation

 <b>CAUTION</b>
<p>Keep hands away from rotating wheel! Contact with rotating wheel can cause physical injury.</p>

#### Startup Procedure

1. By hand, turn wheel clockwise (as viewed from the pulley side), to verify wheel turns freely through 360° rotation.
2. Before applying power to drive motor, confirm wheel segments are fully engaged in wheel frame and segment retainers are completely fastened. (See Segment Installation Diagram).
3. With hands and objects away from moving parts, activate unit and confirm wheel rotation. Wheel rotates clockwise (as viewed from the pulley side).
4. If wheel has difficulty starting, turn power off and inspect for excessive interference between the wheel surface and each of the four (4) diameter seals. To correct, loosen



diameter seal adjusting screws and back adjustable diameter seals away from surface of wheel, apply power to confirm wheel is free to rotate, then re-adjust and tighten hub and diameter seals, as shown in hub seal adjustment diagram.

5. Start and stop wheel several times to confirm seal adjustment and to confirm belt is tracking properly on wheel rim (approximately .64cm [1/4 of an inch] from outer edge of rim).

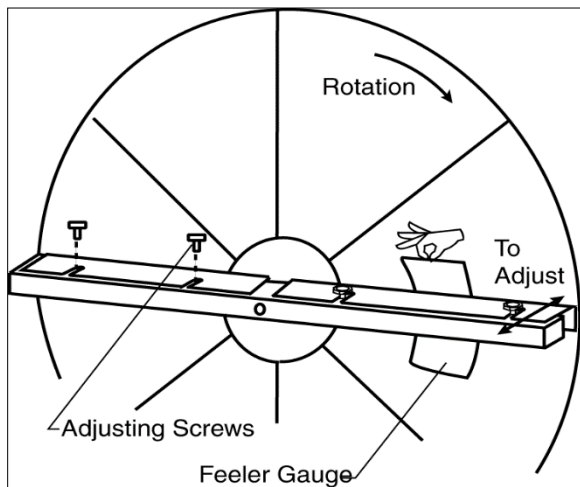

Figure 20 - Diameter Seal Adjustment

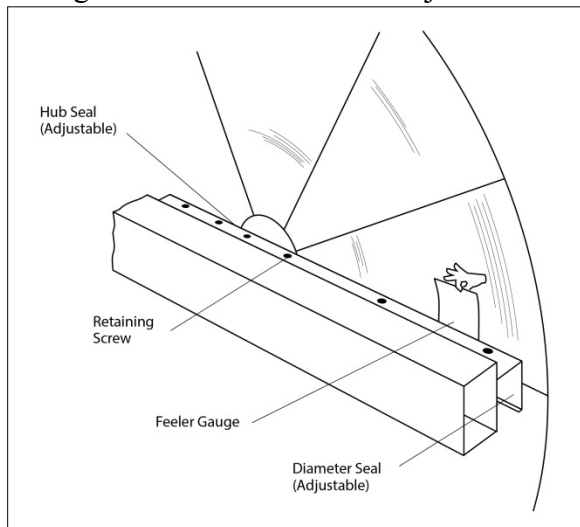

Figure 21 - Hub Seal Adjustment

## Service

### **! CAUTION**

Disconnect electrical power before servicing energy recovery cassette. Always keep hands away from bearing support beam when installing or removing segments. Failure to do so could result in severe injury to fingers or hand.

Wheel segments are secured to the wheel frame by a Segment Retainer which pivots on the wheel rim and is held in place by a Segment Retaining Catch.

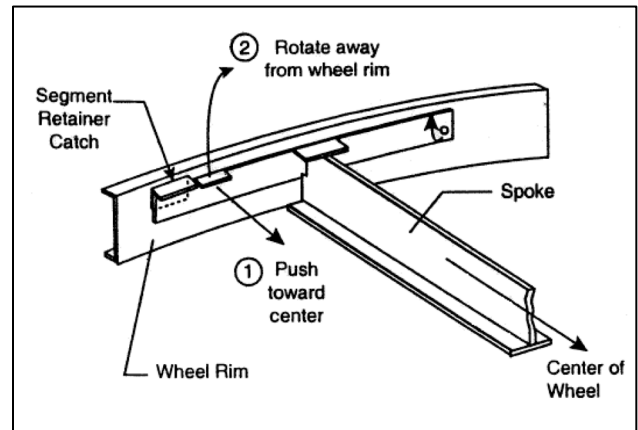

Figure 22 - Segment Retainer

To install wheel segments follow steps one through five below. Reverse procedure for segment removal.

1. Unlock two segment retainers (one on each side of the selected segment opening).

2. With the embedded stiffener facing the motor side, insert the nose of the segment between the hub plates.

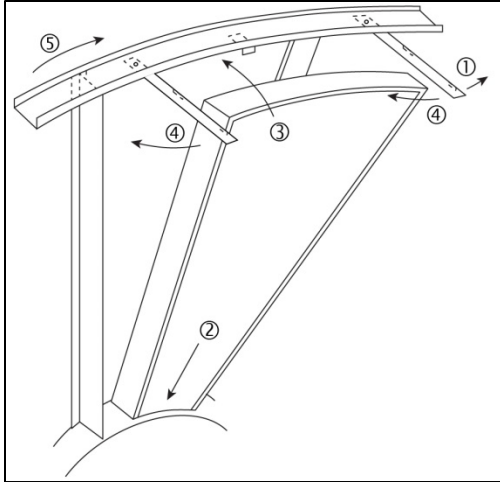

Figure 23 - Segment Installation

3. Holding segment by the two outer corners, press the segment towards the center of the wheel and inwards against the spoke flanges. If hand pressure does not fully seat the segment, insert the flat tip of a screw driver between the wheel rim and outer corners of the segment and apply downward force while guiding the segment into place.

4. Close and latch each Segment Retainer under Segment Retaining Catch.

5. Slowly rotate the wheel 180°. Install the second segment opposite the first for counterbalance. Rotate the two installed segments 90° to balance the wheel while the third segment is installed. Rotate the wheel 180° again to install the fourth segment opposite the third. Repeat this sequence with the remaining four segments.

### Wheel Drive Motor and Pulley Replacement

1. Disconnect power to wheel drive motor.
2. Remove belt from pulley and position temporarily around wheel rim.
3. Loosen set screw in wheel drive pulley using a hex head wrench and remove pulley from motor drive shaft.

4. While supporting weight of drive motor in one hand, loosen and remove (4) mounting bolts.

5. Install replacement motor with hardware kit supplied.

6. Install pulley to dimension as shown and secure set screw to drive shaft.

7. Stretch belt over pulley and engage in groove.

8. Follow start-up procedure.

### Belt Replacement

1. Obtain access to the pulley side bearing access plate if bearing access plates are provided. Remove two bearing access plate retaining screws and the access plate.

2. Using hexagonal wrench, loosen set screw in bearing locking collar. Using light hammer and drift (in drift pin hole) tap collar in the direction of wheel rotation to unlock collar. Remove collar.

3. Using socket wrench with extension, remove two nuts which secure bearing housing to the bearing support beam. Slide bearing from shaft. If not removable by hand, use bearing puller.

4. Form a small loop of belt and pass it through the hole in the bearing support beam. Grasp the belt at the wheel hub and pull the entire belt down.

**Note:** Slight hand pressure against wheel rim will lift weight of wheel from inner race of bearing to assist bearing removal and installation.

**! CAUTION**

Protect hands and belt from possible sharp edges of hole in Bearing Support Beam.

5. Loop the trailing end of the belt over the shaft (belt is partially through the opening).
6. Reinstall the bearing onto the wheel shaft, being careful to engage the two locating pins into the holes in the bearing support beam. Secure the bearing with two self-locking nuts.
7. Install the belts around the wheel and pulley according to the instructions provided with the belt.
8. Reinstall diameter seals or hub seal and tighten retaining screws. Rotate wheel in clockwise direction to determine that wheel rotates freely with slight drag on seals.
9. Reinstall bearing locking collar. Rotate collar by hand in the direction the wheel rotates (see label provided on each cassette for wheel rotation).
10. Lock in position by tapping drift pin hole with hammer and drift. Secure in position by tightening set screw.
11. Reinstall Bearing Access Cover.
12. Apply power to wheel and ensure that the wheel rotates freely without interference.

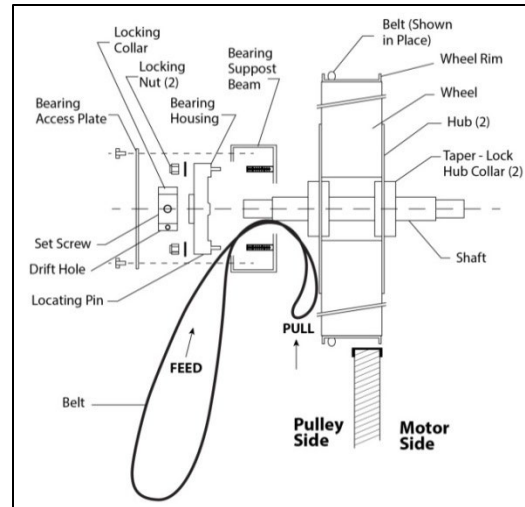

Figure 24 - Belt Replacement

### Startup

(See back of the manual for startup form)

**! WARNING**

Improper installation, adjustment, alteration, service or maintenance can cause property damage, personal injury or loss of life. Startup and service must be performed by a Factory Trained Service Technician. A copy of this IOM must be kept with the unit.

**! WARNING**

Electric shock hazard. Shut off all electrical power to the unit to avoid shock hazard or injury from rotating parts.

During startup, it is necessary to perform routine checks on the performance of the unit. This includes checking of the air flow, the air filters, condenser water flow and refrigerant charge.

## Supply Fans

SB Series units are equipped with direct drive backward curved plenum supply fan assemblies that deliver the air volume specified according to unit size and job requirements.

## Fan Air Flow Adjustment

A specific air volume is delivered by the fans with air volume bands in the blower wheels, Electronically Commutated Motors (ECM), or Variable Frequency Drives (VFD). Field air flow adjustment may be required at startup.

Air volume bands for the wheels are sized according to the unit's air delivery specifications and can also be ordered from the factory for field installation.

## Electrically Commutated Motor Airflow Adjustment

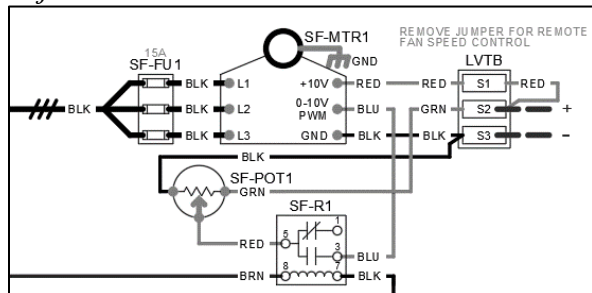

Figure 25 - Typical wiring diagram with EC motor

If the application is for the motor to run at a constant speed, the potentiometer can be utilized without any change. If the application is to vary the motor speed for changing conditions, remove the jumper indicated on the terminal strip (red wire).

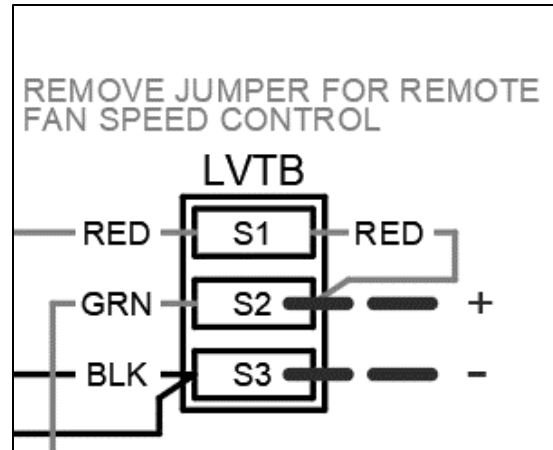

Figure 26 - Shows the jumper that is to be removed (jumped between S1 and S2).

Note, the potentiometer is still active in the electrical loop. Refer to Figure 25.

Set the potentiometer dial for the maximum fan speed for a particular application. Maximum fan speed is determined by the ECat submittal. Typically, this max speed will be the rpm set at the factory.

The fan speed can be modulated using the 0-10 VDC input signal.

To check fan output from the factory, the potentiometer can be dialed to 100%. By sending a 5V signal\*, for instance, the rpm can be measured and this reading can be converted to cubic feet of air moved by the fan.

It is advised that a medium range signal\* be utilized for this procedure. The highest signal sent by the controller must then be determined by adjustment.

## Filters

Do not operate the unit without filters in place. Check unit for correct filter placement during startup. Operation of the equipment

without filters will result in a clogged evaporator coil.

 **CAUTION**

Before completing startup and leaving the unit a complete operating cycle must be observed to verify that all components are functioning properly.

### Adjusting Refrigerant Charge

Adjusting the charge of a system in the field must be based on determination of liquid sub-cooling and evaporator superheat. On a system with a TXV liquid sub-cooling is more representative of the charge than evaporator superheat but both measurements must be taken.

 **CAUTION**

The Clean Air Act of 1990 bans the intentional venting of refrigerant (CFC's and HCFC's) as of July 1, 1992. Approved methods of recovery, recycling or reclaiming must be followed. Fines and/or incarceration may be levied for non-compliance.

### *Before Charging*

Unit being charged must be at or near full load conditions before adjusting the charge. Units equipped with hot gas reheat must be charged with the hot gas reheat valves closed while the unit is in cooling mode to get the proper charge. After charging, operate unit in reheat (dehumidification) mode to check for correct operation.

After adding or removing charge the system must be allowed to stabilize, typically 10-15 minutes, before making any other adjustments.

The type of unit and options determine the ranges for liquid sub-cooling and evaporator superheat. Refer to the tables below when determining the proper sub-cooling.

### *Checking Liquid Sub-Cooling*

Measure the temperature of the liquid line as it leaves the condenser.

Read the gauge pressure at the liquid line close to the point where the temperature was taken. Use liquid line pressure as it will vary from discharge pressure due to condenser pressure drop.

Convert the pressure obtained to a saturated temperature using the appropriate refrigerant temperature-pressure chart.

Subtract the measured liquid line temperature from the saturated temperature to determine the liquid sub-cooling.

Compare calculated sub-cooling to the table below for the appropriate unit type and options.

### *Checking Evaporator Superheat*

Measure the temperature of the suction line close to the compressor.

Read gauge pressure at the suction line close to the compressor.

Convert the pressure obtained to a saturated temperature using the appropriate refrigerant temperature-pressure chart.

Subtract the saturated temperature from the measured suction line temperature to determine the evaporator superheat.

Compare calculated superheat to the table below for the appropriate unit type and options.

**! CAUTION**

**DO NOT OVERCHARGE!**

Refrigerant overcharging leads to excess refrigerant in the condenser coils resulting in elevated compressor discharge pressure.

Table 14 - Acceptable Water-Cooled Refrigeration Circuit Values (Metric)

<b>Water-Cooled Condenser/ Water Source Heat Pump (°C)</b>	
Sub-Cooling	3.3-5.6
Sub-Cooling with Hot Gas Reheat	4.4-6.7
Superheat	4.4-8.3

Table 15 - Acceptable Water-Cooled Refrigeration Circuit Values (Imperial)

<b>Water-Cooled Condenser/ Water Source Heat Pump (°F)</b>	
Sub-Cooling	6-10
Sub-Cooling with Hot Gas Reheat	8-12
Superheat	8-15

**! CAUTION**

Thermal expansion valve must be adjusted to approximately 4.4-8.3 (8-15°F) of suction superheat. Failure to have sufficient superheat will damage the compressor and void the warranty.

*Adjusting Sub-Cooling and Superheat Temperatures*

The system is overcharged if the sub-cooling temperature is too high and the evaporator is fully loaded (low loads on the evaporator

result in increased sub-cooling) and the evaporator superheat is within the temperature range as shown in the table above (high superheat results in increased sub-cooling).

Correct an overcharged system by reducing the amount of refrigerant in the system to lower the sub-cooling.

**! CAUTION**

**DO NOT OVERCHARGE!**

Refrigerant overcharging leads to excess refrigerant in the condenser coils resulting in elevated compressor discharge pressure.

The system is undercharged if the superheat is too high and the sub-cooling is too low

Correct an undercharged system by adding refrigerant to the system to reduce superheat and raise sub-cooling.

If the sub-cooling is correct and the superheat is too high, the TXV may need adjustment to correct the superheat.

**Freeze Stat Startup**

Freeze Stat is an adjustable temperature sensor (-23.3 – 21.1°C [-10 to 70°F]) mounted on the tubing of the first cooling circuit and wired to de-energize all cooling circuits if tubing temperature falls below setpoint. Option is used to prevent freezing of evaporator coil.

*Recommended Setting:* 0 to 1.7°C (32 to 35°F).

Table 16 - R-410A Refrigerant Temperature-Pressure Chart (Metric)

°C	KPA	°C	KPA	°C	KPA	°C	KPA	°C	KPA
<b>-6.7</b>	539.9	<b>8.3</b>	928.8	<b>23.3</b>	1473.5	<b>38.3</b>	2213.3	<b>53.3</b>	3193.8
<b>-6.1</b>	551.6	<b>8.9</b>	946.0	<b>23.9</b>	1496.9	<b>38.9</b>	2245.0	<b>53.9</b>	3235.8
<b>-5.6</b>	564.0	<b>9.4</b>	963.2	<b>24.4</b>	1521.0	<b>39.4</b>	2276.7	<b>54.4</b>	3277.9
<b>-5.0</b>	576.4	<b>10.0</b>	980.5	<b>25.0</b>	1545.2	<b>40.0</b>	2309.1	<b>55.0</b>	3320.6
<b>-4.4</b>	588.8	<b>10.6</b>	998.4	<b>25.6</b>	1570.0	<b>40.6</b>	2341.5	<b>55.6</b>	3363.4
<b>-3.9</b>	601.2	<b>11.1</b>	1016.3	<b>26.1</b>	1594.8	<b>41.1</b>	2374.6	<b>56.1</b>	3406.8
<b>-3.3</b>	614.3	<b>11.7</b>	1034.9	<b>26.7</b>	1619.6	<b>41.7</b>	2408.4	<b>56.7</b>	3450.9
<b>-2.8</b>	627.4	<b>12.2</b>	1053.6	<b>27.2</b>	1645.1	<b>42.2</b>	2442.2	<b>57.2</b>	3495.1
<b>-2.2</b>	640.5	<b>12.8</b>	1072.2	<b>27.8</b>	1670.7	<b>42.8</b>	2476.0	<b>57.8</b>	3539.9
<b>-1.7</b>	654.3	<b>13.3</b>	1090.8	<b>28.3</b>	1696.2	<b>43.3</b>	2510.5	<b>58.3</b>	3585.4
<b>-1.1</b>	667.4	<b>13.9</b>	1110.1	<b>28.9</b>	1722.4	<b>43.9</b>	2544.9	<b>58.9</b>	3630.9
<b>-0.6</b>	681.2	<b>14.4</b>	1129.4	<b>29.4</b>	1749.3	<b>44.4</b>	2580.1	<b>59.4</b>	3677.1
<b>0.0</b>	695.7	<b>15.0</b>	1149.4	<b>30.0</b>	1775.5	<b>45.0</b>	2616.0	<b>60.0</b>	3724.0
<b>0.6</b>	709.5	<b>15.6</b>	1169.4	<b>30.6</b>	1802.4	<b>45.6</b>	2651.8	<b>60.6</b>	3771.6
<b>1.1</b>	724.0	<b>16.1</b>	1189.4	<b>31.1</b>	1829.9	<b>46.1</b>	2688.4	<b>61.1</b>	3819.1
<b>1.7</b>	738.5	<b>16.7</b>	1209.4	<b>31.7</b>	1857.5	<b>46.7</b>	2724.9	<b>61.7</b>	3867.4
<b>2.2</b>	752.9	<b>17.2</b>	1230.1	<b>32.2</b>	1885.8	<b>47.2</b>	2761.4	<b>62.2</b>	3915.7
<b>2.8</b>	768.1	<b>17.8</b>	1251.4	<b>32.8</b>	1914.1	<b>47.8</b>	2798.7	<b>62.8</b>	3965.3
<b>3.3</b>	783.3	<b>18.3</b>	1272.1	<b>33.3</b>	1942.3	<b>48.3</b>	2836.6	<b>63.3</b>	4015.0
<b>3.9</b>	798.4	<b>18.9</b>	1293.5	<b>33.9</b>	1971.3	<b>48.9</b>	2874.5	<b>63.9</b>	4065.3
<b>4.4</b>	814.3	<b>19.4</b>	1314.9	<b>34.4</b>	2000.2	<b>49.4</b>	2913.1	<b>64.4</b>	4115.6
<b>5.0</b>	829.5	<b>20.0</b>	1336.9	<b>35.0</b>	2029.9	<b>50.0</b>	2952.4	<b>65.0</b>	4167.3
<b>5.6</b>	846.0	<b>20.6</b>	1359.0	<b>35.6</b>	2059.5	<b>50.6</b>	2991.7	<b>65.6</b>	4219.1
<b>6.1</b>	861.9	<b>21.1</b>	1381.8	<b>36.1</b>	2089.2	<b>51.1</b>	3031.0		
<b>6.7</b>	878.4	<b>21.7</b>	1403.8	<b>36.7</b>	2120.2	<b>51.7</b>	3071.0		
<b>7.2</b>	895.0	<b>22.2</b>	1427.3	<b>37.2</b>	2150.6	<b>52.2</b>	3111.7		
<b>7.8</b>	911.5	<b>22.8</b>	1450.0	<b>37.8</b>	2181.6	<b>52.8</b>	3153.1		

Table 17 - R-410A Refrigerant Temperature-Pressure Chart (Imperial)

°F	PSIG	°F	PSIG	°F	PSIG	°F	PSIG	°F	PSIG
<b>20</b>	78.3	<b>47</b>	134.7	<b>74</b>	213.7	<b>101</b>	321.0	<b>128</b>	463.2
<b>21</b>	80.0	<b>48</b>	137.2	<b>75</b>	217.1	<b>102</b>	325.6	<b>129</b>	469.3
<b>22</b>	81.8	<b>49</b>	139.7	<b>76</b>	220.6	<b>103</b>	330.2	<b>130</b>	475.4
<b>23</b>	83.6	<b>50</b>	142.2	<b>77</b>	224.1	<b>104</b>	334.9	<b>131</b>	481.6
<b>24</b>	85.4	<b>51</b>	144.8	<b>78</b>	227.7	<b>105</b>	339.6	<b>132</b>	487.8
<b>25</b>	87.2	<b>52</b>	147.4	<b>79</b>	231.3	<b>106</b>	344.4	<b>133</b>	494.1
<b>26</b>	89.1	<b>53</b>	150.1	<b>80</b>	234.9	<b>107</b>	349.3	<b>134</b>	500.5
<b>27</b>	91.0	<b>54</b>	152.8	<b>81</b>	238.6	<b>108</b>	354.2	<b>135</b>	506.9
<b>28</b>	92.9	<b>55</b>	155.5	<b>82</b>	242.3	<b>109</b>	359.1	<b>136</b>	513.4
<b>29</b>	94.9	<b>56</b>	158.2	<b>83</b>	246.0	<b>110</b>	364.1	<b>137</b>	520.0
<b>30</b>	96.8	<b>57</b>	161.0	<b>84</b>	249.8	<b>111</b>	369.1	<b>138</b>	526.6
<b>31</b>	98.8	<b>58</b>	163.8	<b>85</b>	253.7	<b>112</b>	374.2	<b>139</b>	533.3
<b>32</b>	100.9	<b>59</b>	166.7	<b>86</b>	257.5	<b>113</b>	379.4	<b>140</b>	540.1
<b>33</b>	102.9	<b>60</b>	169.6	<b>87</b>	261.4	<b>114</b>	384.6	<b>141</b>	547.0
<b>34</b>	105.0	<b>61</b>	172.5	<b>88</b>	265.4	<b>115</b>	389.9	<b>142</b>	553.9
<b>35</b>	107.1	<b>62</b>	175.4	<b>89</b>	269.4	<b>116</b>	395.2	<b>143</b>	560.9
<b>36</b>	109.2	<b>63</b>	178.4	<b>90</b>	273.5	<b>117</b>	400.5	<b>144</b>	567.9
<b>37</b>	111.4	<b>64</b>	181.5	<b>91</b>	277.6	<b>118</b>	405.9	<b>145</b>	575.1
<b>38</b>	113.6	<b>65</b>	184.5	<b>92</b>	281.7	<b>119</b>	411.4	<b>146</b>	582.3
<b>39</b>	115.8	<b>66</b>	187.6	<b>93</b>	285.9	<b>120</b>	416.9	<b>147</b>	589.6
<b>40</b>	118.1	<b>67</b>	190.7	<b>94</b>	290.1	<b>121</b>	422.5	<b>148</b>	596.9
<b>41</b>	120.3	<b>68</b>	193.9	<b>95</b>	294.4	<b>122</b>	428.2	<b>149</b>	604.4
<b>42</b>	122.7	<b>69</b>	197.1	<b>96</b>	298.7	<b>123</b>	433.9	<b>150</b>	611.9
<b>43</b>	125.0	<b>70</b>	200.4	<b>97</b>	303.0	<b>124</b>	439.6		
<b>44</b>	127.4	<b>71</b>	203.6	<b>98</b>	307.5	<b>125</b>	445.4		
<b>45</b>	129.8	<b>72</b>	207.0	<b>99</b>	311.9	<b>126</b>	451.3		
<b>46</b>	132.2	<b>73</b>	210.3	<b>100</b>	316.4	<b>127</b>	457.3		



## Operation

Unit operations must be controlled with thermostat or unit controller, never at the main power supply, except for emergency or complete shutdown of the unit.

### Packaged DX Cooling Operation and Control

When a call for cooling is made the supply fan motors and compressors will energize.

 **WARNING**

**COMPRESSOR CYCLING**

**3 MINUTE MINIMUM OFF TIME**  
To prevent motor overheating compressors must cycle off for a minimum of 3 minutes.

**5 MINUTE MINIMUM ON TIME**  
To maintain the proper oil level compressors must cycle on for a minimum of 5 minutes.

The cycle rate must not exceed 7 starts per hour.

### Electric Heating Operation

When a call for heating (G and W1, W2, etc.) is made the supply fan motors and electric resistance heaters will energize. Heating is accomplished by passing electrical current through a specified amount of resistance heaters which will produce the required heat.

On a fault condition the main limit located in the supply air or the auxiliary limit located downstream the supply blower will remove power from all contactors.

### Steam or Hot Water Preheating Operation

Valve control for steam and hot water heating coils are by others. Heating is accomplished

by passing steam or hot water through the steam or hot water coil assembly.

## Maintenance

(See back of the manual for maintenance log.)

At least once each year, a qualified service technician must check out the unit. Supply fans, evaporator coils and air filters must be inspected monthly.

 **WARNING**

Improper installation, adjustment, alteration, service or maintenance can cause property damage, personal injury or loss of life. Installation and service must be performed by a qualified technician. A copy of this IOM must be kept with the unit.

Periodically during operation, it is necessary to perform routine service checks on the performance of the unit. This includes checking of the air flow, the air filters, condenser water flow and refrigerant charge.

See Startup section for information on air flow adjustment and refrigerant charge adjustment.

### DX Cooling

Set unit controls to cooling mode of operation with supply fans on. Check the fans for correct operating direction, amperage and voltage. Check compressor operation, rotation, amperage and voltage to the unit nameplate (check the amperage on the load side of the compressor contactor).

### Condensate Drain Pans

Drain pans will have moisture present and require periodic cleaning to prevent microbial growth. Cleaning of the drain pans will also prevent any possible plugging of the

drain lines and overflow of the pan itself. Cleaning of the drain pans and inside of the unit must be done only by qualified personnel.

### E-Coated Coil Cleaning

Documented routine cleaning of e-coated coils is required to maintain coating warranty coverage for condenser coils. E-Coated Coil Maintenance Record sheet is provided in this document.

#### WARNING

Electric shock hazard. Shut off all electrical power to the unit to avoid shock hazard or injury from rotating parts.

Remove surface loaded fibers or dirt prior to water rinse to prevent restriction of airflow. If unable to back wash the side of the coil opposite of the coils entering air side, then remove surface loaded fibers or dirt with a vacuum cleaner. If a vacuum cleaner is not available, a *soft non-metallic* bristle brush may be used. In either case, the tool must be applied in the direction of the fins. Coil surfaces can be easily damaged (fin edges bent over) if the tool is applied across the fins.

Use of a water stream, such as a garden hose, against a surface loaded coil will drive the fibers, dirt and salts into the coil. This will make cleaning efforts more difficult. Surface loaded fibers must be completely removed prior to using low velocity clean water rinse.

A *monthly* clean water rinse is recommended for coils that are applied in coastal or industrial environments to help to remove chlorides, dirt, and debris. It is very important when rinsing, that water temperature is less than 130°F and pressure is less than 100 psig to avoid damaging the fin edges. An elevated water temperature (not to exceed 130°F) will reduce surface tension, increasing the ability to remove chlorides and dirt.

#### CAUTION

High velocity water from a pressure washer or compressed air must only be used at a very low pressure to prevent fin and/or coil damages. The force of the water or air jet may bend the fin edges and increase airside pressure drop. Reduced unit performance or nuisance unit shutdowns may occur.

*Quarterly cleaning is essential to extend the life of an e-coated coil and is required to maintain coating warranty coverage.*

Coil cleaning must be part of the unit's regularly scheduled maintenance procedures. Failure to clean an e-coated coil will void the warranty and may result in reduced efficiency and durability.

#### CAUTION

Harsh chemicals, household bleach, or acid cleaners must not be used to clean outdoor or indoor e-coated coils. These cleaners can be very difficult to rinse out of the coil and can accelerate corrosion and attack the E-coating. If there is dirt below the surface of the coil, use the recommended coil cleaners.

For routine quarterly cleaning, first clean the coil with the below approved coil cleaner. After cleaning the coils with the approved cleaning agent, use the approved chloride remover to remove soluble salts and revitalize the unit.

### Recommended Coil Cleaner

The following cleaning agent, when used in accordance with the manufacturer's directions on the container for proper mixing and cleaning, has been approved for use on

e-coated coils to remove mold, mildew, dust, soot, greasy residue, lint, and other particulate:

Enviro-Coil Cleaner: AAON PN: V82540

GulfClean™ Coil Cleaner:  
AAON PN: G074480

### Recommended Chloride Remover

GulfClean Salt Reducer™ :  
AAON PN: G074490

GulfClean Salt Reducer™ is used to remove soluble salts from the e-coated coil, follow the manufacturer's instructions. This product is not intended for use as a degreaser. Any grease or oil film must first be removed with GulfClean™ Coil Cleaner.

Remove Barrier - First ensure the power to the unit is off and locked out. Clean the area around the unit if needed to ensure leaves, grass or loose debris will not be blown into the coil. Soluble salts adhere themselves to the substrate. For the effective use of this product, the product must be able to come in contact with the salts. These salts may be beneath any soils, grease or dirt; therefore, these barriers must be removed prior to application of this product. As in all surface preparation, the best work yields the best results.

Application- Apply GulfClean™ Coil Cleaner directly onto the substrate. Sufficient product must be applied uniformly across the substrate to thoroughly wet out surface, with no areas missed. This may be accomplished by use of a pump-up sprayer or conventional spray gun. Apply the cleaner to unit interior air exiting side coil surfaces first. Work in sections/panels moving side to side and from top to bottom. Allow the cleaning solution to soak for 5 to 10 minutes. Then move on to the exterior using the same method.

Rinse - Using pressurized potable water such as a garden hose, (< 689.5 kpa [100 psi]), rinse the coils and continue to always work in sections/panels.

Continue until all coil areas on the inside of the unit have been rinsed. **Note: Coils must always be cleaned / back flushed, opposite of airflow to prevent impacting the dirt into the coil.**

Repeat these steps with GulfClean™ Salt Reducer. When finished replace all panels and tops that were removed.

### Supply Fans

#### CAUTION

Blower wheels must be inspected for excessive dust build up periodically and cleaned if required. Excessive dust build up on blower wheels may cause an unbalanced state; leading to vibration and/or component failure. Damages due to excessive dust build up will not be covered under factory warranty.

#### WARNING

Electric shock hazard. Shut off all electrical power to the unit to avoid shock hazard or injury from rotating parts.

### Supply Fan Lubrication

All original blower motors and bearings are furnished with factory lubrication. Some applications will require that bearings be re-lubricated periodically. The schedule will depend on the operating duty, temperature variations or other severe atmospheric conditions.

Bearings must be re-lubricated when at normal operating temperatures, but not running. Rotate the fan shaft by hand and add only enough grease to purge the seals. DO NOT OVERLUBRICATE.

**Recommended greases are:**  
SHELL OIL - DOLIUM R  
CHEVRON OIL - SRI No. 2  
TEXACO INC. - PREMIUM R

### Filter Replacement

Monthly filter inspection is required to maintain optimum unit efficiency.

**WARNING**

Electric shock hazard. Shut off all electrical power to the unit to avoid shock hazard or injury from rotating parts.

Filter media must be replaced monthly. Filters are located upstream of the evaporator coil. Open access panel and pull filters straight out to inspect all of the filters. Replace filters with the size indicated on each filter. Arrow on the replacement filters must point towards the blower.

### Phase and Brownout Protection Module



The DPM is a Digital Phase Monitor that monitors line voltages from 200VAC to 240VAC 1 $\phi$  and 200VAC to 600VAC 3 $\phi$ . The DPM is 50/60 Hz self-sensing. DPM must be wired according to unit specific wiring diagram include in the control compartment

When the DPM is connected to the line voltage, it will monitor the line and if everything is within the setup parameters, the output contacts will be activated. If the line voltages fall outside the setup parameters, the output relay will be de-energized after the trip delay.

Once the line voltages recover, the DPM will re-energize the output relay after the restart time delay. All settings and the last 4 faults are retained, even if there is a complete loss of power.

### DPM Setup Procedure

With the supply voltage active to the module, you can setup all of the DPM's settings without the line voltage connected.

To change the setpoint parameters use the right arrow key to advance forward through the setpoint parameters and the left arrow to backup if needed. When each parameter is displayed use the up/down keys to change and set the parameter.

After adjustments are made or if no adjustments are made it will take 2 to 4 minutes before the DPM energizes the output relay unless there is an out of tolerance issue with the incoming line voltage.

**Recommended Default Set-up**

Line Voltage	460VAC, 3Ø
Over & Undervoltage	±10%
Trip Time Delay	5 Seconds
Re-Start Time Delay	2 Minutes
Phase Imbalance	5%

## Screens

### Manufacturer's Screen

R-K Electronics  
DPM v0.0.00

### Average Voltage Screen

VAvg	Imb	Hz	
460	0	60	off

**Default – the default screen shows the real time voltage detected in each of the 3 phases:**

A-B	B-C	C-A	
460	459	461	ON

### Voltage Selection Screen (Vertical Format) Default = 460V, 3Ø

200, 1Ø; 208, 1Ø; 220, 1Ø; 230, 1Ø; 240, 1Ø;  
200, 3Ø; 208, 3Ø; 220, 3Ø; 230, 3Ø; 240, 3Ø; 380, 3Ø; 415, 3Ø; 440, 3Ø;  
460, 3Ø; 480 3Ø; 575, 3Ø; 600, 3Ø;

### Over/Under voltage Percentage Screen (Vertical Format) Default = 10%

7% 8% 9% 10% 11% 12% 13% 14% & 15%

### Trip Time Delay Screen (Vertical Format) Default = 5 sec

2S, 3S, 4S, 5S, 6S, 27S, 8S, 9S & 10S

### Re-Start Time Delay Screen (Vertical Format) Default = 2 sec

Manual, 2S, 3S, 4S, 5S, 6S, 7S, 8S, 9S, 10S, 30S, 1M, 2M, 3M & 4M

### Phase Imbalance Percentage Screen (Vertical Format) Default = 5%

3% 4% 5% 6% 7% 8% 9% & 10%

### Fault Screen (Vertical Format)

“0” most recent faults, “1” previous fault “2” third oldest fault & “3” fourth oldest fault.

### Fault Words:

“Phase a Loss”	(There is no voltage sensed on 3-L1/S)
“Voltage Low”	(Average line voltage is less than selected Undervoltage Percentage)
“Voltage High”	(Average line voltage is more than selected Overvoltage Percentage)
“Imbalance”	(One phase is lower than the average voltage by more than the Imbalance percentage)
“Phase Loss	(One phase is more than 30% below the Line Voltage selection)
“Bad Rotation”	(The phase rotation sequence is reversed)
“Bad Freq”	(Line frequency out of allowable range of 45 to 65 Hz)

## Filter Information

Table 18 - 3-5 ton (B Cabinet) Pre and Unit Filters

<b>Feature 6A</b>	<b>Quantity/Size</b>	<b>Type</b>
0	No Pre Filters	
A	(1) 24" x 24" x 2"	Pleated, MERV 8
<b>Feature 6B</b>	<b>Quantity/Size</b>	<b>Type</b>
0	No Standard Filters	
A	(1) 24" x 24" x 2"	Pleated, MERV 8
B	(1) 24" x 24" x 4"	Pleated, MERV 8
C		Pleated, MERV 11
D		Pleated, MERV 13
E		Pleated, MERV 14
F		Carbon

Table 19 - 6-10 ton (C Cabinet) Pre and Unit Filters

<b>Feature 6A</b>	<b>Quantity/Size</b>	<b>Type</b>
0	No Pre Filters	
A	(4) 16" x 20" x 2"	Pleated, MERV 8
<b>Feature 6B</b>	<b>Quantity/Size</b>	<b>Type</b>
0	No Standard Filters	
A	(4) 16" x 20" x 2"	Pleated, MERV 8
B	(4) 16" x 20" x 4"	Pleated, MERV 8
C		Pleated, MERV 11
D		Pleated, MERV 13
E		Pleated, MERV 14
F		Carbon

Table 20 - 14-18 ton (D Cabinet) Pre and Unit Filters

<b>Feature 6A</b>	<b>Quantity/Size</b>	<b>Type</b>
0	No Pre Filters	
A	(4) 18" x 24" x 2"	Pleated, MERV 8
<b>Feature 6B</b>	<b>Quantity/Size</b>	<b>Type</b>
0	No Standard Filters	
A	(4) 18" x 24" x 2"	Pleated, MERV 8
B	(4) 18" x 24" x 4"	Pleated, MERV 8
C		Pleated, MERV 11
D		Pleated, MERV 13
E		Pleated, MERV 14
F		Carbon

Table 21 - 3-5 ton (B Cabinet) Mixing Box Filters

<b>Feature 6A</b>	<b>Quantity/Size</b>	<b>Type</b>
A	(1) 24" x 24" x 2" (located in the mixing box)	2" Pleated, MERV 8 Pre-Filters
<b>Feature 6B</b>	<b>Quantity/Size</b>	<b>Type</b>
G	(1) 24" x 24" x 4" (located in the mixing box) and (1) 24" x 24" x 4" (located in the unit)	Pleated, MERV 11 and Carbon
H		Pleated, MERV 13 and Carbon
J		Pleated, MERV 14 and Carbon
K		Pleated, MERV 11 and Pleated, MERV 13
L		Pleated, MERV 11 and Pleated, MERV 14

Table 22 - 6-10 ton (C Cabinet) Mixing Box Filters

<b>Feature 6A</b>	<b>Quantity/Size</b>	<b>Type</b>
A	(4) 16" x 20" x 2" (located in the mixing box)	2" Pleated, MERV 8 Pre-Filters
<b>Feature 6B</b>	<b>Quantity/Size</b>	<b>Type</b>
G	(4) 16" x 20" x 4" (located in the mixing box) and (4) 16" x 20" x 4" (located in the unit)	Pleated, MERV 11 and Carbon
H		Pleated, MERV 13 and Carbon
J		Pleated, MERV 14 and Carbon
K		Pleated, MERV 11 and Pleated, MERV 13
L		Pleated, MERV 11 and Pleated, MERV 14



Table 23 - 14-18 ton (D Cabinet) Mixing Box Filters

<b>Feature 6A</b>	<b>Quantity/Size</b>	<b>Type</b>
A	(4) 18" x 24" x 2" (located in the mixing box)	2" Pleated, MERV 8 Pre-Filters
<b>Feature 6B</b>	<b>Quantity/Size</b>	<b>Type</b>
G	(4) 18" x 24" x 4" (located in the mixing box) and (4) 18" x 24" x 4" (located in the unit)	Pleated, MERV 11 and Carbon
H		Pleated, MERV 13 and Carbon
J		Pleated, MERV 14 and Carbon
K		Pleated, MERV 11 and Pleated, MERV 13
L		Pleated, MERV 11 and Pleated, MERV 14

**Replacement Parts**

Parts for AAON equipment may be obtained from your local AAON representative. Reference the unit serial number and part number when ordering parts.

**AAON Warranty, Service, and Parts Department**

2424 S. Yukon Ave.  
Tulsa, OK 74107  
Ph: 918-382-6450  
Fax: 918-382-6364  
www.aon.com

**Filter Conversion Table**

<b>Inches</b>	<b>Centimeters</b>
[16 x 20 x 2]	[40.6 x 50.8 x 5.1]
[16 x 20 x 4]	[40.6 x 50.8 x 10.2]
[18 x 24 x 2]	[45.7 x 61 x 5.1]
[18 x 24 x 4]	[45.7 x 61 x 10.2]
[20 x 24 x 2]	[50.8 x 61 x 5.1]
[20 x 24 x 4]	[50.8 x 61 x 10.2]

**Note:** Before calling, technician should have model and serial number of the unit available for the service department to help answer questions regarding the unit.

**Warranty:** Refer to the Limited Warranty Certificate for the unit warranty details. Contact your AAON representative for a unit specific copy of the certificate for your serial number



## Limited Warranty Certificate

### GENERAL CONDITIONS

AAON, Inc. (hereinafter referred to as "AAON") warrants this AAON equipment, as identified hereon, to be free of defects in material and workmanship under normal use, service, and maintenance. Our obligations under this warranty must be limited to repairing or replacing the defective part, or parts, which in our judgment show evidence of such defects. AAON is not liable for labor charges and other costs incurred for removing, shipping, handling or transporting defective part, or parts, or for shipping, handling, transporting, or installing repaired or replacement part, or parts.

The limited warranty is effective one (1) year from date of **original installation**, or eighteen (18) months from date of original shipment from the factory, whichever occurs first and covers all parts and components in this AAON equipment excluding air filters, belts, refrigerant moisture driers, and lost refrigerant, which are not included in any part of this limited warranty. The replacement part, or parts, assume only the unused portion of the original limited warranty and are shipped f.o.b. from the factory and freight prepaid by the factory.

The limited warranty is effective for products manufactured at the Tulsa, Oklahoma or Longview, Texas facility.

THIS LIMITED WARRANTY ONLY APPLIES WHEN THE **ORIGINAL MODEL NUMBER AND SERIAL NUMBER** OF THE AAON UNIT ARE GIVEN AT TIME OF REQUEST FOR REPLACEMENT PART, OR PARTS. DEFECTIVE PART, OR PARTS, MUST BE RETURNED **PREPAID**, WITH ITS ASSIGNED RETURN MATERIAL TAG, WITHIN FOURTEEN (14) DAYS OF RECEIPT OF THE REPLACEMENT PART, OR PARTS.

### EXTENDED LIMITED WARRANTY ON COMPRESSORS INCLUDED IN SINGLE PACKAGE EQUIPMENT (NOT INCLUDING CHILLERS OR WH/WV); OPTIONAL ON OTHER EQUIPMENT

For the second through the fifth year from date of **shipment**, we further agree to repair or replace the fully hermetic compressor, at our option, for the **original purchaser-user only**. The repaired or replacement fully hermetic compressor will be supplied f.o.b. the factory, freight **prepaid and add**, providing the defective fully hermetic compressor is returned **prepaid by the customer**, and is proven to be inoperative due to defects in materials or workmanship. This extended limited warranty covers **only** the fully hermetic compressor and **does not include** any labor charges, or other additional costs incurred for removing, shipping, handling, transporting, or replacing the defective fully hermetic compressor. It also **does not include** additional costs incurred for shipping, handling, or transporting of electric controls such as relays, capacitors, pressure controls, or fan-motor assemblies, condensers, receivers, etc, which carry the standard **one-year limited warranty**.

### EXTENDED LIMITED WARRANTY OF WH/WV PRODUCTS

The WH/WV limited warranty is effective five (5) years from date of original installation. If installation date cannot be verified, limited warranty is effective five (5) years from date of equipment manufacture at the factory. Warranty covers all parts and components, including compressors, in this AAON equipment except those excluded in the general conditions.

### EXTENDED LIMITED WARRANTY OF RQ PRODUCTS

The RQ limited warranty is effective two (2) years from date of original **shipment** from the factory and covers all parts and components in this AAON equipment except those excluded in the general conditions.

### FOR OPTIONAL TWO YEAR EXTENDED LIMITED WARRANTY OF RN PRODUCTS

The limited warranty is effective two (2) years from date of original **shipment** from the factory and covers all parts and components in this AAON equipment except those excluded in the general conditions.

### FOR OPTIONAL FIVE YEAR EXTENDED LIMITED WARRANTY OF RN OR RQ PRODUCTS

The limited warranty is effective five (5) years from date of original **shipment** from the factory and covers all parts and components in this AAON equipment except those excluded in the general conditions.

### FOR OPTIONAL TEN YEAR EXTENDED LIMITED WARRANTY OF RN OR RQ PRODUCTS

The limited warranty is effective ten (10) years from date of original **shipment** from the factory and covers all parts and components in this AAON equipment except those excluded in the general conditions.

### FOR OPTIONAL FIVE YEAR EXTENDED LIMITED WARRANTY OF RN OR RQ ECONOMIZER WITH FAULT DETECTION AND DIAGNOSTICS

For the second through fifth year from date of shipment, we further warrant the economizer damper assembly against failure due to defects in materials and workmanship for the original purchaser-user only.

### EXTENDED LIMITED WARRANTY OF GAS FIRED HEAT EXCHANGERS

#### FOR RQ OR RN ALUMINIZED STEEL HEAT EXCHANGERS

For the second through the fifteenth year from date of **shipment**, we further warrant the steel heat exchanger against failure due to defects in materials and workmanship for the **original purchaser-user only**.

#### FOR RQ, RN, OR RZ STAINLESS STEEL HEAT EXCHANGERS

For the second through the twenty-fifth year from date of **shipment**, we further warrant the stainless steel heat exchanger against failure due to defects in materials and workmanship for the **original purchaser-user only**.

#### FOR RL SERIES HEAT EXCHANGERS

For the second through the tenth year from date of original installation, we further warrant the steel heat exchanger against failure due to defects in materials and workmanship for the original purchaser-user only, in accordance with the following: For the first five (5) years from date of shipment, we agree to repair or replace the heat exchanger, at our option, for the original purchaser-user only; during the sixth year, we will charge 50% of the current trade price for repaired or replacement steel heat exchanger, as the case may be, during the seventh year, 60%, during the eighth year, 70% during the ninth year, 80% and during the tenth year, 90%.

In all cases, the repaired or replacement heat exchanger will be supplied f.o.b. our factory, freight prepaid, providing the defective heat exchanger is returned **prepaid**, and if it is proved to be inoperative due to defects in materials and workmanship. This extended limited warranty covers **only** the heat exchanger and **does not include** labor charges, or other costs incurred for removing, shipping, handling, transporting, or installing repaired replacement heat exchanger. This extend limited warranty **does not apply** where the furnace has been operated in an atmosphere contaminated by chlorine, fluorine, or any other damaging chemical compounds.

### FOR OPTIONAL FIVE YEAR EXTENDED LIMITED WARRANTY OF COIL COATING

For the second through fifth year from date of shipment, we further warrant the coating of e-coated coils on the equipment against failure due to defects in materials and workmanship for the original purchaser-user only. Coil cleaning, maintenance, and record keeping must be followed according to the unit Installation, Operation and Maintenance Manual to maintain warranty.



## Limited Warranty Certificate

### OTHER CONDITIONS

This warranty **does not cover** any AAON unit or part thereof which has been subject to accident, negligence, damages in transit, misuse or abuse, or which has been **tampered with or altered in any way**, or which has not been installed, operated, serviced and maintained in accordance with our instructions, or which has been installed outside of the Continental United States or Canada, or on which the serial number or identification number has been altered, defaced, or removed. AAON will not be responsible for failure of the unit to start due to voltage conditions, blown fuses, open circuit breakers, or other damages due to the inadequacy or interruption of electric service.

This warranty **does not cover** equipment containing a water-to-refrigerant heat exchanger for any damage resulting from freezing, fouling, corrosion or clogging.

AAON must not be liable for any default or delay in performance hereunder, caused by a contingency beyond its control, including governmental restrictions or restraint, strikes, short or reduced supply of raw materials or parts, floods, winds, fire, lightning strikes, or any other acts of God.

### DISCLAIMERS OF WARRANTIES

THIS WARRANTY IS EXCLUSIVE AND IS IN LIEU OF ANY WARRANTY OF MERCHANTABILITY, FITNESS FOR A PARTICULAR PURPOSE OR OTHER WARRANTY OF QUALITY, WHETHER EXPRESS OR IMPLIED, EXCEPT OF TITLE AND AGAINST PATENT INFRINGEMENT, CORRECTION OF NON-CONFORMITIES ARE LIMITED TO REPAIR OR REPLACEMENT OF THE DEFECTIVE PART OR PARTS, AT SELLER'S OPTION, WHICH MUST CONSTITUTE FULFILLMENT OF ALL TORT OR OTHERWISE IT IS EXPRESSLY UNDERSTOOD THAT AAON MUST NOT BE LIABLE FOR ANY CONSEQUENTIAL OR INCIDENTAL DAMAGES. AAON MUST NOT UNDER ANY CIRCUMSTANCES BE LIABLE FOR SPECIAL, INCIDENTAL OR CONSEQUENTIAL DAMAGES, SUCH AS, BUT NOT LIMITED TO DAMAGES OR LOSS OF OTHER PROPERTY OR EQUIPMENT, LOSS OF PROFITS OR REVENUE, COST OF CAPITAL, COST OF PURCHASED OR REPLACEMENT GOODS, OR CLAIMS OF BUYER OR USER FOR SERVICE INTERRUPTIONS. THE REMEDIES OF THE BUYER SET FORTH HEREIN ARE EXCLUSIVE, AND THE LIABILITY OF AAON WITH RESPECT TO ANY CONTRACT, OR ANYTHING DONE IN CONNECTION THEREWITH SUCH AS THE PERFORMANCE OR BREACH THEREFORE, OR FROM THE MANUFACTURE, SALE, DELIVERY, RESALE, INSTALLATION, OR USE OF ANY GOODS COVERED BY OR FURNISHED UNDER THIS CONTRACT WHETHER ARISING OUT OF CONTRACT, NEGLIGENCE, STRICT TORT, OR UNDER ANY WARRANTY, OR OTHERWISE, MUST NOT EXCEPT AS EXPRESSLY PROVIDED HEREIN, EXCEED THE PRICE OF THE GOODS UPON WHICH SUCH LIABILITY IS BASED.

WITH RESPECT TO THE GOODS SOLD, THE BUYER HEREBY WAIVES ALL LIABILITY ARISING FROM STATUTE, LAW, STRICT LIABILITY IN TORT, OR OTHERWISE, INCLUDING WITHOUT LIMITATION ANY OBLIGATION OF AAON WITH RESPECT TO CONSEQUENTIAL OR INCIDENTAL DAMAGES AND WHETHER OR NOT OCCASIONED BY AAON NEGLIGENCE. TIME LIMIT ON COMMENCING LEGAL ACTIONS: AN ACTION FOR BREACH OF THIS CONTRACT FOR GOOD SOLD OR ANY OTHER ACTION OTHERWISE ARISING OUT OF THIS CONTRACT, MUST BE COMMENCED WITHIN ONE (1) YEAR FROM THE DATE, THE RIGHT, CLAIM, DEMAND OR CAUSE OF ACTION MUST FIRST OCCUR, OR BE BARRED FOREVER.

### SEVERABILITY

IF ANY PROVISION OR CAUSE OF THIS CONTRACT OR APPLICATION THEREOF TO ANY PERSON OR CIRCUMSTANCES IS HELD INVALID OR UNCONSCIONABLE SUCH INVALIDITY OR UNCONSCIONABILITY MUST NOT AFFECT OTHER PROVISIONS OR APPLICATIONS OF THE CONTRACT WHICH CAN BE GIVEN EFFECT WITHOUT THE INVALID OR UNCONSCIONABLE PROVISIONS OF THE CONTRACT ARE DECLARED BE SEVERABLE.

### EQUIPMENT INFORMATION (REQUIRED)

<b>Job Name:</b>	Click or tap here to	<b>Sales Order Number:</b>	Click or tap here to enter text.	<b>Unit Tag:</b>	Click or tap here to enter text.	<b>Date of Shipment:</b>	Click or tap here to enter text.
<b>Serial Number:</b>	Click or tap here to enter text.	<b>Unit Model Number:</b>	Click or tap here to enter text.				

## Appendix A - Heat Exchanger Corrosion Resistance

The resistance guide below provides the corrosion resistance of stainless steel type AISI 316 and pure Copper (99.9%) in water, to a number of important chemical factors. The actual corrosion is a very complex process influenced by many different factors in combination.

Explanations: + Good resistance under normal conditions

0 Corrosion problems may occur especially when more factors are valued 0

- Use is not recommended

Water Containing	Concentration (mg/l or ppm)	Time Limits - Analyze Before	AISI 316	SMO 254	Copper Alloy	Nickel Alloy
Alkalinity (HCO <sub>3</sub> <sup>-</sup> )	< 70	Within 24 Hours	+	+	0	+
	70-300		+	+	+	+
	> 300		+	+	0/+	+
Sulfate (SO <sub>4</sub> <sup>2-</sup> )	< 70	No Limit	+	+	+	+
	70-300		+	+	0/-	+
	> 300		0	0	-	+
HCO <sub>3</sub> <sup>-</sup> / SO <sub>4</sub> <sup>2-</sup>	> 1.0	No Limit	+	+	+	+
	< 1.0		+	+	0/-	+
Electrical Conductivity	< 10µS/cm	No Limit	+	+	0	+
	10-500 µS/cm		+	+	+	+
	> 500 µS/cm		+	+	0	+
pH	< 6.0	Within 24 Hours	0	0	0	+
	6.0-7.5		0/+	+	0	+
	7.5-9.0		+	+	+	+
	> 9.0		+	+	0	+
Ammonium (NH <sub>4</sub> <sup>+</sup> )	< 2	Within 24 Hours	+	+	+	+
	2-20		+	+	0	+
	> 20		+	+	-	+
Chlorides (Cl) <sup>*</sup>	< 300	No Limit	+	+	+	+
	> 300		0	+	0/+	+
Free Chlorine (Cl <sub>2</sub> )	< 1	Within 5 Hours	+	+	+	+
	1-5		+	+	0	+
	> 5		0/+	+	0/-	+
Hydrogen Sulfide (H <sub>2</sub> S)	< 0.05	No Limit	+	+	+	+
	> 0.05		+	+	0/-	+
Free (aggressive) Carbon Dioxide (CO <sub>2</sub> )	< 5	No Limit	+	+	+	+
	5-20		+	+	0	+
	> 20		+	+	-	+

\*See Also Chloride Content Table

Water Containing	Concentration (mg/l or ppm)	Time Limits - Analyze Before	AISI 316	SMO 254	Copper Alloy	Nickel Alloy
Total Hardness (°dH)	4.0-8.5	No Limit	+	+	+	+
Nitrate (NO <sub>3</sub> )	< 100	No Limit	+	+	+	+
	> 100		+	+	0	+
Iron (Fe)	< 0.2	No Limit	+	+	+	+
	> 0.2		+	+	0	+
Aluminum (Al)	< 0.2	No Limit	+	+	+	+
	> 0.2		+	+	0	+
Manganese (Mn)	< 0.1	No Limit	+	+	+	+
	> 0.1		+	+	0	+

#### Chloride Content

Chloride Content	Maximum Temperature			
	60°C (140°F)	80°C (176°F)	120°C (248°F)	130°C (266°F)
= 10 ppm	SS 304	SS 304	SS 304	SS 316
= 25 ppm	SS 304	SS 304	SS 316	SS 316
= 50 ppm	SS 304	SS 316	SS 316	Ti / SMO 254
= 80 ppm	SS 316	SS 316	SS 316	Ti / SMO 254
= 150 ppm	SS 316	SS 316	Ti / SMO 254	Ti / SMO 254
= 300 ppm	SS 316	Ti / SMO 254	Ti / SMO 254	Ti / SMO 254
> 300 ppm	Ti / SMO 254	Ti / SMO 254	Ti / SMO 254	Ti / SMO 254

## SB Series Startup Form

Job Name: _____	Date: _____
Address: _____	
Model Number: _____	
Serial Number: _____	Tag: _____
Startup Contractor: _____	
Address: _____	
	Phone: _____

### Pre Startup Checklist

Installing contractor must verify the following items.	
1. Is there any visible shipping damage?	<input type="checkbox"/> Yes <input type="checkbox"/> No
2. Is the unit level?	<input type="checkbox"/> Yes <input type="checkbox"/> No
3. Are the unit clearances adequate for service and operation?	<input type="checkbox"/> Yes <input type="checkbox"/> No
4. Do all access doors open freely and are the handles operational?	<input type="checkbox"/> Yes <input type="checkbox"/> No
5. Have all shipping braces been removed?	<input type="checkbox"/> Yes <input type="checkbox"/> No
6. Have all electrical connections been tested for tightness?	<input type="checkbox"/> Yes <input type="checkbox"/> No
7. Does the electrical service correspond to the unit nameplate?	<input type="checkbox"/> Yes <input type="checkbox"/> No
8. On 208/230V units, has transformer tap been checked?	<input type="checkbox"/> Yes <input type="checkbox"/> No
9. Has overcurrent protection been installed to match the unit nameplate requirement?	<input type="checkbox"/> Yes <input type="checkbox"/> No
10. Have all set screws on the fans been tightened?	<input type="checkbox"/> Yes <input type="checkbox"/> No
11. Do all fans rotate freely?	<input type="checkbox"/> Yes <input type="checkbox"/> No
12. Does the field water piping to the unit appear to be correct per design parameters?	<input type="checkbox"/> Yes <input type="checkbox"/> No
13. Is all copper tubing isolated so that it does not rub?	<input type="checkbox"/> Yes <input type="checkbox"/> No
14. Are air filters installed with proper orientation?	<input type="checkbox"/> Yes <input type="checkbox"/> No
15. Have condensate drain and p-trap been connected?	<input type="checkbox"/> Yes <input type="checkbox"/> No
16. Are ventilation and exhaust openings unobstructed?	<input type="checkbox"/> Yes <input type="checkbox"/> No
17. Are markings, decals, and warnings on unit clearly visible?	<input type="checkbox"/> Yes <input type="checkbox"/> No
18. Are all damaged or illegible markings and warnings replaced?	<input type="checkbox"/> Yes <input type="checkbox"/> No

**Ambient Temperature**

Ambient Dry Bulb Temperature _____ °C/°F	Ambient Wet Bulb Temperature _____ °C/°F
--	--

**Voltage**

L1-L2	L2-L3	L1-L3
L1-Ground	L2-Ground	L3-Ground

**Supply Fan Assembly**

Alignment <input type="checkbox"/>		Check Rotation <input type="checkbox"/>		Nameplate Amps _____	
Number	hp	L1 Volts/Amps	L2 Volts/Amps	L3 Volts/Amps	
1					
2					
VAV Controls _____					

**Compressors/DX Cooling**

Check Rotation <input type="checkbox"/>					
Number	L1 Volts/Amps	L2 Volts/Amps	L3 Volts/Amps	Head Pressure PSIG	Suction Pressure PSIG
1					

**Refrigeration System 1 - Cooling Mode**

	Pressure	Saturated Temperature	Line Temperature	Sub-cooling	Superheat
Discharge				N/A	N/A
Suction				N/A	
Liquid					N/A

**Refrigeration System 1 - Heating Mode (Heat Pump Only)**

	Pressure	Saturated Temperature	Line Temperature	Sub-cooling	Superheat
Discharge				N/A	N/A
Suction				N/A	
Liquid					N/A

**Unit Configuration**

Water-Cooled Condenser <input type="checkbox"/>	
No Water Leaks <input type="checkbox"/>	Condenser Safety Check <input type="checkbox"/>

Water Flow _____ gpm	
Water Inlet Temperature _____ °C/°F	Water Outlet Temperature _____ °C/°F

**Water/Glycol System**

1. Has the entire system been flushed and pressure checked?	<input type="checkbox"/> Yes <input type="checkbox"/> No
2. Has the entire system been filled with fluid?	<input type="checkbox"/> Yes <input type="checkbox"/> No
3. Has air been bled from the heat exchangers and piping?	<input type="checkbox"/> Yes <input type="checkbox"/> No
4. Is the glycol the proper type and concentration (N/A if water)?	<input type="checkbox"/> Yes <input type="checkbox"/> No
5. Is there a minimum load of 50% of the design load?	<input type="checkbox"/> Yes <input type="checkbox"/> No
6. Has the water piping been insulated?	<input type="checkbox"/> Yes <input type="checkbox"/> No
7. What is the freeze point of the glycol (N/A if water)? _____	

**Mixing Box Dampers**

Operation Check <input type="checkbox"/>	Damper Wiring Check <input type="checkbox"/>	Gears Check <input type="checkbox"/>
Damper Actuator Type: _____		
Economizer Changeover Type and Operations: _____		

**Electric Heating**

Stages _____		Limit Lockout <input type="checkbox"/>		Aux. Limit Lockout <input type="checkbox"/>	
Stage	Amps	Stage	Amps	Stage	Amps
1		5			
2		6			
3		7			
4		8			



### Maintenance Log

This log must be kept with the unit. It is the responsibility of the owner and/or maintenance/service contractor to document any service, repair or adjustments. AAON Service and Warranty Departments are available to advise and provide phone help for proper operation and replacement parts. The responsibility for proper startup, maintenance, and servicing of the equipment falls to the owner and qualified licensed technician.

Entry Date	Action Taken	Name/Tel.

# Maintenance Log (E-Coated Coil)

## AAON E-COATED COIL MAINTENANCE RECORD

Installation Site \_\_\_\_\_ Installation Date \_\_\_\_\_  
 Unit Model # \_\_\_\_\_ Unit Location \_\_\_\_\_  
 Unit Serial # \_\_\_\_\_ Customer \_\_\_\_\_

Year 20__	Ambient Temp (°F)	Surface Debris Removed	Coil Cleaned	Approved Cleaner Used	Potable Water Backwash Rinse	Potable Water Frontwash Rinse	Chlorides Removed	Comments
Jan								
Feb								
Mar								
Apr								
May								
Jun								
Jul								
Aug								
Sep								
Oct								
Nov								
Dec								

The following cleaning agents have been approved for use on AAON E-Coated Coils to remove mold, mildew, dust, soot, greasy residue, lint and similar particulate without harming the coated surfaces.

CLEANING AGENT	RESELLER	PART NUMBER	RECOMMENDED CHLORIDE REMOVER
GulfClean™ Coil Cleaner or Enviro-Coil Cleaner	Rectorseal 2601 Spenwick Drive, Houston, Texas 77055 (P): 713-263-8001	G074480 / 80406 or V82540	Rectorseal 2601 Spenwick Drive, Houston, Texas 77055 (P): 713-263-8001
GulfClean Salt Reducer™	" "	G074490 / 80408	

**October 2022**

Added E=No Paint option to Feature 17, while removing 0=No Paint option so the SA Series and SB Series will have consistent feature options. Leaving 0 = No Paint in this document for older units. Added E = 1 Blower + Perm Magnet AC TEFC Motor + VFD option to Feature 5A.

**November 2023**

Start of new UL 60335 version of SB series IOM Rev. A. Added New UL 60335 tables and standard. Added 35 and 65 KAIC tables. Add Min and Max Water temps and pressures table. Added 454B Pressure Temperature charts as well as metric and imperial versions of 410A and 454B. Add new warning labels. Updated Feature string. Added metric conversions to all units in the IOM.

**March 2024**

Additional warnings added. Text added to installation section about proper ventilation requirements. Minimum Floor Area for charge table added. Additional checklist items added to Startup form. Sentence added to storage section in regards to ASHRAE 15 requirements. Added section about proper Refrigerant removal and Evacuation.

**May 2024**

Removed information pertaining to 454b since this manual should be used ONLY for 410a refrigerant.



**AAON**  
**203 Gum Springs Rd.**  
**Longview, TX 75602-1721**  
**www.AAON.com**

**SB Series**  
**Installation, Operation &**  
**Maintenance**  
**G149170 · Rev. A · 240502**  
**(LV J000301)**

**Factory Technical Support: 918-382-6450**

**Note:** Before calling Technical Support, please have the model and serial number of the unit available.

**Parts:** For replacement parts please contact your local AAON Representative.

It is the intent of AAON to provide accurate and current product information. However, in the interest of product improvement, AAON reserves the right to change pricing, specifications, and/or design of its product without notice, obligation, or liability.