



VCCX-454-GH Controller

Technical Guide

ASM07792
Software SS1207

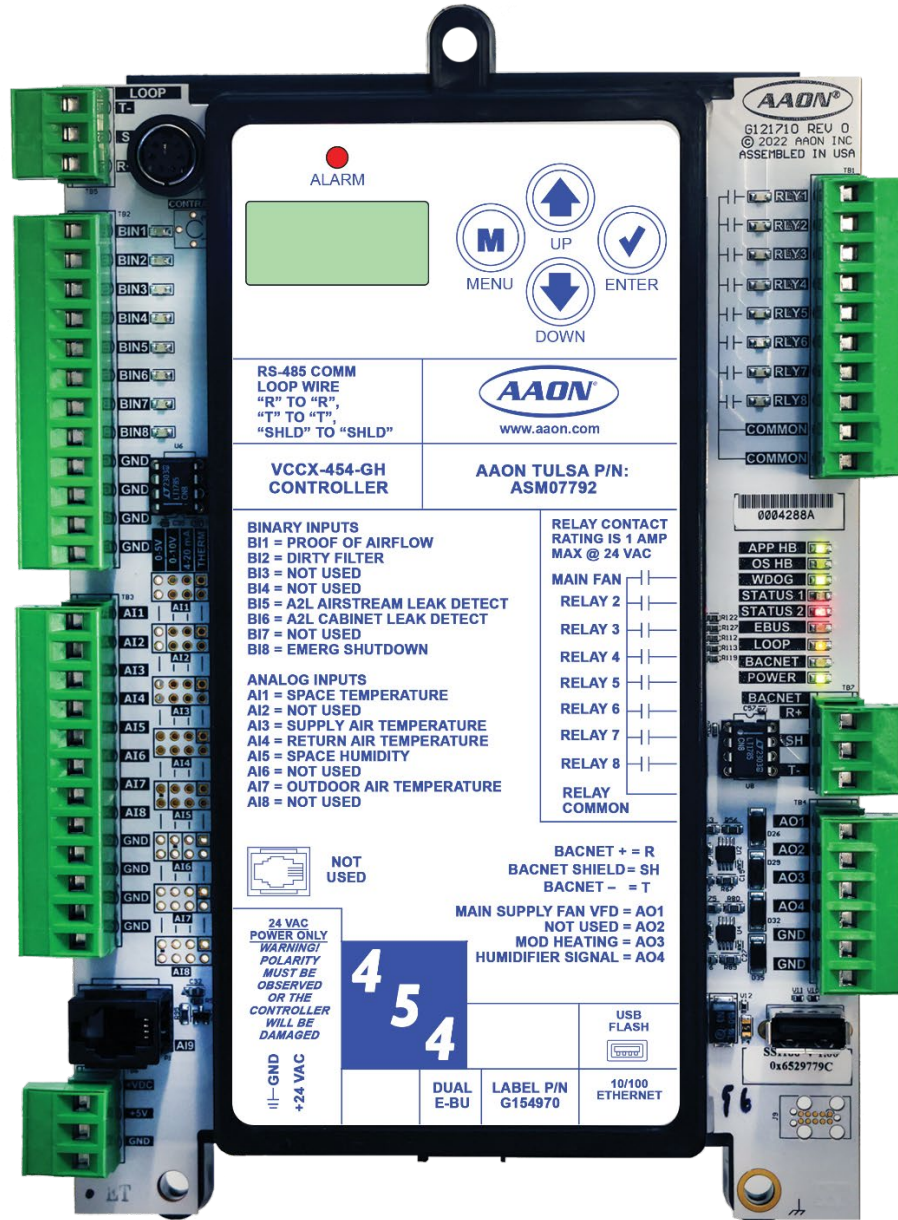



TABLE OF CONTENTS

1. NOTES, CAUTIONS, AND WARNINGS	7
2. OVERVIEW.....	8
2.1. Features	8
2.2. Parts Number Cross Reference.....	10
2.3. Parts and Descriptions	11
2.4. VCCX-454-GH Controller Components.....	19
3. DIMENSIONS	20
3.1. VCCX-454-GH Controller	20
3.2. RSMD-GH Module.....	21
3.3. 12 Relay E-BUS Module.....	22
3.4. A2L Mitigation Controller	23
4. WIRING	24
4.1. Important Wiring Considerations.....	24
5. SAFETY	26
5.1. A2L Leak Detection Sequences.....	26
6. WIRING	28
6.1. VCCX-454-GH	28
6.2. Sensors	30
6.3. Devices	37
6.4. Modules	40
7. START-UP AND COMMISSIONING.....	45
7.1. Start-up and Commissioning	45
8. INPUTS AND OUTPUTS	46
8.1. VCCX-454-GH Controller	46
9. SEQUENCE OF OPERATIONS.....	50
9.1. Mode of Operation	50
9.2. Heating Operation	54
9.3. Space Sensor Options.....	55
9.4. Alarms	56
9.5. Trend Logs	59
10. TROUBLESHOOTING.....	65
10.1. VCCX-454-GH Controller and RSM LED Diagnostics	65
10.2. VCCX-454 Controller LED Diagnostics	67
10.3. Temperature Sensor Testing.....	68



- 11. APPENDIX A - SYSTEM CONFIGURATION 69
 - 11.1. System Configurations..... 69
- 12. APPENDIX B - VCCX-454-GH LCD SCREENS 70
 - 12.1. Navigation Keys..... 70
 - 12.2. Main Screens Map..... 71
 - 12.3. Setting Screens 72
 - 12.4. Status Screens..... 73
 - 12.5. Alarm Screens..... 74
 - 12.6. Output Override Screens..... 76
 - 12.7. Air Balance Screens..... 77
- 13. APPENDIX C - VCCX-454-GH BACNET..... 78
 - 13.1. VCCX-454-GH BACnet Connection to MS/TP Network..... 78
 - 13.2. BACnet Connection to MS/TP or IP Network..... 79
 - 13.3. VCCX-454-GH BACnet Analog Parameters 80
 - 13.4. VCCX-454-GH BACnet PICS 87
- 14. REVISION HISTORY 88

TABLE OF FIGURES

Figure 1: VCCX-454-GH Controller Components.....	19
Figure 2: VCCX-454-GH Controller Dimensions	20
Figure 3: RSMD-GH Controller Dimensions.....	21
Figure 4: 12 Relay E-Bus Module Dimensions.....	22
Figure 5: A2L Mitigation Controller Dimensions	23
Figure 6: VCCX-454-GH Controller Inputs Wiring.....	28
Figure 7: VCCX-454-GH Controller Outputs Wiring	29
Figure 8: E-BUS Digital Room Sensor Wiring.....	30
Figure 9: Space Temperature Sensor Wiring	31
Figure 10: Supply Air Temperature Sensor Wiring.....	32
Figure 11: Return Air Temperature Sensor Wiring.....	33
Figure 12: Analog Humidity Sensor Wiring	34
Figure 13: Outdoor Air Temperature Sensor Wiring.....	35
Figure 14: E-Bus Temperature and Humidity Sensor Wiring	36
Figure 15: Supply Fan VFD Wiring.....	37
Figure 16: Modulating Heating Device Wiring.....	38
Figure 17: Humidifier Wiring	39
Figure 18: 12 Relay E-BUS Expansion Module Wiring	40
Figure 19: RSMD-GH Inputs Wiring	41
Figure 20: RSMD-GH Outputs Wiring.....	42
Figure 21: MHGRV-X Series Module to VCCX-454-GH Controller Wiring (MHGRV-X shown).....	43
Figure 22: MODGAS-XWR2 Series Module to VCCX-454-GH Controller Wiring (MODGAS-XWR2 shown)	44
Figure 23: Prism 2 Details Viewer Button	59
Figure 24: Standard Log Dropdown Button	59
Figure 25: Load Log Option in the Trend Logs Screen	59
Figure 26: Location of Loading Log Data Ticket Number	59
Figure 27: Export Daily Button Generates Report.....	59
Figure 28: Saving the Report to the Computer	59
Figure 29: Opening the File.....	59
Figure 30: VCCX-454-GH Controller LED Locations	67
Figure 31: LCD Display and Navigation Keys	70
Figure 32: VCCX-454-GH Main Screens Map	71
Figure 33: VCCX-454-GH Setting Screens.....	72
Figure 34: VCCX-454-GH Status Screens.....	73
Figure 35: VCCX-454-GH Alarm Screens.....	74



Figure 36: VCCX-454-GH Output Override Screens 76

Figure 37: VCCX-454-GH Air Balance Screens 77

Figure 38: VCCX-454-GH BACnet Connection to MS/TP Network..... 78

Figure 39: Wiring Example - Shield (Drain) Wiring for Isolated and Non-Isolated Connections..... 79



TABLE OF TABLES

Table 1: Parts Number Cross Reference.....	10
Table 2: Parts, Descriptions, and Illustrations	11
Table 3: Voltage and Environment Requirements	24
Table 4: VCCX-454-GH Controller Inputs and Outputs	46
Table 5: User-Configurable Relay Outputs.....	49
Table 6: VCCX-454-GH Trend Log Status Points.....	61
Table 7: VCCX-454-GH Trend Log Enumerated Values.....	61
Table 8: VCCX-454-GH Trend Log Bit Strings	62
Table 9: RSMD-GH Module Trend Logs	63
Table 10: RSMD-GH Trend Log Bit Strings.....	64
Table 11: 0-5V Temperature Sensor – Voltage and Resistor Type for Type III 10 K OHM Thermistor Sensors	68
Table 12: Navigation Key Functions.....	70
Table 13: Editing Key Functions	70
Table 14: Alarm Screens	75
Table 15: VCCX-454-GH Analog Inputs	80
Table 16: VCCX-454-Analog Values.....	82
Table 17: VCCX-454-GH Binary Inputs.....	83
Table 18: VCCX-454-GH Multi-State Inputs.....	86
Table 19: VCCX-454-GH Multi-State Values	86
Table 20: VCCX-454-GH BACnet Protocol Implementation Conformance Statement	87

1. NOTES, CAUTIONS, AND WARNINGS

NOTE: Notes are intended to clarify the unit installation, operation, and maintenance.

 **CAUTION**

Caution statements are given to prevent actions that may result in equipment damage, property damage, or personal injury.

 **WARNING**

Warning statements are given to prevent actions that could result in equipment damage, property damage, or serious personal injury.

 **DANGER**

Danger statements are given to prevent actions that will result in equipment destruction, property damage, and severe personal injury or death.

2. OVERVIEW

The AAON VCCX-454-GH Controller can provide the precise temperature and humidity control needed to optimize plant development. The controller allows growers to set the Modes of Operation, space humidity, and temperature setpoints at different phases of the plant growth.

AAON uses modulating reheat and electronic valves to maintain the conditions the grower desires. VCCX-454-GH Controller comes with standard programming that keeps the compressor in its safe operating envelope for reliable operation.

Some indoor agriculture facility operating conditions, necessary for ideal plant growth, put the compressor outside its safe operating envelope. The VCCX-454-GH Controller is designed specifically for these conditions.

While providing comfort conditions for humans allows a wide range of applications dependent on building conditions and desired end result, optimizing an indoor farm for plant development requires strict control, decreasing the possible application options.

2.1. Features

The VCCX-454-GH Controller is designed with eight analog inputs, four analog outputs, eight binary inputs, and eight relay outputs (seven configurable). It also has an on-board BACnet port for connection to an MS/TP network. The controller contains a 2 x 8 LCD character display and four buttons that allow for configuration and status of settings, alarms, force modes, and BACnet configuration.

The VCCX-454-GH Controller can communicate with the RSMD-GH. In addition, the MHGRV-X series modules, MODGAS-XWR2 series modules, and 12 Relay E-BUS Expansion Module provide additional inputs and outputs. There are also two E-BUS expansion ports, which allow the use of communicating sensors and E-BUS modules.

Other features of the VCCX-454-GH include:

- A2L Mitigation Controller
- Controls digital compressors
- Controls up to 12 stages of heat
- Modulating heating output (SCR Electric Heat Control)
- Full integration with the AAON Refrigerant System Module for Digital Compressors for indoor agriculture (RSDM-GH)
- Full integration with the MODGAS-XWR2 series modules
- Full integration with the MHGRV-X series modules
- Advanced dehumidification capabilities
- Primary/secondary heating control
- Fan proving interlock
- Dirty Filter Alarm
- Emergency Shutdown Input (Smoke Detector/Firestat or other shutdown conditions)
- Daylight Savings Time adjustment
- Trend logging capability
- Head pressure control
- On-board BACnet port for connection to an MS/TP network, see Figure 38.

NOTE: Set-up, configuring, and monitoring of the VCCX-454-GH Controller requires Prism 2 front-end software used with a personal computer.



BACnet is a registered trademark of ASHRAE. ASHRAE does not endorse, approve or test products for compliance with ASHRAE

standards. Compliance of listed products to the requirements of ASHRAE Standard 135 is the responsibility of BACnet International. BTL is a registered trademark of BACnet International.

2.2. Parts Number Cross Reference

Table 1: Parts Number Cross Reference

Part Description	AAON
VCCX-454-GH Controller	ASM07792
A2L Mitigation Controller	ASM07563
Refrigerant System Module for Digital Compressors - Grow House (RSMD-GH)	ASM06717
MODGAS-XWR2 Module	ASM01695
MODGAS-XWR2-B Module	ASM06909
MHGRV-X Module	ASM01670
MHGRVX-A1 Module	ASM07265
MHGRVX-A2 Module	ASM06926
MHGRVX-B1 Module	ASM06910
MHGRVX-B2 Module	ASM06927
MHGRV Reheat Expansion Module	ASM01687
12 Relay E-BUS Expansion Module	ASM01873
LA Auxiliary Board	ASM06718
Standard Room Sensor - Plain	ASM02227
E-BUS Digital Room Sensor - LCD - Temp and RH	ASM01820
E-BUS Digital Room Sensor - No LCD - Temp and RH	ASM02221
E-BUS Horizontal Outdoor Air Temperature and RH Sensor	ASM01836
E-BUS Vertical Outdoor Air Temperature and RH Sensor	ASM01838
E-BUS Return Air Temperature and RH Sensor	ASM01840
E-BUS Cable Assembly E-BUS Power and Comm 1.5 ft., 3 ft., 10 ft., 25 ft., 50 ft., 75 ft., 100 ft., 150 ft., 250 ft., and 1000 ft. Spool	G029440 (1.5 ft.), G012870 (3 ft.), G029460 (10 ft.), G045270 (25 ft.), G029510 (50 ft.), G029530 (75 ft.), G029450 (100 ft.), G029470 (150 ft.), V36590 (250 ft.), G018870 (1000 ft. Spool)
E-BUS Bulk Connectors	G018890
E-BUS Crimp Tool	G034180
Outdoor Air Temperature Sensor	G042230
Space Humidity Sensor	ASM01646
Duct Temperature Sensor (6 in. or 12 in.)	G051240 (6 in.), G051250 (12 in.)
CommLink 6 Communications Interface	ASM01874
IP Module Kit for CommLink 6	ASM01902
USB-Link 2 Kit	ASM02244
MiniLink Polling Device 5	ASM01626
FieldServer BACnet Router	G107780
Prism 2 Front-End Computer Software	ASM02533
E-BUS Adapter Board	ASM01878
E-BUS Adapter Hub	G033970
E-BUS Adapter Hub with 1.5 ft. EBC Cable	ASM01635
E-BUS Space Temp/RH Sensor Emulator Board	ASM01696
E-BUS Return Air Temp/RH Sensor Emulator Board	ASM01621
E-BUS Outdoor Air Temp/RH Sensor Emulator Board	ASM01697
Communication Surge Protector Kit	ASM01907

2.3. Parts and Descriptions

Table 2: Parts, Descriptions, and Illustrations

VCCX2 Parts and Descriptions		
Part No.	Part Description	Illustration
ASM07792	<p>VCCX-454-GH Controller</p> <p>The VCCX-454-GH Controller provides eight analog inputs, four analog outputs, eight binary inputs, and eight relay outputs. It also has an on-board BACnet port for connection to an MS/TP network. The controller contains a 2 x 8 LCD character display and four buttons that allow for status and alarm display as well as BACnet configuration. It allows for the addition of the RSM, EM1 Expansion Module, and the 12 Relay E-BUS Expansion Module.</p> <p>NOTE: Set-up, configuring, and monitoring of the VCCX-454-GH Controller requires Prism 2 front-end software used with a personal computer.</p>	
ASM07563	<p>A2L Mitigation Controller</p> <p>The A2L Mitigation Controller is part of the Refrigerant Detection system and is designed to detect A2L refrigerant leaks in the airstream and/or cabinet. The A2L Mitigation Controller has three sensor inputs, one binary input, and four relays.</p>	
ASM06717	<p>RSMD-GH Module</p> <p>The Refrigerant System Module for Digital Compressors (RSMD-GH) monitors and controls one or two refrigeration circuits of the HVAC unit. The module is designed for R410-A refrigerant. Up to four RSMD-GH Modules can be connected, depending on the size of the system. There are two E-BUS expansion ports, which allow for the use of communicating sensors and E-BUS modules. The RSMD-GH provides three analog inputs, four binary inputs, five relays, and two analog outputs. It connects with an E-BUS cable to the VCCX-454-GH Controller.</p>	

VCCX2 Parts and Descriptions		
Part No.	Part Description	Illustration
ASM01695 ASM06909	MODGAS-XWR2 Module MODGAS-XWR2-B Module The MODGAS-XWR2 series modules are designed to be used with White-Rodgers valves only. It will modulate up to two White-Rodgers gas valves to maintain a desired discharge (supply) air temperature. Up to four modulating gas valves may be controlled when a second MODGAS-XWR2 is configured as a slave module. It also controls the speed of the induced draft fan to maintain proper combustion in the heat exchanger. It connects with an E-BUS cable to the VCCX-454-GH Controller.	
ASM01670 ASM07265 ASM06926 ASM06910 ASM06927	MHGRV-X Module MHGRVX-A1 Module MHGRVX-A2 Module MHGRVX-B1 Module MHGRVX-B2 Module The MHGRV-X series modules control a modulating hot gas reheat valve to maintain a desired supply air temperature and Dehumidification Setpoint. It connects with an E-BUS cable to the VCCX-454-GH Controller.	
ASM01687	MHGRV REHEAT Expansion Module The MHGRV Reheat Expansion Module is designed to control one set of reheat valves. The Reheat Expansion Module connects to the MHGRV-X via an E-BUS communication cable. Connected together, the Reheat Expansion Modules provide a system that allows the proper control of multiple sets of valves.	
ASM01873	12 Relay E-BUS Expansion Module The 12 Relay Expansion Module adds 12 configurable relays to the VCCX-454-GH Control System. It connects to the VCCX-454-GH Controller with an E-BUS cable.	

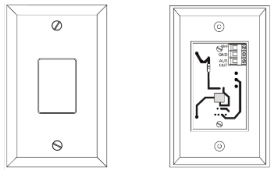
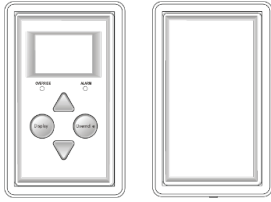
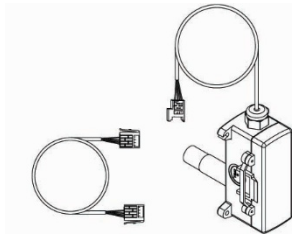
VCCX2 Parts and Descriptions		
Part No.	Part Description	Illustration
ASM06718	<p>LA Auxiliary Board</p> <p>For LAC valve control. The LA Auxiliary Board is used on low ambient applications to control a bypass valve to control the liquid pressure to a liquid pressure setpoint. It connects with an E-BUS cable to the VCCX-454-GH controller.</p>	
ASM02227	<p>Standard Room Sensor</p> <p>Includes: Standard Room Sensor. For wall mounting. Use with VCCX-454-GH Controller only. Connects to the controller via field fabricated wiring.</p>	
ASM01820 ASM02221	<p>E-BUS Digital Room Sensor - Temp Only and Temp and Humidity</p> <p>The ASM01820 and ASM02221 (no LCD display) are used with the VCCX-454-GH Controller for room air temperature and humidity sensing applications. Both use E-BUS cables.</p>	
ASM01836	<p>E-BUS Horizontal Outdoor Air Temperature and Humidity Sensor</p> <p>Used for outdoor air temperature and humidity sensing applications. Connects to VCCX-454-GH Controller or E-BUS Adapter Hub using E-BUS cable.</p> <p>Includes: E-BUS Horizontal Outdoor Air Temperature and Humidity Sensor, mounted in a weatherproof handy box with attached 3 ft. E-BUS cable with jack. A 25 ft. E-BUS cable is included to connect to the VCCX-454-GH Controller. If a longer E-BUS cable is required, it must be ordered separately.</p>	

VCCX2 Parts and Descriptions		
Part No.	Part Description	Illustration
ASM01838	<p>E-BUS Vertical Outdoor Air Temperature and Humidity Sensor</p> <p>Used for outdoor air temperature and humidity sensing applications. Connects to VCCX-454-GH Controller or E-BUS Adapter Hub using E-BUS cable.</p> <p>Includes: E-BUS Vertical Outdoor Air Temperature and Humidity Sensor, mounted in a weatherproof handy box with attached 3 ft. E-BUS cable with jack. A 25 ft. E-BUS cable is included to connect to the VCCX-454-GH Controller. If a longer E-BUS cable is required, it must be ordered separately.</p>	
ASM01840	<p>E-BUS Return Air Temperature and Humidity Sensor</p> <p>Used for return air temperature and humidity sensing applications.</p> <p>Connects to VCCX-454-GH Controller or E-BUS Adapter Hub using E-BUS cable.</p> <p>Includes: E-BUS Return Air Temperature and Humidity Sensor, mounted in a weatherproof handy box attached with a 3 ft. E-BUS cable with jack. A 50 ft. E-BUS cable is included to connect to the VCCX-454-GH Controller. If a longer E-BUS cable is required, it must be ordered separately.</p>	
<p>G029440 (1.5F) G012870 (3F) G029460 (10F) G045270 (25F) G029510 (50F) G029530 (75F) G029450 (100F) G029470 (150F) V36590 (250F) G018870 (SPOOL)</p>	<p>E-BUS Cables</p> <p>The E-BUS cables connect to the VCCX-454-GH Controller, VCC-X Expansion Modules, and E-BUS Sensors. Different lengths can be joined together using an E-BUS Adapter Hub, if necessary. The E-BUS cables are available in 1.5 ft., 3 ft., 10 ft., 25 ft., 50 ft., 75 ft., 100 ft., 150 ft., and 250 ft. lengths.</p> <p>Includes: E-BUS Cable Assembly. The E-BUS CABLE SPOOL is a bulk E-BUS cable that can be used with the E-BUS Bulk Connectors.</p>	

VCCX2 Parts and Descriptions		
Part No.	Part Description	Illustration
G018890	<p>E-BUS Bulk Connectors</p> <p>Attaches to E-BUS Spool Cable. Must be crimped using either the G034180 E-BUS Crimp Tool or one matching the requirements listed in the pricing list.</p> <p>Includes: E-BUS Bulk Connector.</p>	
G034180	<p>E-BUS Crimp Tool</p> <p>Crimps the E-BUS Connectors for use with the E-BUS Spool Cable. Includes: E-BUS Crimp Tool.</p>	
G042230	<p>Outdoor Air Temperature Sensor</p> <p>Used for temperature sensing applications.</p> <p>Includes: 10K ohm Outdoor Air Temperature Sensor, two wire, mounted in a weatherproof handy box only.</p>	
G051240 (6") G051250 (12")	<p>Duct Temperature Sensor - 6" Probe Duct Temperature Sensor - 12" Probe</p> <p>G051240 = 6" probe length. G051250 = 12" probe length. Used for return or supply air temperature sensing applications.</p> <p>Includes: 10K ohm Duct Temperature Sensor, two-wire only.</p>	

VCCX2 Parts and Descriptions		
Part No.	Part Description	Illustration
<p>ASM01874</p>	<p>CommLink 6 Communications Interface</p> <p>The CommLink 6 connects to the control system using a USB computer connection to provide direct on-site communications with the control system from a computer with the Prism 2 software installed. For remote communications, see the IP Module Kit.</p> <p>Includes: CommLink 6, 6 ft. USB cable, and 120/24 VAC power supply. Required on all networked systems or if a direct computer or remote computer connection is required. Connects to the user's computer USB 1.1 or 2.1 port. Prism 2 computer front-end software must be installed directly connected or remotely connected to a computer to communicate with the user's system.</p>	
<p>ASM01902</p>	<p>IP Module Kit - Internet/LAN Connection</p> <p>Used for Internet or Local Area Network communications with the control system. Field installs by plugging into the CommLink 6 circuit board and provides an addressable Ethernet connection to the controls system from any computer connected to the building's LAN. It can also be configured to allow access to the control system from the Internet through the LAN if the Ethernet firewall is configured for this option.</p> <p>Includes: IP Link module, 10 ft. long Ethernet cable, and installation instructions. Prism 2 computer front-end software must be installed on the remote computer in order to dial-up and communicate with the controls system.</p>	

VCCX2 Parts and Descriptions		
Part No.	Part Description	Illustration
ASM02244	<p>USB-Link 2 Kit</p> <p>The USB-Link 2 is a pocket-sized communications interface used to connect a laptop computer to the control system for programming and monitoring, using a modular cable to connect to the service port connector on the controllers and a USB cable to connect to a laptop computer.</p> <p>Includes: USB-Link 2 for multiple or single loop systems, USB cable, modular connection cable, two mini-DIN to terminal adapters, and Prism 2 software.</p>	
ASM01626	<p>MiniLink PD 5</p> <p>Used with all Orion controllers to provide network communications, zone voting, alarming, and tenant logging capabilities. A MiniLink Polling Device is required on each loop of a networked system.</p> <p>Includes: MiniLink Polling Device 5.</p>	
G107780	<p>FieldServer BACnet Router</p> <p>Connects up to two AAON VCCX-454-GH Controllers to a BACnet IP network. The router has three physical communications ports – one 10/100 Mbps Ethernet port and two RS-485 MS/TP ports – and can connect two VCCX-454-GH controlled units to an Ethernet network. It uses standard Ethernet cables for commissioning and installation. DHCP automatically obtains IP settings from the network.</p>	

VCCX2 Parts and Descriptions		
Part No.	Part Description	Illustration
ASM02533	<p>Prism 2 Front-End Computer Software</p> <p>Prism 2 provides standard, easy-to-understand status screens for each type of equipment installed. Prism 2 software has provisions for custom screens, which allow floor plans, equipment photos, or user-defined summary screens to be implemented to meet their own individual needs. All controlling setpoints, trend logs, and alarm conditions are accessed in the Prism environment. Prism can be configured for direct on-site installation, remote modem connection, or TCP/IP Internet connection to several installations.</p>	
ASM01878	<p>E-BUS Adapter Board</p> <p>The E-BUS Adapter Board is used to connect E-BUS devices together and convert to different types of cables, if needed. It connects with an E-BUS cable to the VCCX-454-GH Controller. Cable supplied separately.</p>	
G033970	<p>E-BUS Adapter Hub</p> <p>The E-BUS Adapter Hub is used for connecting E-BUS devices and controllers together with E-BUS cables of varying lengths.</p> <p>Includes: E-BUS Adapter Hub.</p>	
ASM01635	<p>E-BUS Adapter Hub with 1.5 ft. E-BUS Cable</p> <p>The E-BUS Adapter Hub is used for connecting E-BUS devices and controllers together with E-BUS cables of varying lengths.</p> <p>Includes: E-BUS Adapter Hub and 1.5 ft. E-BUS cable.</p>	
ASM01696	<p>E-BUS Space Temperature and Humidity Sensor Emulator Board with 1.5 ft. E-BUS Cable</p> <p>The E-BUS Space Temperature and Humidity Sensor Emulator Board allows the use of third-party analog space temperature and humidity sensors to emulate the AAON E-BUS Space Temperature and Humidity Sensor.</p> <p>Includes: E-BUS Sensor Emulator Board and 1.5 ft. E-BUS cable.</p>	

2.4. VCCX-454-GH Controller Components

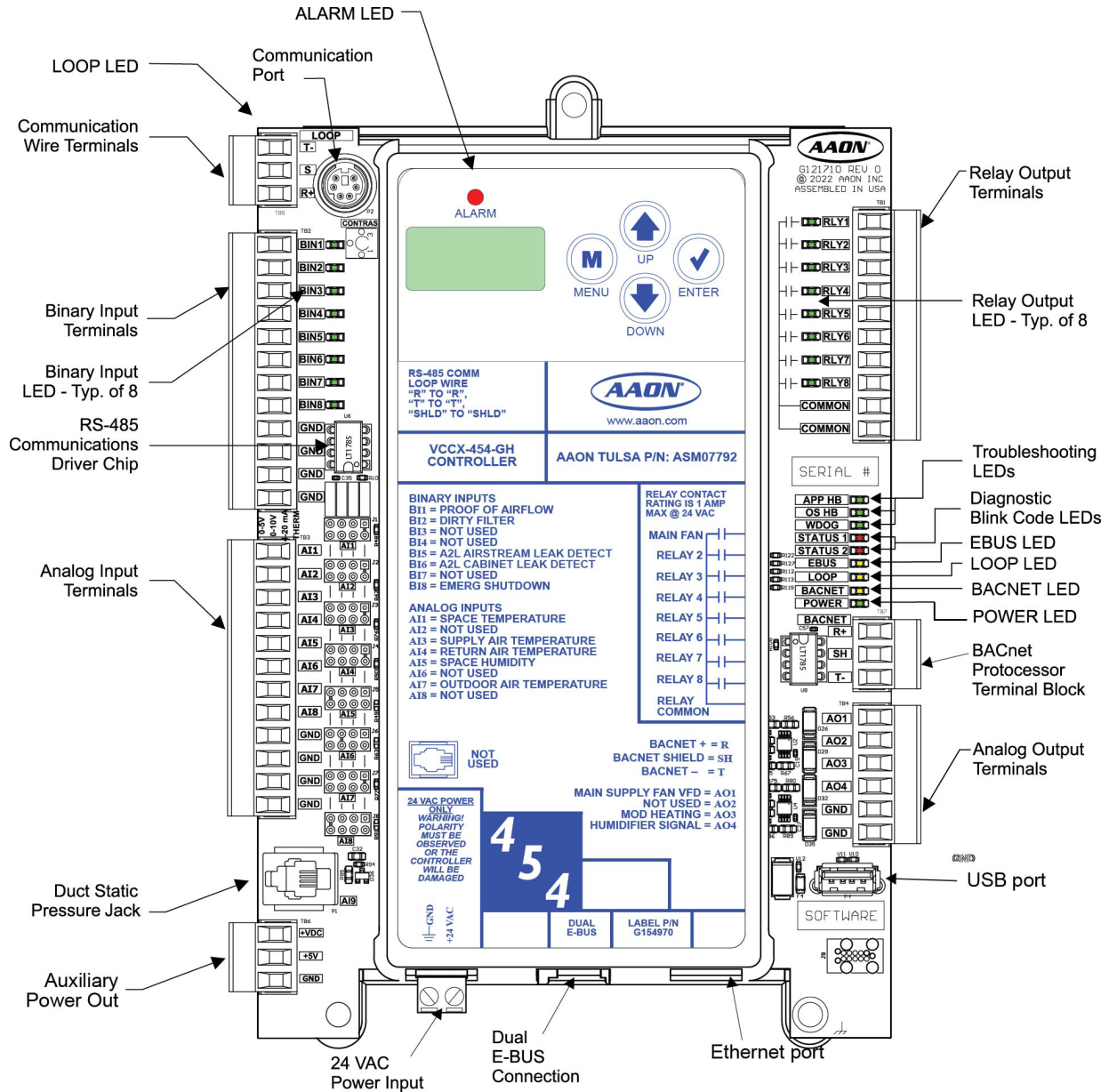

Figure 1: VCCX-454-GH Controller Components

3. DIMENSIONS

3.1. VCCX-454-GH Controller

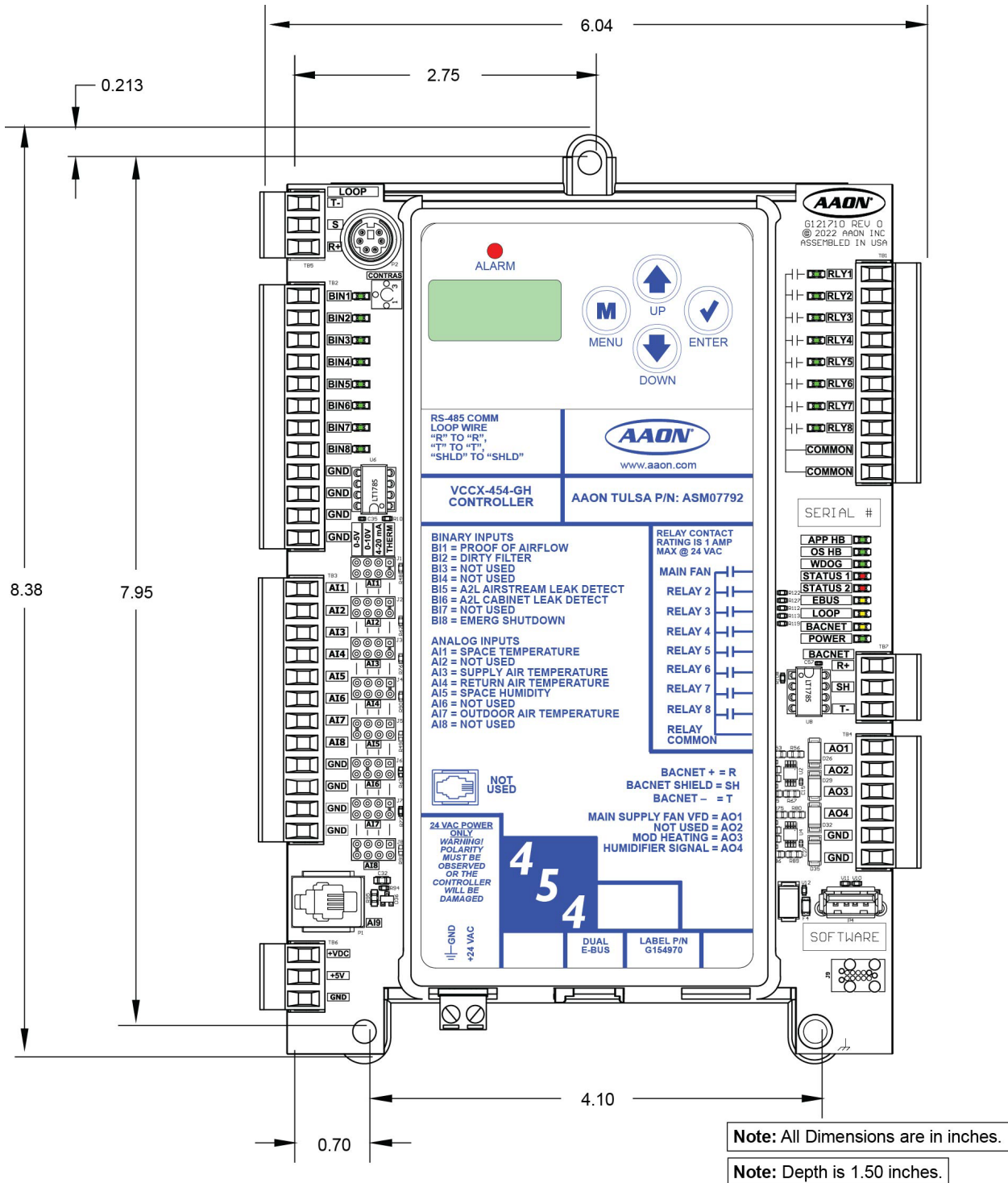

Figure 2: VCCX-454-GH Controller Dimensions

3.2. RSMD-GH Module

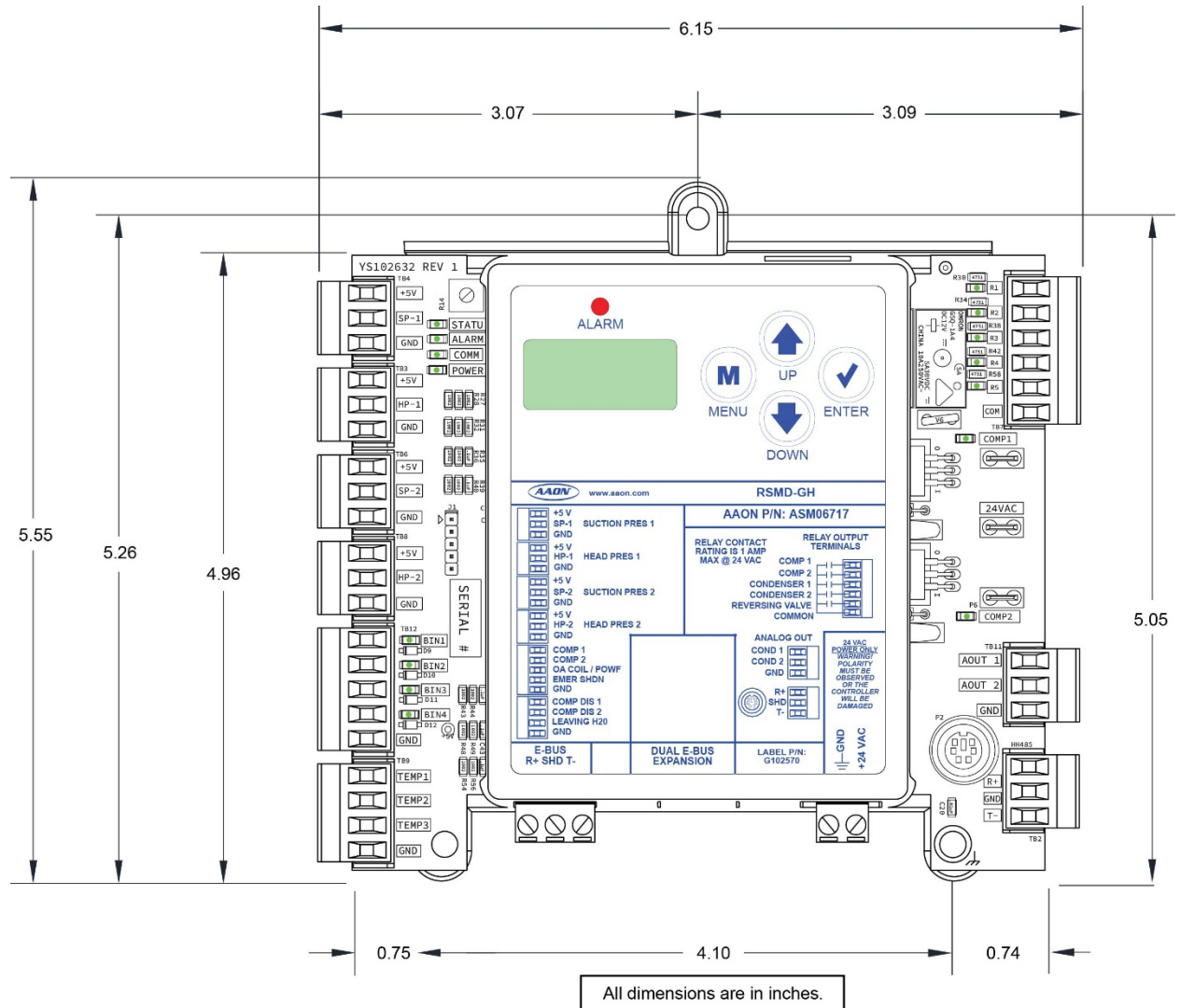
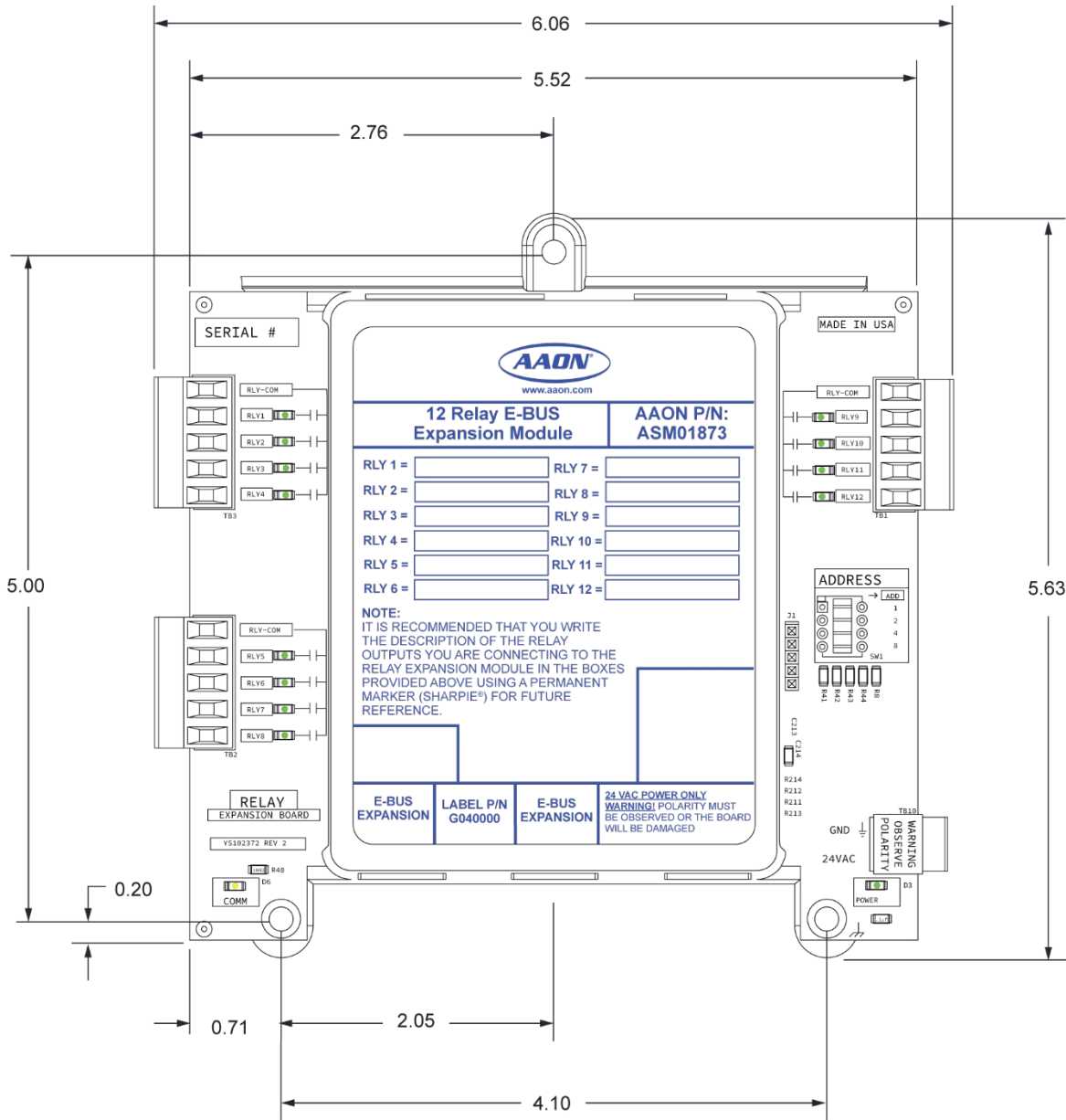

Figure 3: RSMD-GH Controller Dimensions

3.3. 12 Relay E-BUS Module



NOTE: All dimensions are in inches.

NOTE: Depth is 1.50 inches.

Figure 4: 12 Relay E-Bus Module Dimensions

3.4. A2L Mitigation Controller

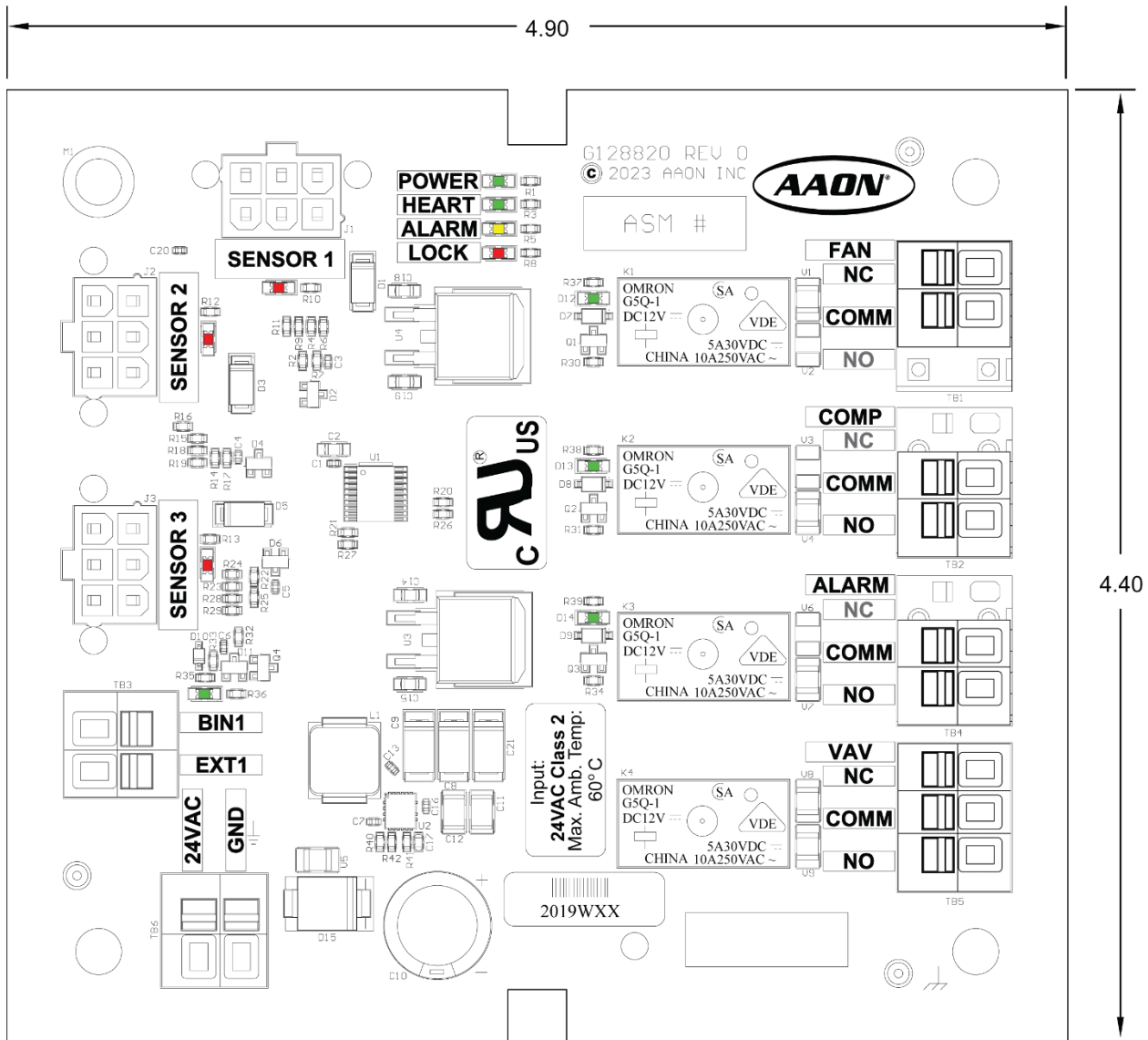

Note: All Dimensions are in inches.

Figure 5: A2L Mitigation Controller Dimensions

4. WIRING

4.1. Important Wiring Considerations

4.1.1. General

Correct wiring of the VCCX-454-GH Controller is the most important factor in the overall success of the controller installation process. In general, most VCCX-454-GH Controllers are installed and wired at the AAON factory. Some of the following information pertains to field wiring and may not apply to the installation if it was pre-wired at the factory. However, if troubleshooting of the controller is required, it is a good idea to be familiar with the system wiring, whether it was factory or field wired.

4.1.2. Controller Mounting

When the controller is to be field mounted, it is important to mount the controller in a location that is free from extreme high or low temperatures, moisture, dust, and dirt. See Table 3, on the right, for a list of the required operating conditions for the VCCX-454-GH Controller and associated expansion modules.

The VCCX-454-GH Controller is housed in a plastic enclosure. It is designed to be mounted by using the three mounting holes in the enclosure base. The VCCX-454-GH Controller needs to be installed in an environment that can maintain a temperature range between -22°F and 158°F not to exceed 95% relative humidity levels (non-condensing). Be careful not to damage the electronic components when mounting the controller.

4.1.3. Wiring

The VCCX-454-GH Controller and expansion modules must be connected to a 24 VAC power source of the proper size for the calculated VA load requirements. All transformer sizing should be based on the VA rating listed in Table 3 below.

Table 3: Voltage and Environment Requirements

Voltage and Environment requirements				
Control Device	Voltage	VA Load	Temperature	Humidity (Non-Condensing)
VCCX-454-GH Controller	18-30 VAC	15	-22°F to 158°F	0-95% RH
RSMD-GH and LA Aux Board	18-30 VAC	18	-22°F to 158°F	0-95% RH
12 Relay E-BUS Expansion Module	18-30 VAC	15	-22°F to 158°F	0-95% RH
MHGRV-X	18-30 VAC	18	-22°F to 158°F	0-95% RH
Reheat Expansion Module	18-30 VAC (25%/-15%) Class 2	12	10°F to 150°F	0-95% RH

WARNING

When using a single transformer to power multiple controllers or expansion modules, the correct polarity must always be maintained between the boards. Failure to observe correct polarity will result in damage to the controller and expansion modules.



Please carefully read and apply the following information when wiring the VCCX-454-GH Controller and modules.

1. All wiring is to be in accordance with local and national electrical codes and specifications.
2. All 24 VAC wiring must be connected so that all ground wires remain common. Failure to follow this procedure can result in damage to the controller and connected devices.
3. Minimum wire size for 24 VAC wiring should be 18-gauge.
4. Minimum wire size for all sensors should be 24-gauge. Some sensors require two-conductor wire, and some require three-or four-conductor wire.
5. Minimum wire size for 24 VAC thermostat wiring should be 22-gauge.
6. Be sure all wiring connections are properly inserted and tightened into the terminal blocks. Do not allow wire strands to stick out and touch adjoining terminals, which could potentially cause a short circuit.
7. When communication wiring is to be used to interconnect VCCX-454-GH Controllers together or to connect to other communication devices, all wiring must be plenum-rated, minimum 18-gauge, two-conductor, twisted pair with shield. AAON can supply communication wire that meets this specification and is color coded for the network or local loop. If desired, Belden #82760 or equivalent wire may also be used.
8. Before applying power to the VCCX-454-GH Controller, be sure to recheck all wiring connections and terminations thoroughly.

4.1.4. Powering Up

When the VCCX-454-GH and connected modules are first powered up, the POWER LED should light up and stay on continuously. If it does not light up, check to be sure the 24 VAC is connected to the controller, the wiring connections are tight, and they are wired for the correct polarity. The 24 VAC power must be connected so all ground wires remain common. If after making all these checks, the POWER LED does not light up, please contact AAON Controls Support for assistance.

5. SAFETY

5.1. A2L Leak Detection Sequences

NOTE: The following sequences are only applicable with a VCCX-454-GH connected to an A2L Mitigation Controller. Refer to the A2L Mitigation Controller Technical Guide for stand-alone sequences.

NOTE: The A2L Leak Detect alarms will stay active on the VCCX-454-GH even if the condition is cleared. Once the leak detection clears, the VCCX-454-GH will operate its regular sequence with the alarms active. The alarms can only be manually cleared by power cycling the VCCX-454-GH or by using the keypad and display on the VCCX-454.

5.1.1. Airstream Leak Detection Only

When the A2L Mitigation Board detects a leak in the airstream, all compressor operations cease immediately, and the A2L Airstream Leak Detect alarm will be activated.

If the unit is commanded to be occupied

- It will operate as it would normally with the compressors locked out. If the supply fan is configured for variable speed, it will ramp up to 100%.

If the unit is commanded unoccupied at any time while the alarm is active

- The unit fan will be forced to operate based on the current control method configured. If the supply fan is configured for variable speed, it will ramp up to 100% in 90 seconds.
- Heating can operate as required; however, it will only operate to the unoccupied control temperatures.
- If the HVAC Mode is SAT Tempering, Outdoor Air (MUA), or DOAS Unit.
 - Operate the unit as if it were in Occupied Mode using regular setpoints.
- If the HVAC Mode is Supply Air, Return Air, Space Temp, Space Temp with High % OA, Single Zone VAV.
 - Operate the unit as if it were in Unoccupied Mode using setback setpoints.
 - If Night Setbacks are set to 30°F (disabling unoccupied operation), run with Occupied setpoints.

Alarms related to compressors not operating should not be activated, as there are no issues with the compressors.



5.1.2. Cabinet Leak Detection Only

When the A2L Mitigation Board detects a leak in the cabinet, the A2L Cabinet Leak Detect alarm will be activated. All compressor and gas heat operations will cease immediately. Electric, hot water, and steam heat sources will still be able to operate.

If the unit is a MUA and the supply air temperature drops below the Low SAT Cutoff setpoint, it will shut the unit down immediately.

If the unit is off, it will stay off.

5.1.3. Cabinet and Airstream Leak Detection

When the A2L Mitigation Board detects a leak in the cabinet and the airstream, both A2L Cabinet Leak Detect Alarms are activated.

If the unit is commanded to be occupied

- It will operate as it would normally with the compressors and gas heat locked out.

If the unit is commanded unoccupied at any time while the alarm is active

- The unit fan will be forced to operate based on the current control method configured. If the supply fan is configured for variable speed, it will ramp up to 100% in 90 seconds.
- If the HVAC Mode is SAT Tempering, Outdoor Air (MUA), or DOAS Unit.
 - Operate the unit as if it were in Occupied Mode using regular setpoints.
- If the HVAC Mode is Supply Air, Return Air, Space Temp, Space Temp with High % OA, Single Zone VAV.
 - Operate the unit as if it were in Unoccupied Mode using setback setpoints.
 - If Night Setbacks are set to 30°F (disabling unoccupied operation), run with Occupied setpoints.

Alarms related to compressors not operating should not be activated, as there are no issues with the compressors.

6. WIRING

6.1. VCCX-454-GH

The VCCX-454-GH Controller is designed with eight analog inputs, four analog outputs, eight binary inputs, and eight relay outputs.

There are also two E-BUS expansion ports, which allow the use of communicating sensors and E-BUS modules.

See Figure 6 below and Figure 7, page 29, for wiring details.

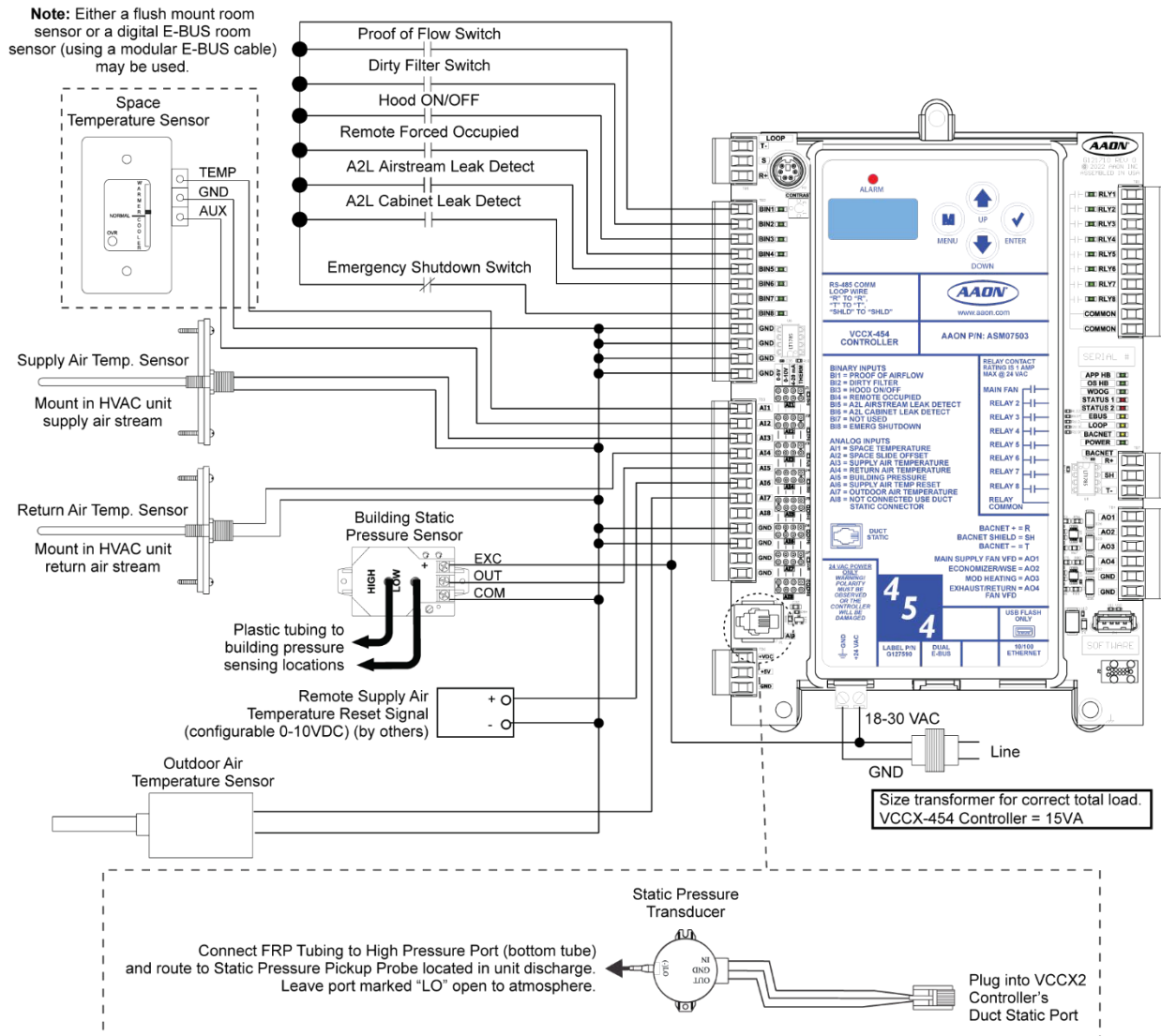

Figure 6: VCCX-454-GH Controller Inputs Wiring

- NOTE:** Relay contacts for R2-R8 may be configured for:
- | | | |
|---------------------|------------------|-------------------------|
| 1.) COOLING STAGES | 9.) PREHEAT | 17.) A1 COMP RUN STATUS |
| 2.) HEATING STAGES | 10.) LOW AMBIENT | 18.) A2 COMP RUN STATUS |
| 3.) AUX HEAT | 11.) EXHAUST | 19.) B1 COMP RUN STATUS |
| 4.) EMERGENCY HEAT | 12.) ECONOMIZER | 20.) B2 COMP RUN STATUS |
| 5.) MOD HEAT ENABLE | 13.) HEAT WHEEL | 21.) CONDENSER PUMP |
| 6.) MOD COOL ENABLE | 14.) OCCUPIED | 22.) SUMP HEATER |
| 7.) MORNING WARM-UP | 15.) OVERRIDE | 23.) SUMP PUMP DRAIN |
| MORNING COOL-DOWN | 16.) ALARM | |
| 8.) REHEAT | | |

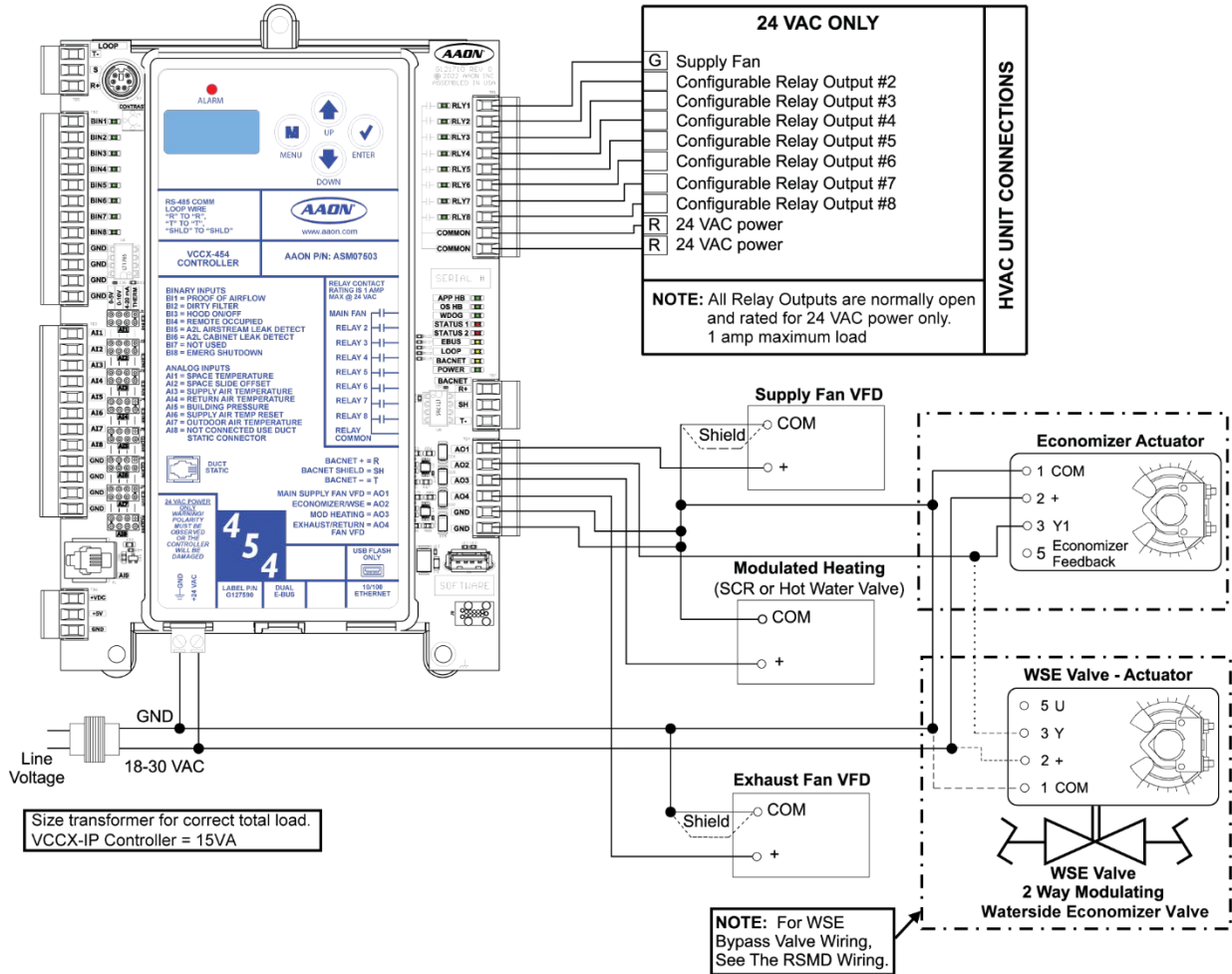

Figure 7: VCCX-454-GH Controller Outputs Wiring

6.2. Sensors

6.2.1. E-BUS Digital Room Sensor

The ASM01820 or ASM02221 E-BUS Digital Room Sensor can be used to sense space temperature and humidity. The ASM02221 does not have an LCD display or keypad. The sensor connects to the VCCX-454-GH Controller with an E-BUS cable. Up to 10 sensors can be daisy-chained together and used on a single VCCX-GH.

The E-BUS Digital Room Sensor should be mounted on the wall in an area that does not have drafts or is not exposed to direct sunlight. See Figure 8 below for wiring details.

NOTE: If using multiple E-BUS sensors or modules, the E-BUS hub or adapter board may be required.

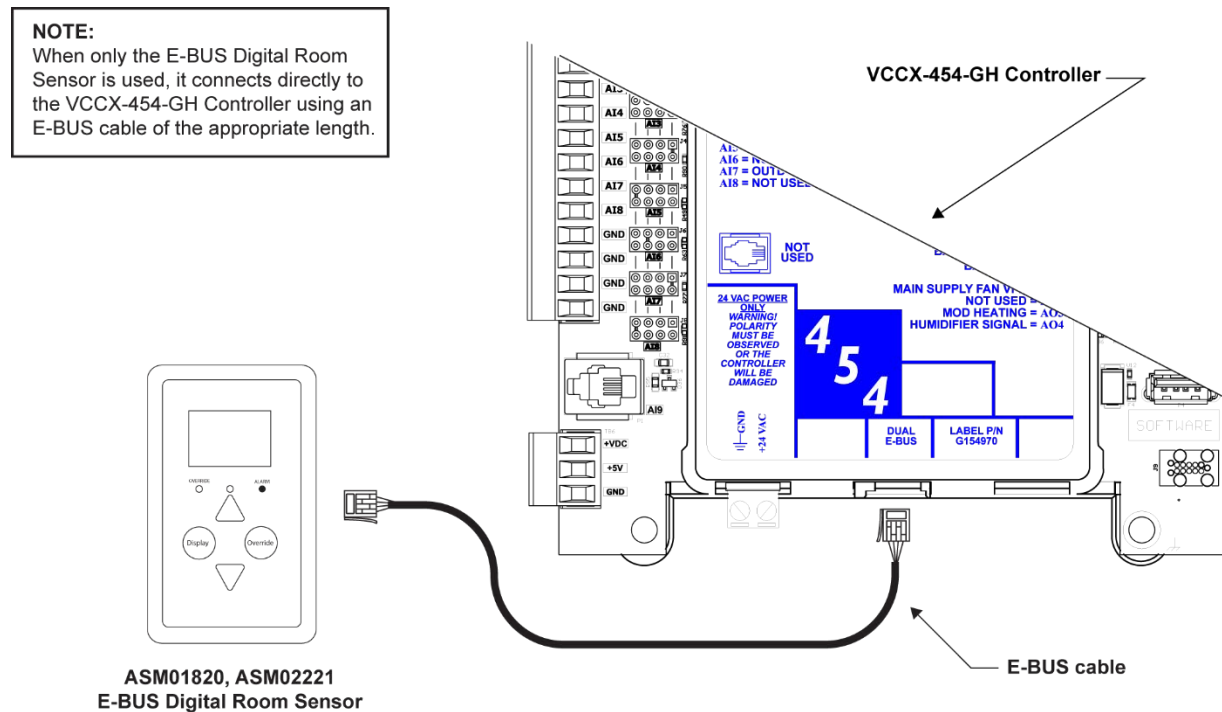

Figure 8: E-BUS Digital Room Sensor Wiring

6.2.2. Space Temperature Sensor

The ASM02227 Space Temperature Sensor can be used on units using analog space sensors instead of digital sensors. The Space Temperature Sensor is a 10K Type III Thermistor Sensor and should be mounted approximately five feet above the floor in the space that is to be controlled.

The Space Temperature Sensor is available as a sensor only.

A space temperature signal can be connected to Analog Input 1 (AI1) for applications requiring a space temperature reading.

See Figure 9 below for complete Space Temperature Sensor wiring details.

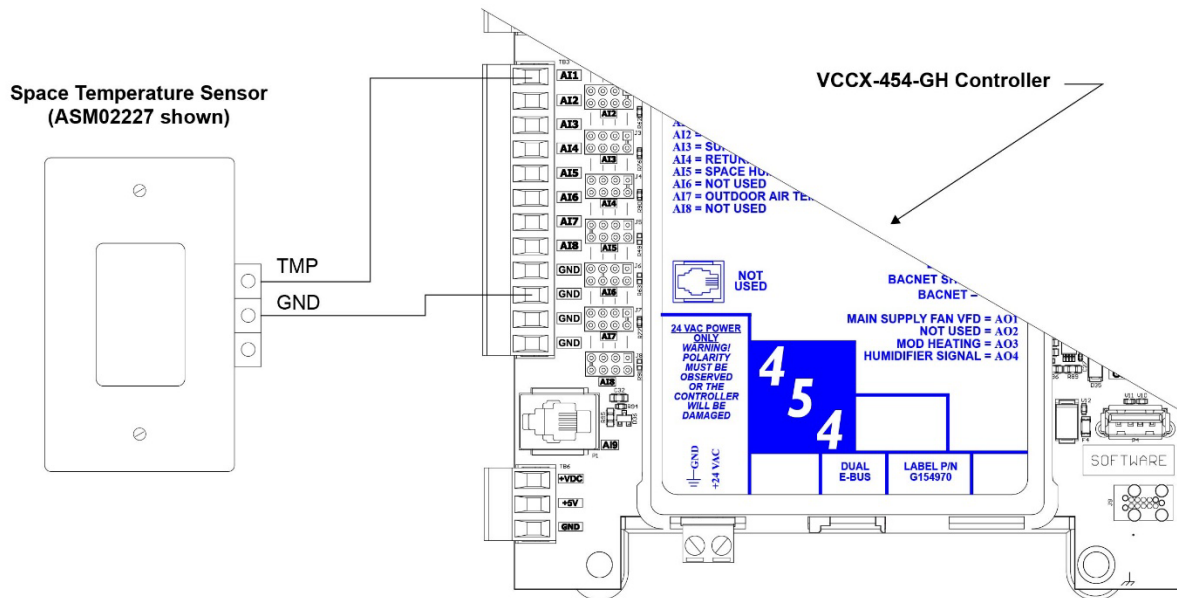

Figure 9: Space Temperature Sensor Wiring

6.2.3. Supply Air Temperature Sensor

The G051240 (6 inch) or G051250 (12 inch) Supply Air Temperature Sensor must be wired as shown for proper operation.

The Supply Air Temperature Sensor is a 10K Type III Thermistor Sensor. The Supply Air Temperature Sensor should be mounted in the unit discharge plenum or in the supply air duct.

A supply air temperature signal needs to be connected to AI3 for applications requiring a supply air temperature reading.

See Figure 10 below for details.

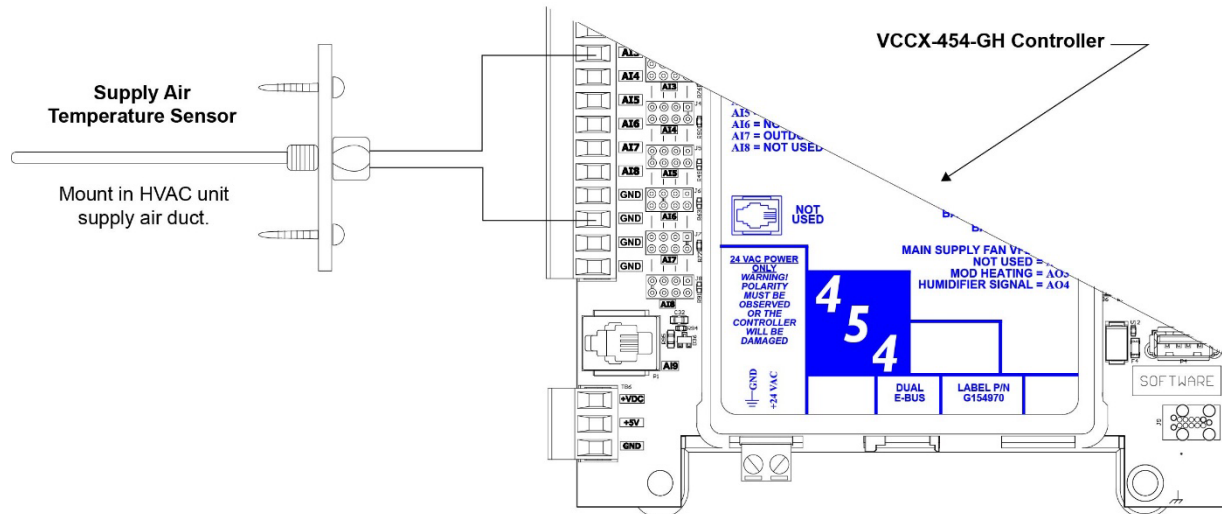

Figure 10: Supply Air Temperature Sensor Wiring

6.2.4. Return Air Temperature Sensor

G051240 (6 inch) or G051250 (12 inch) Return Air Temperature Sensor must be wired as shown for proper operation. The Return Air Temperature Sensor is a 10K Type III Thermistor Sensor. The Return Air Temperature Sensor should be mounted in the return air duct.

A return air temperature signal can be connected to AI4 for applications requiring a return air temperature reading.

See Figure 11 below for details.

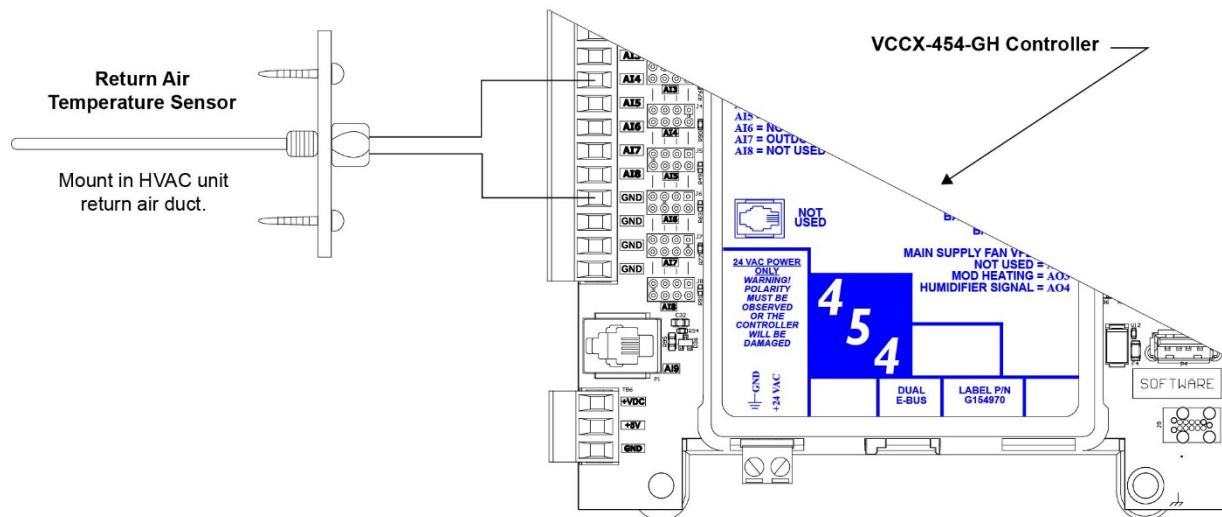

Figure 11: Return Air Temperature Sensor Wiring

6.2.5. Analog Humidity Sensor

If the VCCX-454-GH is configured to use an analog space sensor, by AAON or a third-party (0-5 V, 24 VAC), the humidity reading from the sensor on this input is used by the controller as a reference to help condition the space. The space humidity is used for the space dew point calculation.

See Figure 12 below for details.

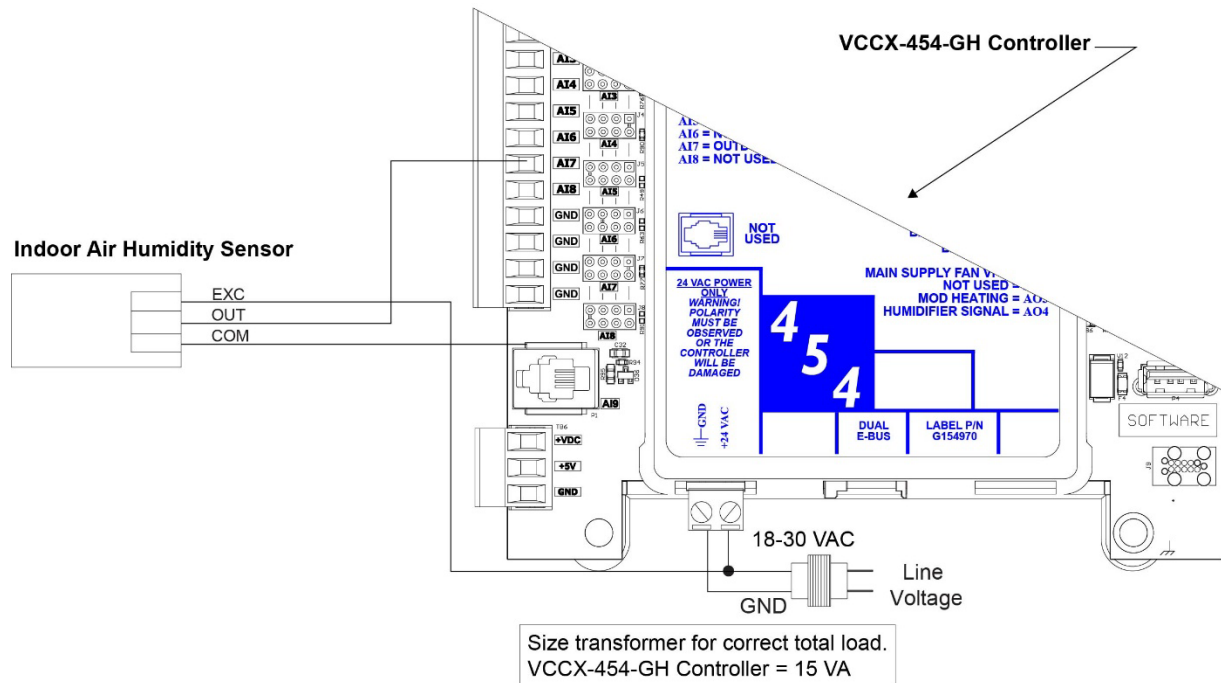

Figure 12: Analog Humidity Sensor Wiring

6.2.6. Outdoor Air Temperature Sensors

The G042330 Outdoor Air Temperature Sensor must be wired as shown for proper operation of the VCCX-454-GH Controller. The Outdoor Air Temperature Sensor is a 10K Type III Thermistor Sensor.

An outdoor air temperature signal can be connected to AI7 for applications requiring an outdoor air temperature reading.

See Figure 13 below for details.

For applications involving outdoor air humidity, the vertical or horizontal E-BUS Outside Air and Humidity Sensor must be used instead. See Figure 13 below.

CAUTION

Be sure to mount the sensor in the upright position, in an area that is not exposed to direct sunlight, and is protected from the elements. The shaded area under the HVAC unit rain hood is normally a good location. Unused conduit opening(s) must have closure plugs installed and must be coated with sealing compound to provide a rain-tight seal. Water can damage the sensor.

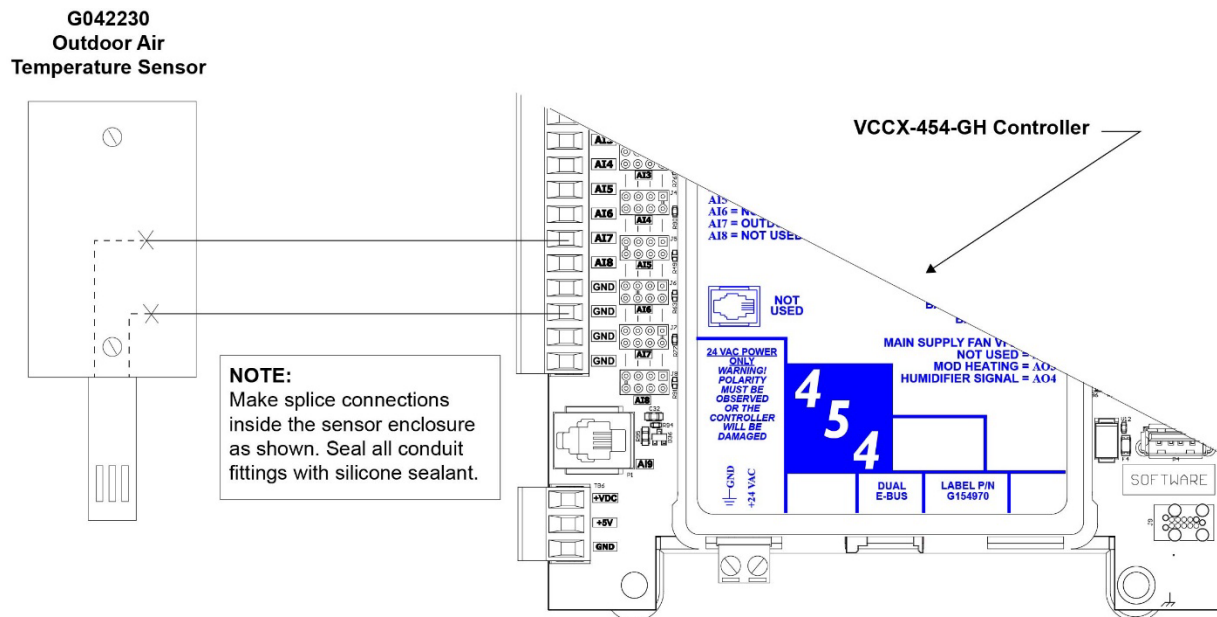

Figure 13: Outdoor Air Temperature Sensor Wiring

6.2.7. E-BUS Temperature and Humidity Sensor

The VCCX-454-GH can use both an Outdoor Air Temperature and Humidity Sensor and a Return Air Temperature and Humidity Sensor.

The ASM01836 (Horizontal) or ASM01838 (Vertical) E-BUS Outdoor Air Temperature and Humidity Sensor connects to the VCCX-454-GH Controller via a provided 25 ft. E-BUS cable, which plugs into the sensor's attached 3 ft. cable and then plugs into the E-BUS port of the VCCX-454-GH Controller or any available E-BUS port in the unit.

The ASM01840 E-BUS Return Air Temperature and Humidity Sensor connects to the Controller via the provided 50 ft. E-BUS cable.

See Figure 14 below for details.

Other cable lengths are available. See the Parts Number Cross Reference Table, page 10.

NOTE: If using multiple E-BUS sensors or modules, the E-BUS hub or E-BUS adapter board may be required.

CAUTION

Be sure to mount the outdoor sensor in the upright position, in an area that is not exposed to direct sunlight, and is protected from the elements. The shaded area under the HVAC unit rain hood is normally a good location. Unused conduit opening(s) must have closure plugs installed and must be coated with sealing compound to provide a rain-tight seal. Water can damage the sensor.

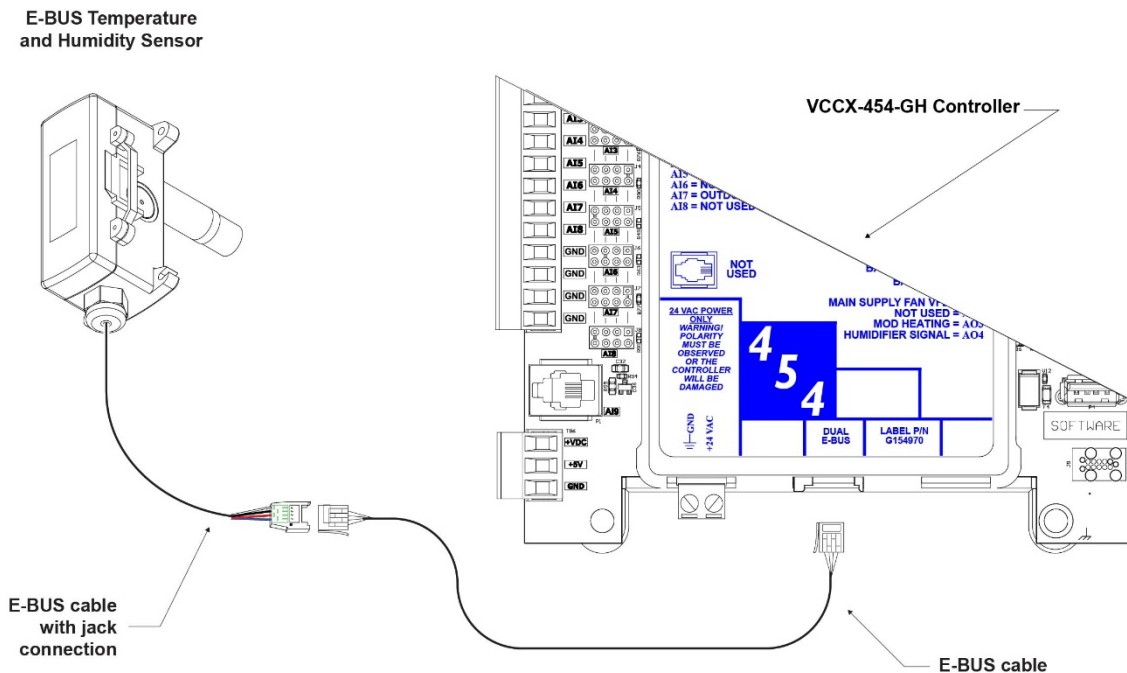

Figure 14: E-Bus Temperature and Humidity Sensor Wiring

6.3. Devices

6.3.1. Supply Fan VFD Signal

The Supply Fan VFD Signal is a user-adjustable signal with a range of 0-10 VDC from Analog Output 1 (AO1) on the VCCX-454-GH Controller. This signal output can be connected to the Supply Fan VFD to modulate the supply fan speed.

See Figure 15 below for detailed wiring.

! CAUTION

VFD units can cause large transient noise spikes, which can cause interference to be propagated to other electronic equipment. Use shielded wire wherever possible and route all sensor and controller wiring away from the VFD and the HVAC unit electrical wiring.

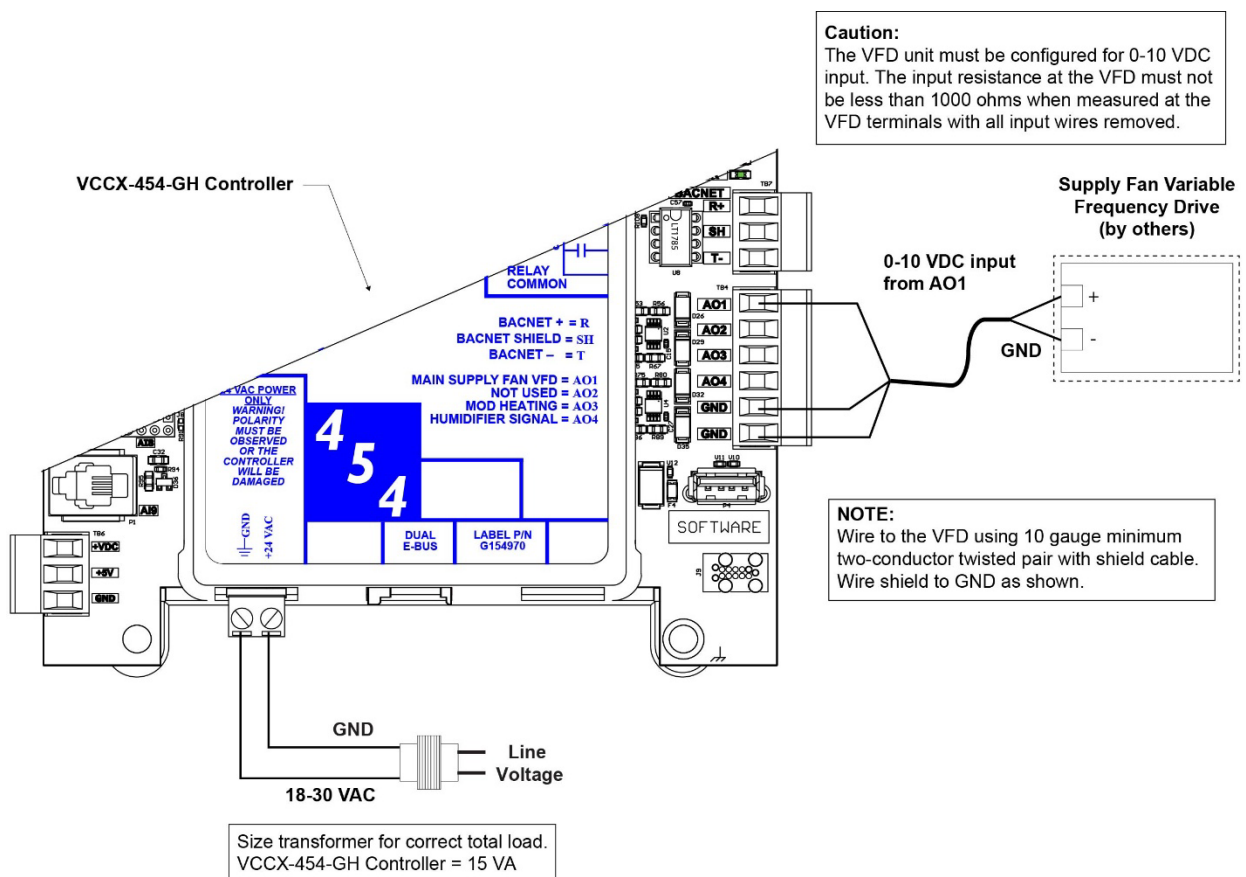

Figure 15: Supply Fan VFD Wiring

6.3.2. Modulating Heating Device

The Modulating Heating Device Signal voltage output is a user-adjustable signal with a range of 0-10 VDC from AO3 when programming the controller. The output signal can be configured for either direct acting or reverse acting operation as required.

The output signal is normally used for SCR control of an electric heating coil.

See Figure 16 below for detailed wiring of the Modulating Heating Device.

WARNING

It is very important to be certain that all wiring is correct as shown in the wiring diagram below. Failure to observe the correct polarity could result in damage to the Modulating Heating Device or the VCCX-454-GH Controller.

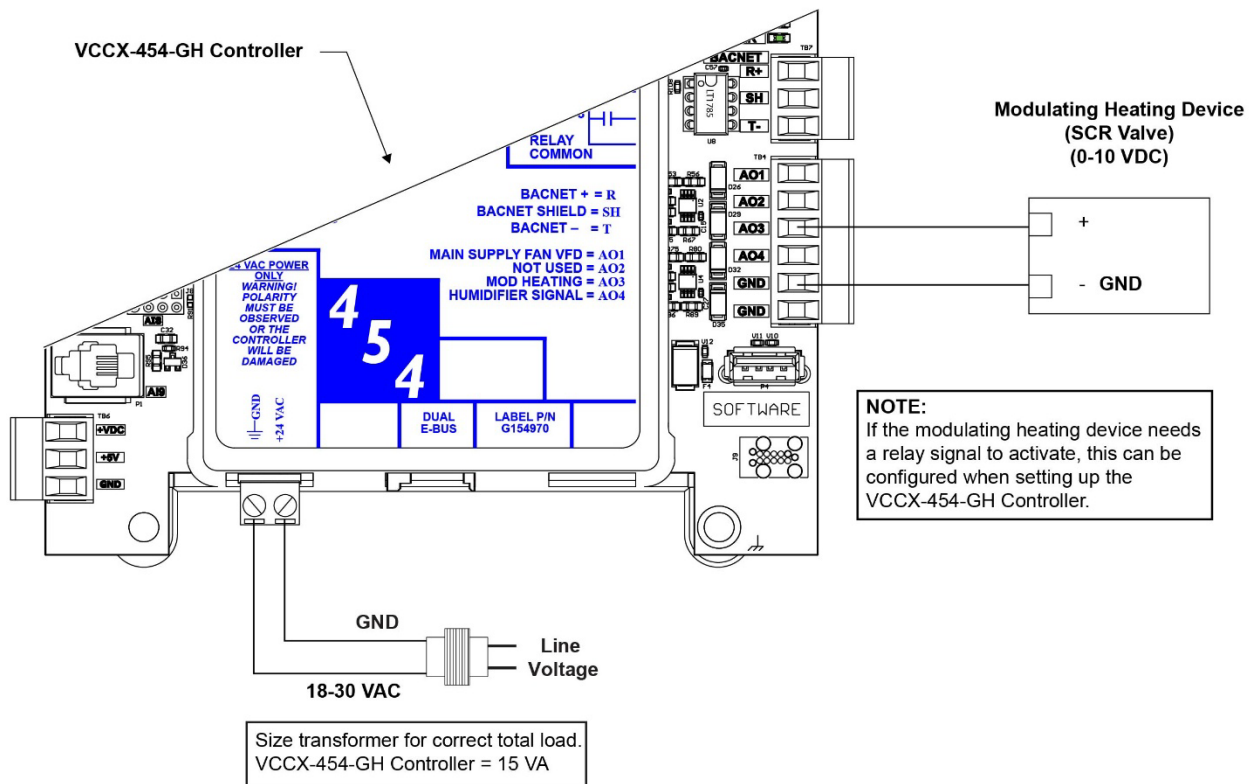

Figure 16: Modulating Heating Device Wiring

6.3.3. Humidifier

The humidifier signal voltage output is a user-adjustable signal with a range of 0-10 VDC from AO4 when programming the controller. The output signal can be configured for either direct acting or reverse acting operation as required. The humidifier is not factory installed.

See Figure 17 below for detailed wiring of the humidifier.

WARNING

It is very important to be certain that all wiring is correct as shown in the wiring diagram below. Failure to observe the correct polarity could result in damage to the humidifier or the controller.

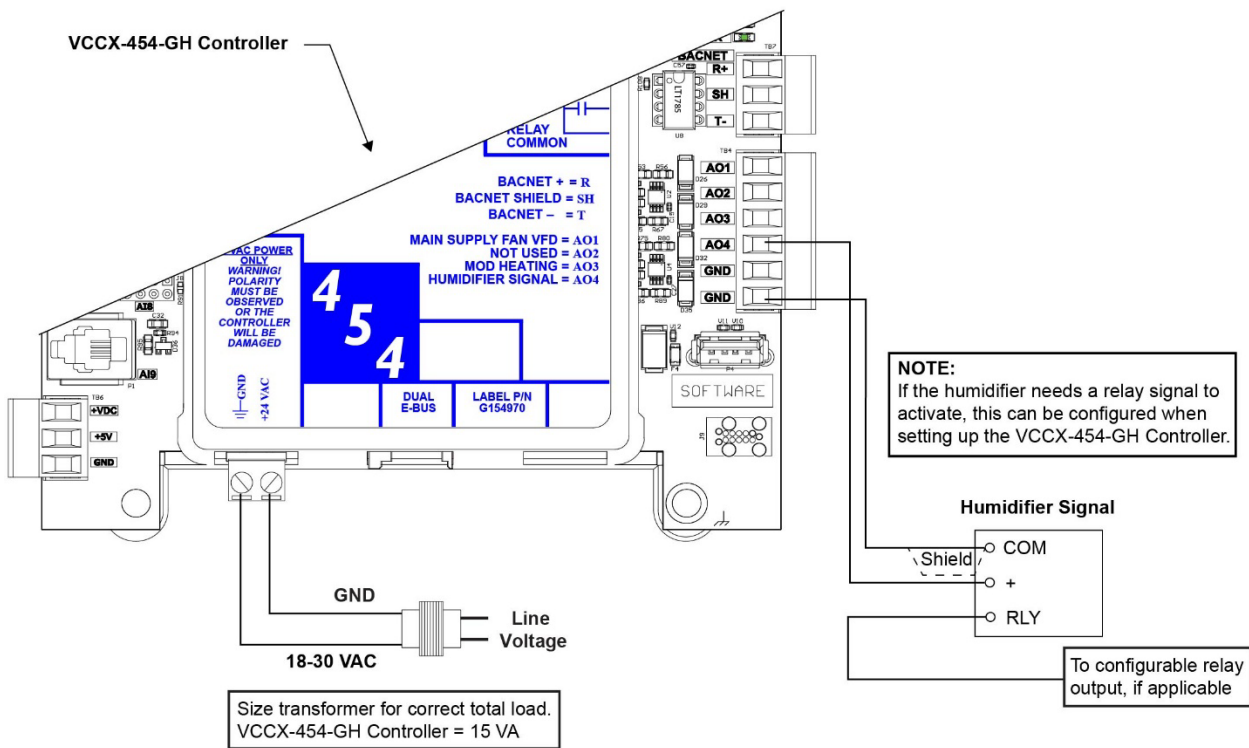

Figure 17: Humidifier Wiring

6.4. Modules

6.4.1. 12 Relay E-BUS Expansion Module

The 12 Relay E-BUS Expansion Module provides for 12 dry contact configurable relay outputs. See Figure 18 below for complete wiring details.

WARNING

Observe polarity! All boards must be wired with GND-to-GND and 24 VAC-to-24 VAC. Failure to observe polarity will result in damage to one or more of the boards. Expansion modules must be wired so that the expansion modules and the controller are always powered together. Loss of power to the expansion module will cause the controller to become inoperable until power is restored to the expansion module.

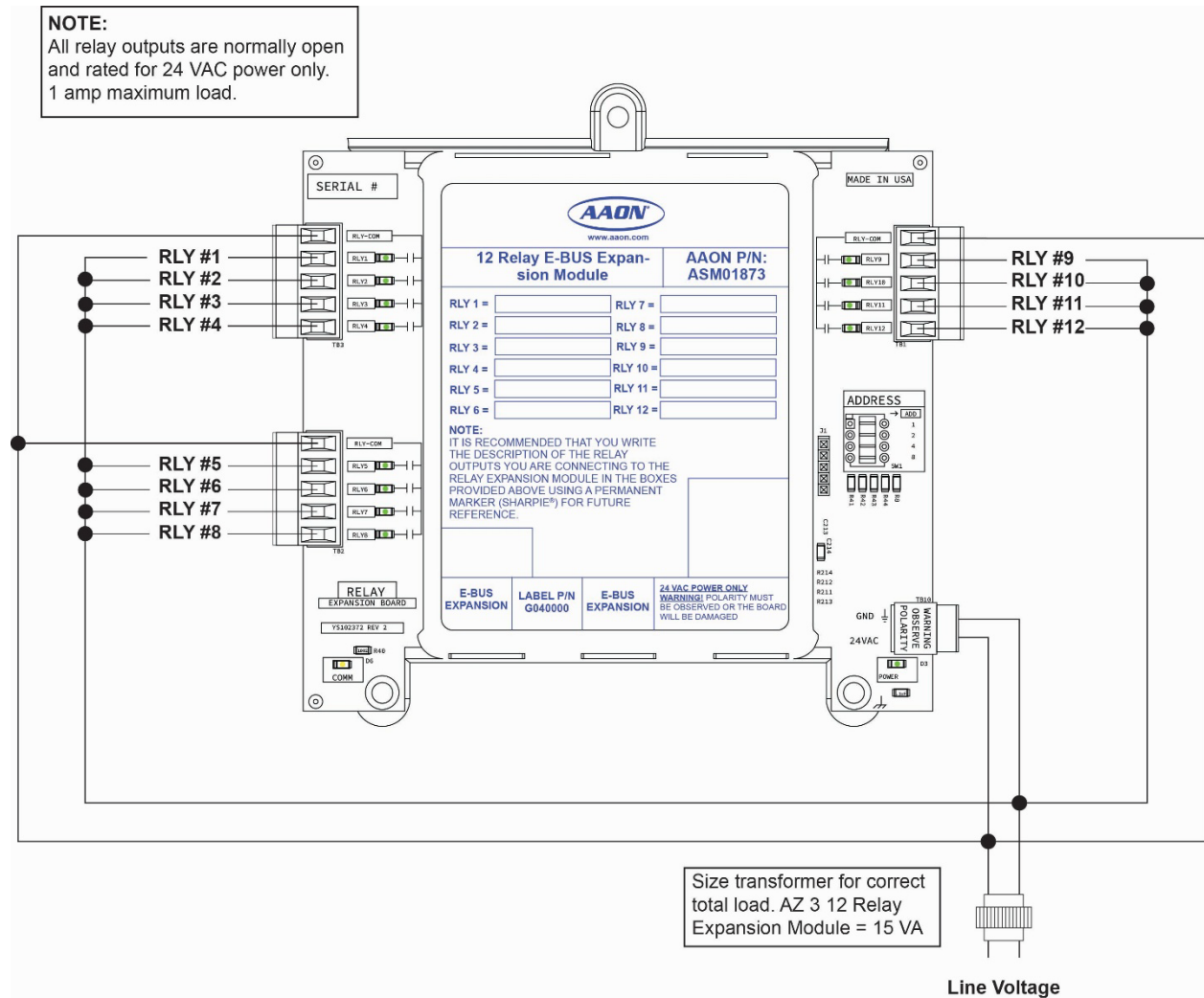

Figure 18: 12 Relay E-BUS Expansion Module Wiring

6.4.2. RSMD-GH Inputs

Each RSMD-GH can monitor and control up to two compressors and one condenser circuit. If there is more than one compressor, it will be on a tandem circuit. The module is designed for R410-A refrigerant.

The RSMD-GH is connected to the VCCX-454-GH Controller. Up to two RSMD-GH Modules can be connected, depending on the size of the system. There are two E-BUS expansion ports, which allow the use of communicating sensors and E-BUS Modules.

The RSMD-GH provides three analog inputs, four binary inputs, five relays, and two analog outputs. See Figure 19 below for the inputs wiring and Figure 20 for the outputs wiring.

Pressure Transducers

The Suction and Head Pressure Transducers must be wired as shown in Figure 19. It is typically required for all VCCX-454-GH applications.

Compressor Discharge Temperature Sensor

The digital Compressor Discharge Temperature Sensor monitors the discharge temperature from the digital compressor to protect against overheating.

! CAUTION

The Shraeder port used for installation of the Suction Pressure Transducer should be located in a vertical position of the suction line to prevent refrigerant oil from accumulating in the sensor.

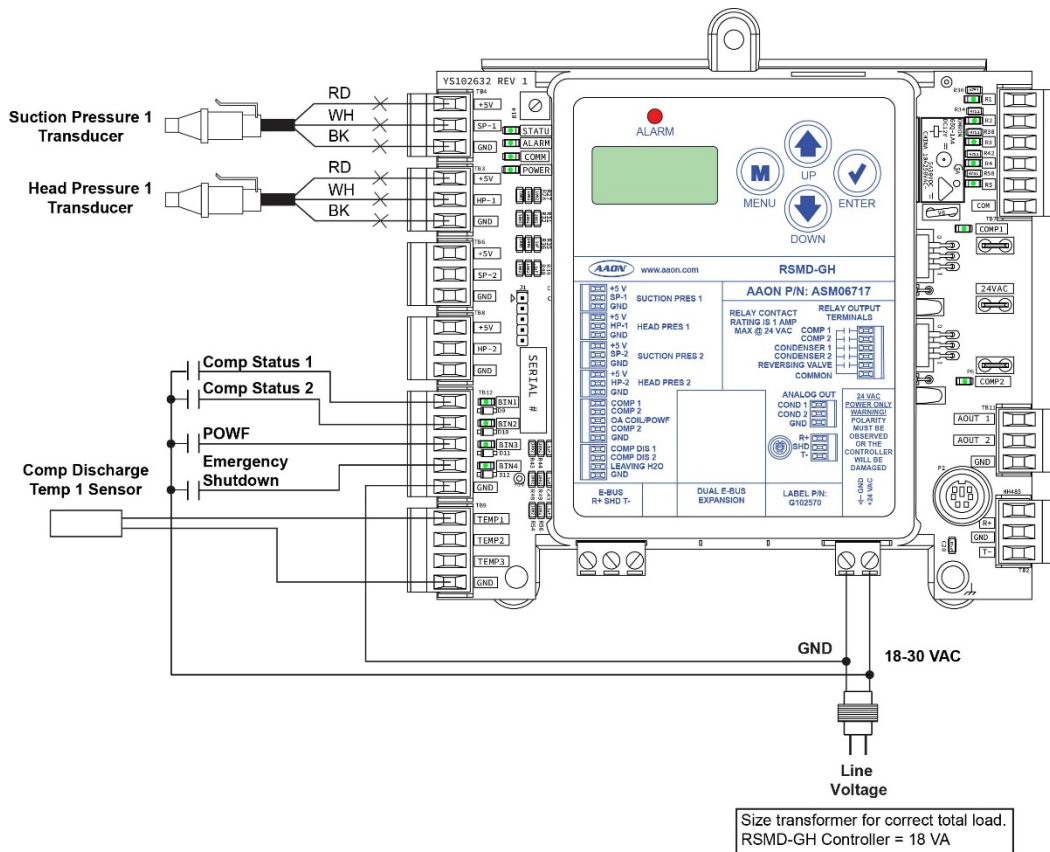

Figure 19: RSMD-GH Inputs Wiring

6.4.3. RSMD-GH Outputs

Head Pressure Control

The Head Pressure Transducers are used to measure head pressure at the discharge line. This head pressure is used to drive the condenser fans with a 0-10 VDC output signal to maintain a given Head Pressure setpoint.

Compressor Control

The compressor enable relay outputs are used to enable and disable the compressors wired to this module. The digital compressor output is used to control the loading and unloading of a digital compressor.

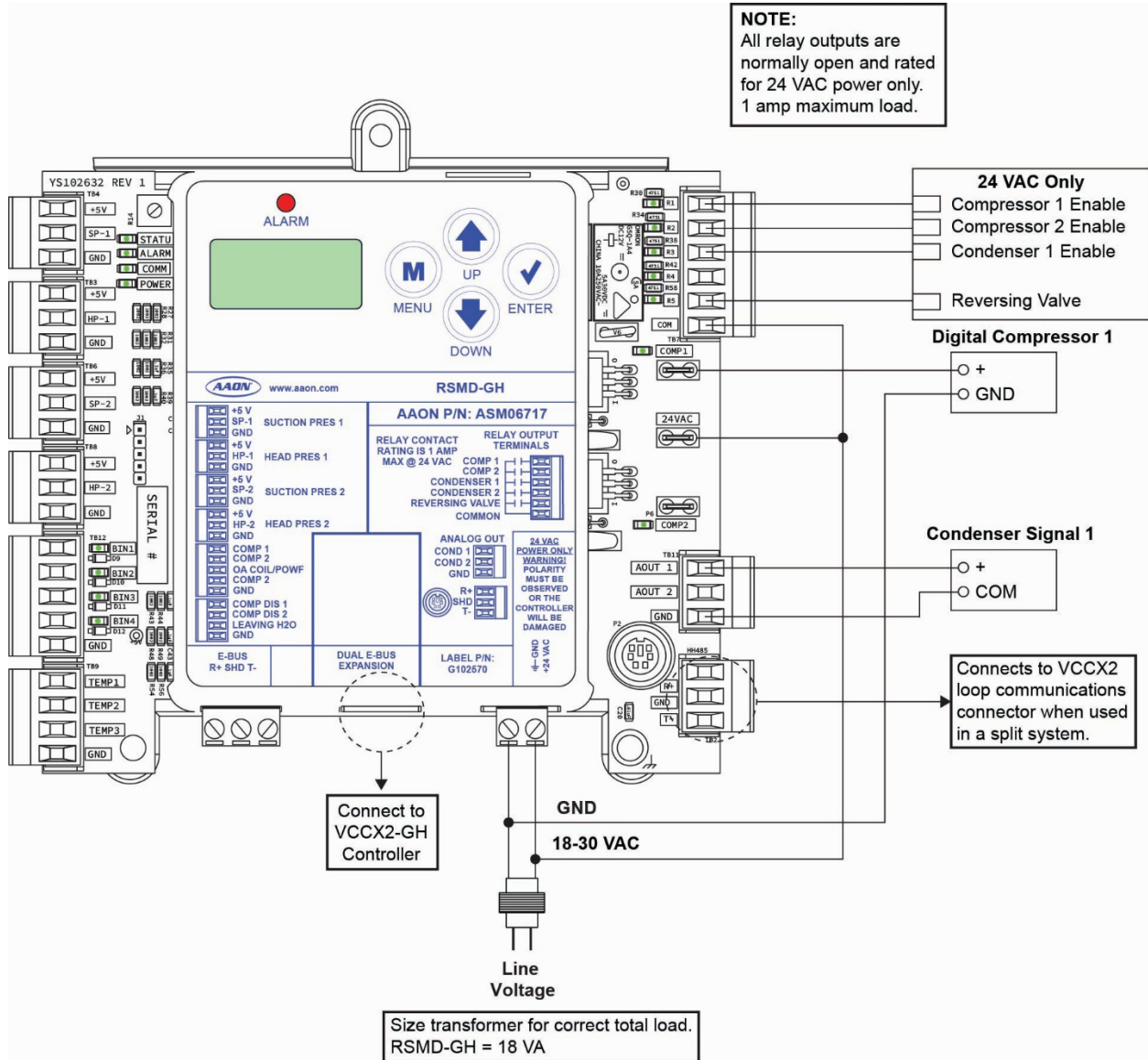

Figure 20: RSMD-GH Outputs Wiring

6.4.4. MHGRV-X Series Wiring

The MHGRV-X series modules are designed to control a modulating hot gas reheat valve to maintain a desired space temperature. In addition, the Reheat Expansion Module can be added for additional reheat valve control. The module connects directly to the VCCX-454-GH Controller or indirectly using an E-BUS Expansion Board via an E-BUS cable. See Figure 21 below.

NOTE: If using multiple E-BUS sensors or modules, an E-BUS hub or adapter board may be required.

The following information will be passed between the module and the controller:

- Reheat Enable Command
- Space Temperature Setpoint
- Current Space Temperature
- Modulating Valve Position

If the communication is interrupted between the module and the controller, the module reverts to stand-alone operation.

For more information, refer to the relevant MHGRV-X series technical guide.

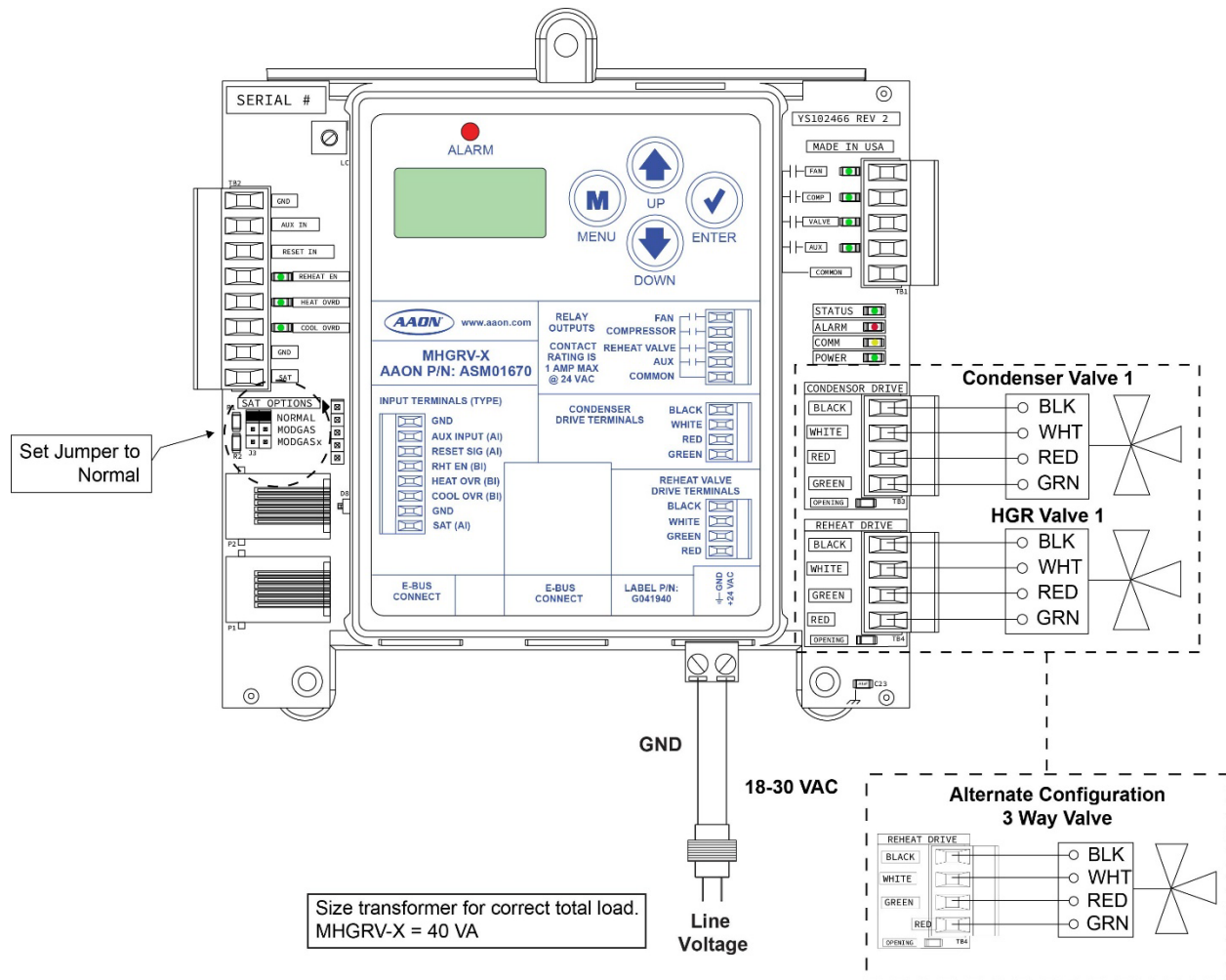

Figure 21: MHGRV-X Series Module to VCCX-454-GH Controller Wiring (MHGRV-X shown)

6.4.5. MODGAS-XWR2 Series Module Wiring

The MODGAS-XWR2 series modules are designed to be used with White-Rodgers valves only. The module modulates up to two White-Rodgers gas valves to maintain a desired discharge (supply) air temperature. Up to four modulating gas valves may be controlled when a second module is configured as a slave module. The module also controls the speed of the induced draft fan to maintain proper combustion in the heat exchanger. The module is connected to the VCCX-454-GH using an E-BUS cable. See Figure 22 below.

The following information is passed between the module and the controller:

- Heat Activation Command
- Heating Discharge Setpoint
- The Offset for the Supply Air Temperature Sensor
- High Limit Temperature Setpoint
- If the communication is interrupted between the module and the controller, the module reverts to stand-alone operation.

For more information, refer to the MODGAS-XWR2 series module technical guide.

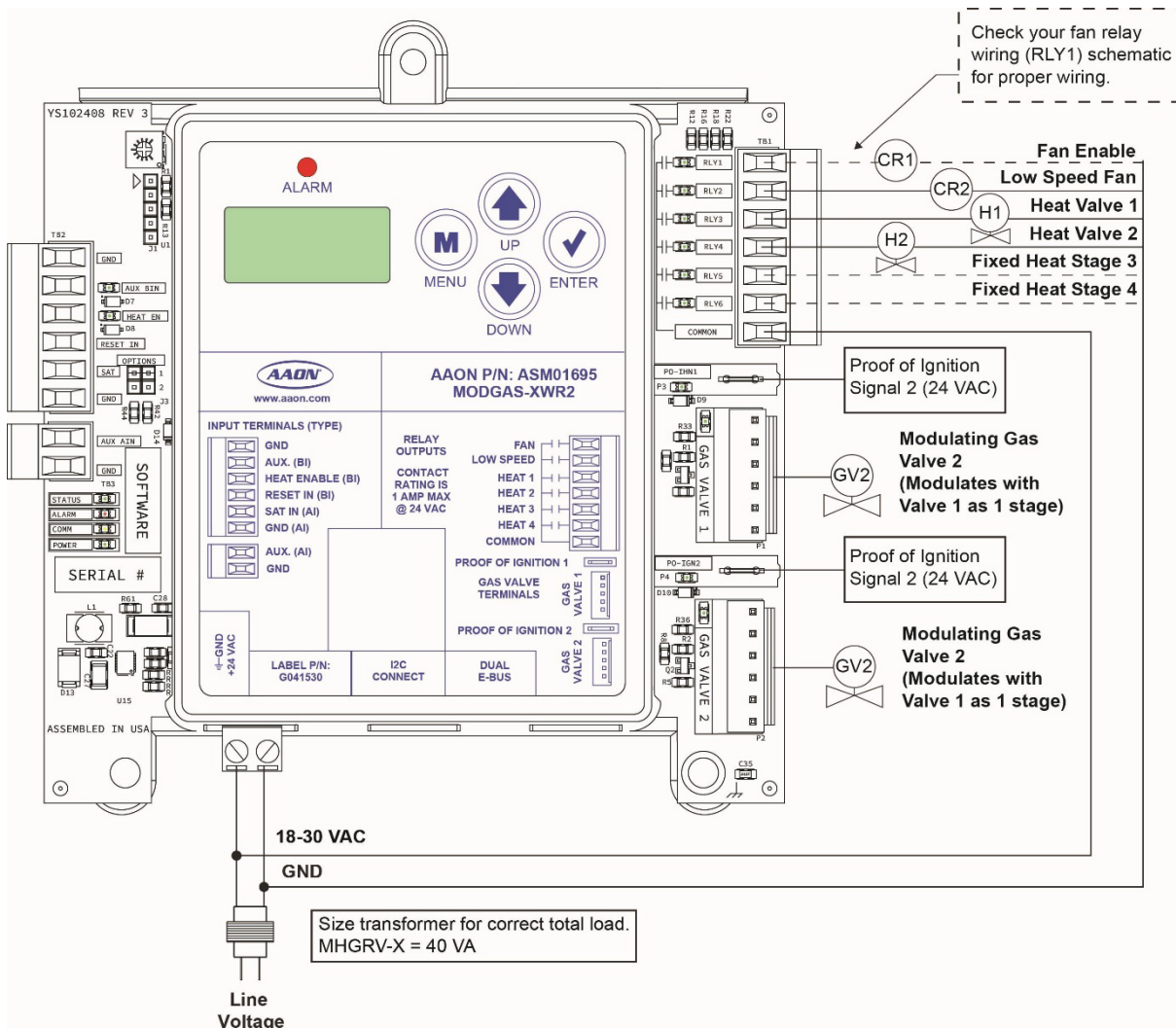

Figure 22: MODGAS-XWR2 Series Module to VCCX-454-GH Controller Wiring (MODGAS-XWR2 shown)

7. START-UP AND COMMISSIONING

7.1. Start-up and Commissioning

7.1.1. Before Applying Power

To have a trouble-free start-up, it is important to follow a few simple procedures. Before applying power for the first time, it is very important to run through a few simple checks.

7.1.2. Power Wiring

One of the most important checks to make before powering up the system for the first time is to confirm proper voltage and transformer sizing for each controller. Each VCCX-454-GH Controller requires 15 VA of power delivered to it at 24 VAC. Use separate transformers for each device (preferred), or power several devices from a common transformer.



WARNING

Observe polarity! All boards must be wired with GND-to-GND and 24 VAC-to-24 VAC. Failure to observe polarity will result in damage to one or more of the boards.

Check all wiring leads at the terminal block for tightness. Ensure that the wire strands do not stick out and touch adjacent terminals. Confirm all sensors required for the system are mounted in the appropriate location and wired into the correct terminals on the VCCX-454-GH Controller.

After all the above wiring checks are complete, apply power to the VCCX-454-GH Controller.

7.1.3. Configuring the Controller

The next step is configuring the controller for specific requirements. To configure the VCCX-454-GH Controller, use a PC with Prism 2 software installed and either a CommLink 6 or a USB-Link 2 to connect to the controller.

Prism 2 can be used to access the status, configuration, and setpoints of any controller on the communications loop.

Refer to the *Prism 2 Technical Guide*.

AAON recommends proceeding with the programming and setup of the VCCX-454-GH Controller in the order that follows:

1. Configure the controller for the application.
2. Program the controller setpoints.
3. Program the controller operation schedules.
4. Set the controller current time and date.
5. Review the controller status screens to verify system operation and correct controller configuration.

NOTE: For BACnet Configuration information, see Appendix C.

8. INPUTS AND OUTPUTS

8.1. VCCX-454-GH Controller

Table 4: VCCX-454-GH Controller Inputs and Outputs

Inputs and Outputs	
Analog Inputs (AI)	
AI1	Space Temperature
AI2	Not Used
AI3	Supply Air Temperature
AI4	Return Air Temperature
AI5	Space Humidity
AI6	Not Used
AI7	Outdoor Air Temperature
AI8	Not Used
Binary Inputs (BI)	
BI1	Proof of Airflow
BI2	Dirty Filter
BI3	Not Used
BI4	Not Used
BI5	A2L Airstream Leak Detect
BI6	A2L Cabinet Leak Detect
BI7	Not Used
BI8	Emergency Shutdown
Analog Outputs (AO) (0-10 VDC)	
A01	Main Supply Fan VFD
A02	Not Used
A03	Modulating Heating (SCR)
A04	Humidifier Signal
Relay Outputs (RLY) (24 VAC)	
RLY1	Main Fan Relay
RLY2	Configurable Relay
RLY3	Configurable Relay
RLY4	Configurable Relay
RLY5	Configurable Relay
RLY6	Configurable Relay
RLY7	Configurable Relay
RLY8	Configurable Relay

NOTE: The following E-BUS sensors and modules are available to connect to the VCCX-454-GH Controller via E-BUS ports or E-Bus Expansion Modules:

1. E-BUS Digital Room Sensor - LCD Display - Temp Only or Temp and Humidity
2. E-BUS Digital Room Sensor - No LCD Display - Temp and Humidity
3. E-BUS Outdoor Air Temperature and Humidity Sensor
4. E-BUS Return Air Temperature and Humidity Sensor



8.1.1. VCCX-454-GH Controller Inputs

Analog Inputs

AI1 - Space Temperature Sensor Input

If the VCCX-454-GH is configured to use an analog space temperature sensor, the reading from the sensor on this input is used by the controller as a reference to help condition the space. Space temperature is used for the space dew point calculation and also sent to the MHGRV-X series module so it can modulate its valve to help maintain the Space temperature Setpoint.

AI3 - Supply Air Temperature Sensor Input

Supply air temperature is used when the unit heat is active for controlling the supply air temperature to the calculated supply air setpoint. The HVAC unit must always have a supply air temperature sensor installed.

AI4 - Return Air Temperature Sensor Input

If the VCCX-454-GH is configured to use an analog space sensor, the humidity reading from the sensor on this input is used by the controller as a reference to help condition the space. Space humidity is used for the space dew point calculation.

AI5 - Space Humidity Sensor Input

If the VCCX-454-GH is configured to use an analog space sensor, the humidity reading from the sensor on this input is used by the controller as a reference to help condition the space. Space humidity is used for the space dew point calculation.

AI7 - Outdoor Air Temperature Sensor Input

The outdoor air temperature is only used to enable or disable the use of the low ambient bypass valve.

NOTE: For AI1, AI3, AI4, and AI7, all temperature sensors must be Thermistor Type III, which provide 77.0°F at 10K ohms resistance.



Binary Inputs

BI1 - Proof of Flow Input

A proof of flow switch (by others) that provides a wet contact closure whenever the HVAC unit supply fan is operating can be connected to this input. If the proof switch contact opens while the supply fan is operating, all heating and cooling is suspended or disabled.

BI2 - Dirty Filter Contact Closure Input

This wet contact input is required for filter status indication and requires a differential pressure switch to initiate a dirty filter alarm.

BI5 - A2L Airstream Leak Detect

A wet contact closure on this input is used to provide an alarm for when there is an A2L refrigerant leak in the airstream.

BI6 - A2L Cabinet Leak Detect

A wet contact closure on this input is used to provide an alarm for when there is an A2L refrigerant leak in the cabinet.

BI8 - Emergency Shutdown Input

This wet contact input is used to initiate shutdown of the HVAC unit when a normally closed smoke detector (by others), firestat (by others), or other shutdown condition (by others) contact is opened. The controller remains active and can initiate alarm relays.

NOTE: The binary inputs require wet contacts (24 VAC only) to recognize an active input. If only dry contacts are provided, the contact closure will not be recognized. All binary inputs are optional. This means the VCCX-454-GH Controller must be configured to recognize these input signals.



8.1.2. VCCX-454-GH Controller Outputs

Analog Outputs

A01 - Main Supply Fan VFD Control Signal

The user-adjustable voltage signal can be used to modulate the supply fan VFD, which affects the amount of moisture removal during Grow Mode.

A03 - Modulating Heat Control Signal

This output can be configured with a user-adjustable voltage range of operation, which can be set up to provide either a direct or reverse acting operation. When enabled, this output is used to operate a Modulating Heating Device to maintain the supply air setpoint.

A04 - Humidifier Signal

This output is controlled by BACnet commands only. The commands received via BACnet directly control this output to control a humidifier.

Relays

RLY - Main Fan (Enable)

This is a non-configurable output.

RLY - RLY20 - User-Configurable Relays

These relays are configurable by the user. Relays 9-20 are available if the 12 Relay Expansion Board is installed.

For all the available configuration options, see Table 5 below.

Table 5: User-Configurable Relay Outputs

Relay Output Options	
Relay Description	Details
Not Used	Used for relay outputs not being used.
Heating Stage	Configured for each fixed stage of heating.
Modulating Heating Enable	Configure if a 0-10 VDC modulating heat source needs a relay to enable it.
Purge	When configured, this relay activates anytime the unit is commanded to be in purge mode.
HVAC Active	When configured, this relay is active anytime the unit's operating mode is set to Active.
Alarm Indicator	When configured, this relay is active anytime it is commanded to be on via BACnet.
Humidifier Enable	When configured, this relay is active anytime it is commanded to be on via BACnet.
CO ₂ Activate	When configured, this relay is active anytime it is commanded to be on via BACnet.
Electric Defrost Activate	This option is not currently used.



9. SEQUENCE OF OPERATIONS

9.1. Mode of Operation

9.1.1. Supply Fan Operation

When changing the Mode of Operation to active, or upon power-up, the controller initiates a user-adjustable fan start delay to provide a staggered start for systems with several HVAC units.

If a supply fan is off and receives a start request, it must have been off for at least one minute before it can run again. If the minimum off time is satisfied, the supply fan relay is activated while all other outputs are kept off until their minimum off time is satisfied.

The supply fan can be configured to modulate between maximum and a minimum percentage based on the refrigerant system operation. If all compressors are operating at maximum capacity and the saturation temperature is above the coil setpoint, the fan speed is modulated down in 5% decrements until the coil setpoint is satisfied or the output reaches the minimum fan speed setpoint value. If the compressors start to decrease operating capacity, the fan speed increases.

The supply fan speed can also be controlled using a BACnet override.

9.1.2. HVAC Modes of Operation

There are seven possible HVAC modes of operation. They are as follows:

- Off Mode
- Grow Mode
- Dry Mode
- Fan Mode
- Cool Mode
- Heat Mode
- Purge Mode

Off Mode

Off mode is the state of turning off everything in the system in a controlled manner to prevent damage to the equipment. If Off Mode is entered as a result of the deactivation of the Emergency Input, an orderly shutdown of equipment still occurs; however, all minimum run times for equipment are ignored.

Grow Mode

Grow Mode operates the unit to control the desired space dew point, calculated from the Space Temperature Setpoint and the Space Humidity Setpoint. If the controller cannot maintain the required space dew point, the controller may reduce the main fan speed to improve dehumidification. The controller also modulates the reheat controller to maintain the space temperature setpoint. If necessary, and if the system is configured to allow unit heat to supplement reheat, the controller activates unit heat to control the space temperature to the setpoint.

Dry Mode

Dry Mode operates similar to Grow Mode with two key exceptions:

- Dry Mode allows the evaporation coil target temperature to drop below freezing.
- Dry Mode adds frost monitoring and defrost cycles to the operational sequence.

Fan Mode

Fan Mode operates the main fan at 100% capacity but does not operate any other conditioning equipment.

Cool Mode

Cool Mode operates the main fan at 100% capacity and operates the refrigeration equipment to target the Space Temperature Setpoint. Unlike the Grow Mode, this mode ignores the Space Humidity Setpoint and does not operate reheat or unit heat.

Heat Mode

Heat Mode is only available if the unit was selected to have unit heat. Heat Mode operates the main fan at maximum speed and modulates the unit heat to maintain the Space Temperature Setpoint. This mode ignores the space humidity setpoint and does not operate the refrigeration system or reheat.

Purge Mode

Like Fan Mode, Purge Mode operates the main fan at maximum speed and does not operate any other condition equipment. Additionally, Purge Mode activates the Purge relay, which can be used to open an outside air damper or activate an exhaust fan.

9.1.3. Compressor Operation

Compressors are wired to and controlled by the RSMD-GH. When the unit is running in Grow, Dry, or Cool modes, the active compressors control the saturated suction temperature to the Coil Setpoint. The Coil Setpoint is reset based on the space conditions.

When in Grow or Dry Mode, the Coil Setpoint resets lower if the space dew point is above the desired dew point. It resets higher if the space dew point is lower than the desired dew point. In Cool Mode, the Coil Setpoint resets lower if the space temperature is higher than the Space Temperature Setpoint and higher if it is below the Space Temperature Setpoint.

Additional compressors stage on when the active compressors are at full capacity, and the space dew point is above the desired dew point. A compressor stages off if the active compressors are at minimum capacity and the space dew point is below the desired dew point.

During Grow and Dry Modes, at least one compressor runs to maintain space conditions. In Cool Mode, if the space temperature drops below the Space Temperature Setpoint and a single compressor is running at minimum capacity for a stage down relay, the compressor stages off.

9.1.4. Condenser Operation

The condenser section of the unit is also wired to and controlled by the RSMD-GH. On air-cooled units, condenser fans are used to control the discharge pressure of the refrigerant circuit. On water-cooled units, valves are used to control water flowing through the condenser section to control the discharge pressure. Head pressure transducers are wired to the RSMD-GH to monitor the discharge pressure. In Grow and Dry Mode, the condenser signal modulates to maintain the Head Pressure Setpoint. In Cool Mode, the condenser signal modulates to maintain the Head Pressure Setpoint.

9.1.5. Low Ambient Bypass Valve Operation

On units with low ambient bypass valves installed, the LA Auxiliary board modulates the bypass valves to a saturated Liquid Temperature Setpoint to help keep the compressors running in their operating envelopes. The Liquid Temperature Setpoint is reset based on where the refrigerant circuit is operating in the envelope.

9.1.6. Reheat Operation

During the Grow Mode, the VCCX-454-GH activates cooling to extract moisture from the space temperature and utilizes either modulating hot gas reheat or heating to reheat the supply air. Hot gas reheat is the standard form of reheat.

If the unit is equipped with an MHGRV-X series module, during Grow Mode, it modulates the reheat valve has reached 100% capacity and the heating stage up delay has been met. Once the unit heat is activated, the modulating reheat valve is locked at its maximum position.

If the space temperature goes above the Space Temperature Setpoint, the unit heat stages off if it reaches its minimum capacity and stays there for a stage down delay. The modulating reheat valve then modulates to control the space temperature.



WARNING

Simultaneous heating and cooling cannot be approved unless the HVAC unit has been specifically designed for this purpose. A Special Purchase Authorization must be obtained from the AAON factory for these applications to avoid warranty and/or rating problems. AAON assumes no liability for any simultaneous heating and cooling application if a Special Purchase Authorization is not obtained from the AAON Factory at the time the HVAC unit is ordered.

9.2. Heating Operation

9.2.1. Heating Operation

Available heating options are staged gas, modulating gas, staged electric, and modulating SCR electric.

In the Heat Mode, as the supply air temperature falls below the active Supply Air Temperature Setpoint, the heating begins to stage on or to modulate. Each stage must meet its minimum off time (adjustable) before it is allowed to energize, and successive stages are subject to a heating stage-up delay (adjustable).

Heating stages continue to run until the supply air temperature rises above the active Supply Air Setpoint plus the heating stage control window, at which point the heating begins to stage off. Each stage must meet its minimum run time (adjustable) before it is allowed to stage off, and successive stages are subject to a heating stage down delay (adjustable).

Modulating Heating

The VCCX-454-GH modulates the heat source to achieve the active supply air temperature setpoint.

The modulating heating proportional window is used to modulate the heat and is user-adjustable. The maximum signal adjustment per time period is 10% and is not user-adjustable.

The minimum signal adjustment per time period is based on the modulating heating proportional window. The larger the modulating heating proportional window, the smaller the signal adjustment per time period. The time period is user-adjustable.

Primary Modulating Heat with Secondary Staged Heat

The modulating heat source can be modulating gas or SCR electric heat. In this case, the modulating heat is the first form of heat used and attempts to achieve the active supply air temperature setpoint. If the modulating heat reaches 100%, the heating stage up delay begins. If the primary heat source is still at 100% after the heating stage up delay expires, the secondary heat source activates. The primary heat sources can then modulate as necessary to achieve the active supply air temperature setpoint. If there are additional stages of heat, they stage up as described, with the primary heat source modulating as necessary.

If the secondary heat source is activated and the primary heat source has modulated to 0%, the heating stage down delay begins. If the primary heat source is still at 0% after the heating stage down delay expires, the secondary heat source deactivates. If there are multiple stages of secondary heat, they stage off in the same manner. Then, if the supply air temperature rises above the active supply air temperature setpoint plus the heating stage control window, the primary heat source modulates to 0% to allow the supply air temperature to cool off.

9.3. Space Sensor Options

9.3.1. Space Sensor Options

Analog Space Sensors

If the VCCX-454-GH is configured to use Analog Space sensors, the Controller uses a thermistor type sensor for temperature and a 0-5 V Sensor for relative humidity readings.

Digital Space Temperature and Humidity

If the Digital Space Temperature and Humidity Sensor is configured, the controller gets its temperature and relative humidity readings from an E-BUS Digital Space Sensor or Emulator Board. Up to 10 Digital Space Temperature and Humidity Sensors can be connected to the VCCX-454-GH Controller. When multiple sensors are used, the controller can be configured to use the average readings from all sensors or the highest readings.

Reads Space Temperature and RH Global Broadcast

If the Reads Space Temp sensor is configured, the space temperature and humidity readings are broadcast on the local communication loop the controller is on.

Remote Sensor

If the Remote Sensor is configured, the controller uses the temperature and humidity readings from a specific VCCX-454-GH controller on the local communications loop.

BACnet Space Temp and Humidity

If the BACnet Space Temp and Humidity is configured, the controller uses the temperature and humidity values that are sent to it over BACnet. The controller can also be configured to use readings from its Digital Space Temperature and Humidity Sensor if it loses the reading from BACnet.

9.3.2. Temperature Protection

Temperature protection is activated when the supply air temperature rises above the high cutoff temperature (immediate) or drops below the low cutoff temperature (for 10 minutes). Both cutoff setpoints are user-adjustable. When the high cutoff protection occurs, the unit disables all heat outputs and allows the supply fan to continue to run. When the low cutoff protection occurs, the unit shuts down.

This operation is canceled when the supply air temperature drops 5°F below the high cutoff temperature setpoint or rises 5°F above the low cutoff temperature setpoint.

9.3.3. System Broadcasts

The VCCX-454-GH Controller can be configured to broadcast outdoor air temperature, outdoor air humidity, space temperature, and space humidity to any VCCX-454-GH Controller that does not have one or more of these sensor(s). A CommLink 6 or MiniLink PD 5 is required to broadcast these values.

9.4. Alarms

9.4.1. Alarm Detection and Report

The VCCX-454-GH Controller continuously performs self-diagnostics during normal operation to determine if any operating failures have occurred. These failures (alarms) can be reported to a computer running Prism 2 software.

The following are the available alarm designations for the VCCX-454-GH Controller:

- Bad SAT Sensor
- Bad RAT Sensor
- Bad OAT Sensor
- Bad Space Sensor
- Mechanical Heating Failure
- Fan Proving Alarm
- Dirty Filter Alarm
- Emergency Shutdown
- High Control Temperature
- Low Control Temperature
- Missing MHGRV-X
- Missing MODGAS-XWR2
- Missing 12RLY
- High Supply Temperature
- Low Supply Temperature
- High Control Relative Humidity
- Low Control Relative Humidity
- Missing RSMD #1
- Missing RSMD #2
- Missing RSMD #3
- Missing RSMD #4
- Missing LA Aux Module #1
- Missing LA Aux Module #2

9.4.2. Sensor Failure

Supply Air Sensor

The Supply Air Sensor Alarm is generated when the controller detects an open or short circuit on the Supply Air Sensor input. Once the alarm is generated, the unit completely shuts down. If a sensor is properly detected after the unit has generated an alarm, the alarm is cleared, and the unit restarts operations.

Return Air Sensor

This alarm is generated if the controller is configured to have a Return Air Sensor but does not detect it.

Outdoor Air Sensor

The Outdoor Air Sensor Failure Alarm is generated when the controller detects an open or short circuit on the Outdoor Air Sensor input. When this occurs, the outdoor air reading displays as 0°F.

If a Digital Outdoor Temperature and Humidity Sensor is configured, the controller keeps the last reading it received from the sensor if it worked at power up. If the digital sensor did not work at power up, the controller displays 70°F. This allows cooling and heating to continue operating.

For MUA systems, the Outdoor Air Temperature Sensor is the controlling sensor (Mode Enable Sensor). This alarm forces the MUA into Heat Mode.

Space Sensor Fail Shutdown

If the controller detects an open circuit, a short circuit, or a missing E-BUS Digital Space Sensor, then a Space Temperature Sensor Failure Alarm is generated. If this alarm is generated, the unit shuts down. This alarm is also generated if the unit is configured to use space values sent via BACnet and it fails to receive them.



9.4.3. Mechanical Failure

Heating Failure

This alarm is generated on units configured for Staged Heat Only if the supply air temperature does not change by 5°F in 15 minutes after a heat stage is activated. On units configured to have the MODGAS-XWR2 series module, this alarm is generated whenever there are any active alarms on the module.

Fan Proving Failure

This alarm is generated, and the heating and cooling are disabled if the Proof of Flow Switch is open while the fan is being called to run. Fan Proving needs to be configured for this alarm to generate. This alarm has a 30 second delay.

Dirty Filter Alarm

A Dirty Filter Alarm is generated if the differential pressure switch closes. The dirty filter needs to be configured for this alarm to generate.

Emergency Contact

The controller shuts down and generates this alarm if contact opens for a normally closed smoke detector, firestat, or other shutdown condition. If an HVAC active relay is configured, it remains energized. BACnet override commands are canceled if this emergency alarm is activated.

9.4.4. Failure Modes

High Supply Temp Alarm

If the supply air temperature rises above the user-adjustable High Supply Air Temperature Cutoff Setpoint, heating is immediately deactivated, and a High Supply Temp Alarm is generated. The fan continues to run. This mode and alarm are canceled if the supply air temperature falls below the High Supply Air Temperature Cutoff Setpoint by 5°F.

Low Supply Temp Alarm

Once the supply air is below the low sat cut off, that timer of 10 mins (adj.) begins. The fans, heating, cooling, and damper will continue to operate at that time in an attempt to raise the supply air temperature. After the 10-minute timer has elapsed and the supply air temperature is still below the low sat cut off, then the unit will proceed to shut down unit operations, including the fan, damper, and mechanical cooling and heating.

High Control Temp Failure

When the space temperature rises above the Space Temperature Setpoint plus the Space Temperature High Alarm Offset Setpoint for 15 minutes, the controller generates a High Control Temp Failure Alarm. The offset setpoint is user-adjustable.

Low Control Temp Failure

When the space temperature drops below the Space Temperature Setpoint minus the Space Temperature Low Alarm Offset Setpoint for 15 minutes, the controller generates a Low Control Temp Failure Alarm. The offset setpoint is user-adjustable.

High Control RH Failure

When the space relative humidity (RH) rises above the Space Humidity Setpoint plus the Space Humidity High Alarm Offset Setpoint for 15 minutes, the controller generates a High Control RH Failure Alarm. The offset setpoint is user-adjustable.

Low Control RH Failure

When the space RH drops below the Space Humidity Setpoint minus the Space Humidity Low Alarm Offset Setpoint for 15 minutes, the controller generates a Low Control RH Failure Alarm. The offset setpoint is user-adjustable.

9.4.5. Expansion Boards

If the controller is configured to have any of the following modules, but the controller does not detect that board, then the applicable alarm is generated. If the board is properly detected after the unit has generated the alarm, the alarm is cleared.

- Compressor Module #1
- Compressor Module #2
- Compressor Module #3
- Compressor Module #4
- MHGRV-X Module
- MODGAS-XWR2
- 12 Relay Expansion Module
- LAC Module #1
- LAC Module #2

9.5. Trend Logs

9.5.1. Using Trend Logs

The controller maintains a trend log of information points, which are refreshed at a user-defined timed intervals, from one to 120 minutes. This represents a snapshot of the system status at the moment of capture. These values can only be retrieved using Prism 2.

If information is captured once every minute, the log represents system status for the last 120 minutes, or two hours. Once these rows are full, the controller begins overwriting the oldest data.

The log only maintains 120 rows (values) for each status point. Status points include:

- Binary inputs, such as proof of airflow
- Analog inputs, such as space temperature
- Relay outputs, such as the main fan relay
- Analog outputs, such as the humidifier signal

NOTE: The status points are described in Table 6, page 61.

1. From the **Status** screen of the controller in Prism 2, click **<Details Viewer>**.



Figure 23: Prism 2 Details Viewer Button

2. On the **Details Viewer** screen, click **<Trendlogs>** and choose **<Standard Log>**.

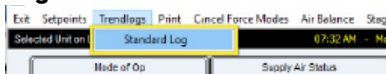

Figure 24: Standard Log Dropdown Button

3. On the **Trendlogs** screen, click **<Load LOG>**

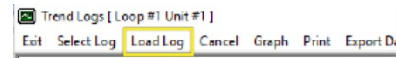

Figure 25: Load Log Option in the Trend Logs Screen

4. In the message area in the lower left of the screen, "Loading Log Data Packet#**1**" will start counting up.

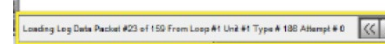

Figure 26: Location of Loading Log Data Ticket Number

5. When it is complete, the screen fills with data from the controller.
6. From this screen, click **<Export Daily>**.

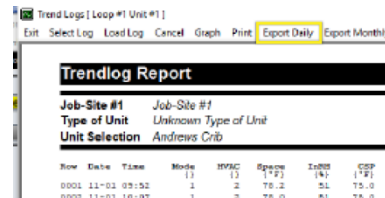

Figure 27: Export Daily Button Generates Report

7. Name the file and click **<Save>**. The system defaults to saving the file as a CSV in C:\PrismII.

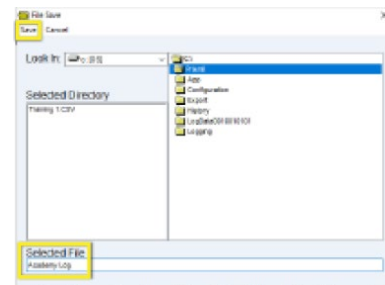

Figure 28: Saving the Report to the Computer

8. In Windows Explorer, locate the file and double click to open the file in Microsoft Excel.

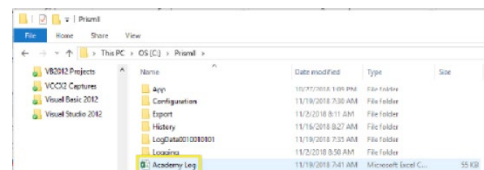

Figure 29: Opening the File

9. All data points are visible in the spreadsheet.

9.5.2. Enumerated Values

Some trend log status points are expressed as enumerated values. For example, if the value of the HVAC status point reads 1, the HVAC is in Grow Mode. See Table 7, page 61.

9.5.3. Bit String Decoding

NOTE: This section is not intended to be a full explanation of how bit strings work, but to explain how to decode the VCCX-454-GH trend log items that are indicated as being bit string values.

Some trend log status points are expressed as bit strings. Bit string values allow the manipulation of binary data in useful ways. For instance, a single trend log item may need to represent multiple simultaneous true conditions. A single bit value can be decoded to determine which multiple conditions might be simultaneously true.

1. With any trend log value that is designated to be a bit string value, simply identify from the trend log section in this technical guide what the bit string values are for each status condition and perform the following calculation.
2. Identify the highest value shown in the appropriate Trend Log Bit Strings Table that can be subtracted from the trend log bit string value. That item is currently active.
3. From the remainder, subtract the next highest possible number. That item is also active.
4. Continue in this manner until there is no remainder, indicating there are no more items that are active.

Example

The following example demonstrates how to determine active items in Alarm Group 2 (AlmGrp2) when a trend item was recorded.

VCCX-454-GH Trend Log Bit Strings		
Log Item	Value	Description
AlmGrp2	1	Not Used
	2	Mechanical Heating Alarm
	4	Fan Proving Alarm
	8	Dirty Filter Alarm
	16	Emergency Shutdown Alarm

NOTE: Excerpt from Table 6

1. If the trend log bit string value is 22 for Alarms, first identify the highest value shown above that can be subtracted from 22. In this example, that would be 16 (Emergency Shutdown). The Emergency Shutdown Alarm is currently active.
2. From the remainder of 6 ($22 - 16 = 6$), subtract the next highest possible number. That would be 4 (Fan Proving). The Fan Proving Alarm is currently active.
3. From the remainder of 2 ($6 - 4 = 2$), subtract the next highest possible number, which is 2 (Mechanical Heating). The Mechanical Heating Alarm is also currently active.
4. There is no remainder ($2 - 2 = 0$), so there are no more inputs that are active.

With this example, from one value of 22, the formula above determined that three alarms were active when that trend item was recorded.

The tables on the following pages provide the values and descriptions for the various points on the VCCX-454-GH Controller and associated modules.

9.5.4. VCCX-454-GH Trend Logs

Tables 6, 7, and 8 describe the status points, enumerated values, and bit strings available in the VCCX-454-GH trend log.

Table 6: VCCX-454-GH Trend Log Status Points

VCCX-454-GH Trend Log Status Points					
Log Item	Unit	Item Description	Log Item	Unit	Item Description
Date	Day Month	Date	FanVFD	%	Main Fan Speed VFD Signal
Time	24 Hr.	Time	ModHeat	%	Modulating Heat Signal
Mode	Enumerated	Mode of Operation	SpcDP	°F	Space Dew Point
HVAC	Enumerated	HVAC Mode	DewptSP	°F	Dew Point Setpoint
Space	°F	Space Temperature	LACVlv1	%	LAC Valve 1 Position
InRH	%	Indoor Humidity	LiqPr1	PSI	Liquid Pressure 1
CSP	%	Cooling Setpoint	LiqTmp1	°F	Liquid Temperature 1
RHSP	°F	Relative Humidity Setpoint	LACVlv2	%	LAC Valve Position 2
SAT	°F	Supply Air Temperature	LiqPr2	PSI	Liquid Pressure 2
SATSP	°F	Supply Air Temperature Setpoint	LiqTmp2	°F	Liquid Temperature 2
CoilSP	°F	Coil (Saturation) Temp Setpoint	LACSP	°F	LAC Setpoint
RAT	°F	Return Air Temperature	AlmGrp1	Bit String	Sensor Failure Alarms
RA RH	%	Return Air Humidity	AlmGrp2	Bit String	Mechanical Failure Alarms
OAT	°F	Outdoor Air Temperature	AlmGrp3	Bit String	Failure Mode Alarms
OA RH	%	Outdoor Air Humidity	AlmGrp4	Bit String	Missing Module Alarm
OA WB	°F	Outdoor Air Wetbulb	AlmGrp5	Bit String	Refrigeration Module Alarms
OA DP	°F	Outdoor Air Dew Point	Bin IN	Bit String	Binary inputs Status
ReHeat	%	MHGRV-X Valve Position	Main Rly	Bit String	Relay Status of the VCCX-454-GH Controller
ModGas	%	MODGAS-XWR2 Valve Position	Exp Rly	Bit String	Relay Status of 12 Relay Expansion Module
			1A1Stat	Bit String	Compressor A1 Status

NOTE: For enumerated values, see Table 7 below. For Bit String Values see Table 8, next page.

Table 7: VCCX-454-GH Trend Log Enumerated Values

VCCX-454-GH Trend Log Enumerated Values		
Item	Value	Description
Mode	0	Off
	1	HVAC Active
HVAC	0	Off
	1	Grow Mode
	2	Dry Mode
	3	Fan Mode
	4	Cool Mode
	5	Heat Mode
	6	Purge Mode



Table 8: VCCX-454-GH Trend Log Bit Strings

VCCX-454-GH Trend Log Bit Strings						
Item	Value	Description	Item	Value	Description	
AlmGrp1	1	Bad Supply Sensor	Bin IN	1	Fan Proving	
	2	Bad Return Sensor		2	Dirty Filter	
	4	Bad Outdoor Air Sensor		4	Not Used	
	8	Bad Space Sensor		8	Not Used	
AlmGrp2	1	Not Used		16	Not Used	
	2	Mechanical Heating Alarm		32	Not Used	
	4	Fan Proving Alarm		64	Not Used	
	8	Dirty Filter Alarm		128	Emergency Shutdown	
	16	Emergency Shutdown Alarm	1	Supply Fan Relay #1		
AlmGrp3	1	High Supply Air Temperature Cutoff	MainRly	2	VCCX-454-GH Relay #2 Configurable	
	2	Low Supply Air Temperature Cutoff		4	VCCX2 Relay #3 Configurable	
	4	High Control Temperature Alarm		8	VCCX2 Relay #4 Configurable	
	8	Low Control Temperature Alarm		16	VCCX2 Relay #5 Configurable	
	16	Not Used		32	VCCX2 Relay #6 Configurable	
	32	Not Used		64	VCCX2 Relay #7 Configurable	
	64	High Control Humidity Alarm		128	VCCX2 Relay #8 Configurable	
	128	Low Control Humidity Alarm		1	12 Relay Exp Relay #1 Configurable	
AlmGrp4	1	Missing Refrigeration Module 1	ExpRly	2	12 Relay Exp Relay #2 Configurable	
	2	Missing Refrigeration Module 2		4	12 Relay Exp Relay #3 Configurable	
	4	Missing Refrigeration Module 3		8	12 Relay Exp Relay #4 Configurable	
	8	Missing Refrigeration Module 4		16	12 Relay Exp Relay #5 Configurable	
	16	Not Used		32	12 Relay Exp Relay #6 Configurable	
	32	Missing MHGRV-X Module		64	12 Relay Exp Relay #7 Configurable	
	64	Missing MODGAS-XWR2 Module		128	12 Relay Exp Relay #8 Configurable	
	128	Not Used		256	12 Relay Exp Relay #9 Configurable	
	256	Missing 12 Relay Expansion Module		512	12 Relay Exp Relay #10 Configurable	
	512	Not Used		1024	12 Relay Exp Relay #11 Configurable	
	1024	Not Used		2084	12 Relay Exp Relay #12 Configurable	
	2048	Not Used		1A1Stat	1	System On
	4096	Missing LA Aux Board 1			2	Active Alarm
	8192	Missing LA Aux Board 2			4	Disabled
AlrmGrp5	1	Refrigeration Module #1 Alarm	8		Forced On	
	2	Refrigeration Module #2 Alarm	16		Forced Off	
	4	Refrigeration Module #3 Alarm	32		Outdoor Air Lockout	
	8	Refrigeration Module #4 Alarm	64		System Not Used	
			128		Min Run Pending	
			256		Min Off Pending	
			512		Defrost Mode	

9.5.5. RSMS-GH Trend Logs

There can be as many as four RSMD-GH Modules on a unit, with each controlling up to two compressors and condensers. These can be referred to as modules 1, 2, 3, and 4 or as modules A, B, C, and D. Various items in the trend logs can refer to different modules and different compressors/condensers on each module. For instance:

- 1A1: Stat refers to the status of Module 1/Compressor1
- 4D1 would be Module4/Compressor 1.

Likewise, 1SuctTemp1 refers to the suction (saturation) temperature of Module 1/Compressor1, while 3SucTmp2 refers to the suction (saturation) temperature of Module 3/Compressor 2. Several trend log items use this pattern to identify the status of values related to certain modules and the compressors or condensers on those modules. See Table 9 below for RSMD-GH trend logs.

Table 9: RSMD-GH Module Trend Logs

RSMD-GH Module Trend Log Status Points (Typical of 4 RSM Modules)					
Log Abbreviation	Unit	Item Description	Log Abbreviation	Unit	Item Description
1A1Stat	Bit String	Compressor A1 Status	3C1Stat	Bit String	Compressor C1 Status
1A2Stat	Bit String	Compressor A2 Status	3C2Stat	Bit String	Compressor C2 Status
1Comp1	%	Compressor A1 Modulating Position	3Comp1	%	Compressor C1 Modulating Position
1Comp2	%	Compressor A2 Modulating Position	3Comp2	%	Compressor C2 Modulating Position
1Cond1	%	Condenser A1 Modulating Position	3Cond1	%	Condenser C1 Modulating Position
1Cond2	%	Condenser A2 Modulating Position	3Cond2	%	Condenser C2 Modulating Position
1HeadPr1	PSI	A1 Head Pressure	3HeadPr1	PSI	C1 Head Pressure
1HeadPr2	PSI	A2 Head Pressure	3HeadPr2	PSI	C2 Head Pressure
1SuctPr1	PSI	A1 Suction Pressure	3SucPr1	PSI	C1 Suction Pressure
1SuctPr2	PSI	A2 Suction Pressure	3SucPr2	PSI	C2 Suction Pressure
1SuctTmp1	°F	A1 Saturation Temperature	3SucTmp1	°F	C1 Saturation Temperature
1SuctTmp2	°F	A2 Saturation Temperature	3SucTmp2	°F	C2 Saturation Temperature
1CoilSP	°F	RSMD 1 Saturation (Suction) Setpoint	3CoilSP	°F	RSMD 3 Saturation (Suction) Setpoint
1DisChg1	°F	A1 Discharge Temperature	3DisChg1	°F	C1 Discharge Temperature
1DisChg2	°F	A2 Discharge Temperature	3DisChg2	°F	C2 Discharge Temperature
1Relays1	Bit String	RSMD 1 Relay Status	3Relays3	Bit String	RSMD 3 Relay Status
2B1Stat	Bit String	Compressor B1 Status	4D1Stat	Bit String	Compressor D1 Status
2B2Stat	Bit String	Compressor B2 Status	4D2Stat	Bit String	Compressor D2 Status
2Comp1	%	Compressor B1 Modulating Position	4Comp1	%	Compressor D1 Modulating Position
2Comp2	%	Compressor B2 Modulating Position	4Comp2	%	Compressor D2 Modulating Position
2Cond1	%	Condenser B1 Modulating Position	4Cond1	%	Condenser D1 Modulating Position
2Cond2	%	Condenser B2 Modulating Position	4Cond2	%	Condenser D2 Modulating Position
2HeadPr1	PSI	B1 Head Pressure	4HeadPr1	PSI	D1 Head Pressure



RSMD-GH Module Trend Log Status Points (Typical of 4 RSM Modules)					
Log Abbreviation	Unit	Item Description	Log Abbreviation	Unit	Item Description
2HeadPr2	PSI	B2 Head Pressure	4HeadPr2	PSI	D2 Head Pressure
2SucPr1	PSI	B1 Suction Pressure	4SucPr1	PSI	D1 Suction Pressure
2SucPr2	PSI	B2 Suction Pressure	4SucPr2	PSI	D2 Suction Pressure
2SucTmp1	°F	B1 Saturation Temperature	4SucTmp1	°F	D1 Saturation Temperature
2SucTmp2	°F	B2 Saturation Temperature	4SucTmp2	°F	D2 Saturation Temperature
2CoilSP	°F	RSMD 2 Saturation (Suction) Setpoint	4CoilSP	°F	RSMD 4 Saturation (Suction) Setpoint
2DisChg1	°F	B1 Discharge Temperature	4DisChg1	°F	D1 Discharge Temperature
2DisChg2	°F	B2 Discharge Temperature	4DisChg2	°F	D2 Discharge Temperature
2Relays2	Bit String	RSMD 2 Relay Status	4Relays4	Bit String	RSMD 4 Relay Status

Table 10: RSMD-GH Trend Log Bit Strings

RSMD-GH Trend Log Bit Strings		
Item	Value	Description
1Relays1 2Relays2 3Relays3 4Relays4	1	1st Relay
	2	2nd Relay
	4	3rd Relay
	8	4th Relay
	16	5th Relay
	32	Unloader 1
	64	Unloader 2
1A1Stat 1A2Stat 2B1Stat 2B2Stat 3C1Stat 3C2Stat 4D1Stat 4D2Stat	1	System On
	2	Active Alarm
	4	Disabled
	8	Forced On
	16	Forced Off
	32	Outdoor Air Lockout
	64	System Not Used
	128	Min Run Pending
	256	Min Off Pending
512	Defrost Mode	

10. TROUBLESHOOTING

10.1. VCCX-454-GH Controller and RSM LED Diagnostics

10.1.1. VCCX-454-GH Controller LEDs

The VCCX-454-GH Controller is equipped with LEDs that can be used to verify operation and perform troubleshooting. There are LEDs for communication, operation modes, and diagnostic codes. The VCCX-454-GH Controller has 26 LEDs-10 used for operation and status, eight are used for relays, and eight are used for binary inputs. See Figure 30, page 67, for the LED locations. The LEDs associated with these inputs and outputs show what is active without using a voltmeter. The LEDs and their uses are as follows:

Operation LEDs – Factory Troubleshooting

POWER

This green LED lights up to indicate that 24 VAC power has been applied to the controller.

APP HB

This green LED lights up and blinks continuously to indicate the application software is working properly.

OS BH

This green LED lights up and blinks continuously to indicate the operating system is working properly.

WDOG

This green LED lights up and stays lit to indicate the operating system is working properly.

Diagnostic LEDs

ALARM

This red LED is a diagnostic blink code LED. It lights up and stays lit when there is an alarm present. The type of alarm is shown on the LCD display.

STATUS 1

This red LED is a diagnostic blink code LED. Under normal operation, it should not be blinking. If the LED is blinking non-stop along with the Status 2 LED, the controller is resetting to factory defaults.

STATUS 2

This red LED is a diagnostic blink code LED. If the software is running, this LED should blink at a rate of one blink every 10 seconds. If there is an override, the LED blinks two times every 10 seconds. And finally, if one of the outputs is in Force Mode, the LED blinks three times every 10 seconds.

Communication LEDs

EBUS

This yellow LED blinks to signal E-BUS communications.

LOOP COMM

This yellow LED lights up and blinks continuously to indicate the VCCX-454-GH Controller is communicating.

BACnet

This yellow LED lights up and blinks continuously to indicate BACnet communications.



VCCX-454-GH Controller LEDs (Controlled)

Relay LEDs

RLY1

This green LED lights up when the supply fan is enabled and stays lit as long as the supply fan is active.

RLY2-RLY8

These green LEDs light up when the relays are enabled and stays lit as long as they are active.

Binary Input LEDs

BI1

This green LED lights up when the proof of flow contact is closed.

BI2

This green LED lights up when the dirty filter switch is closed.

BI8

This green LED lights up when the emergency shutdown contact is closed.

NOTE: Unless there is a wiring error, BI3 through BI7 are not used.

10.1.2. RSMD LEDs

The RSM LEDs are described in the RSM Technical Guides.

10.2.VCCX-454 Controller LED Diagnostics

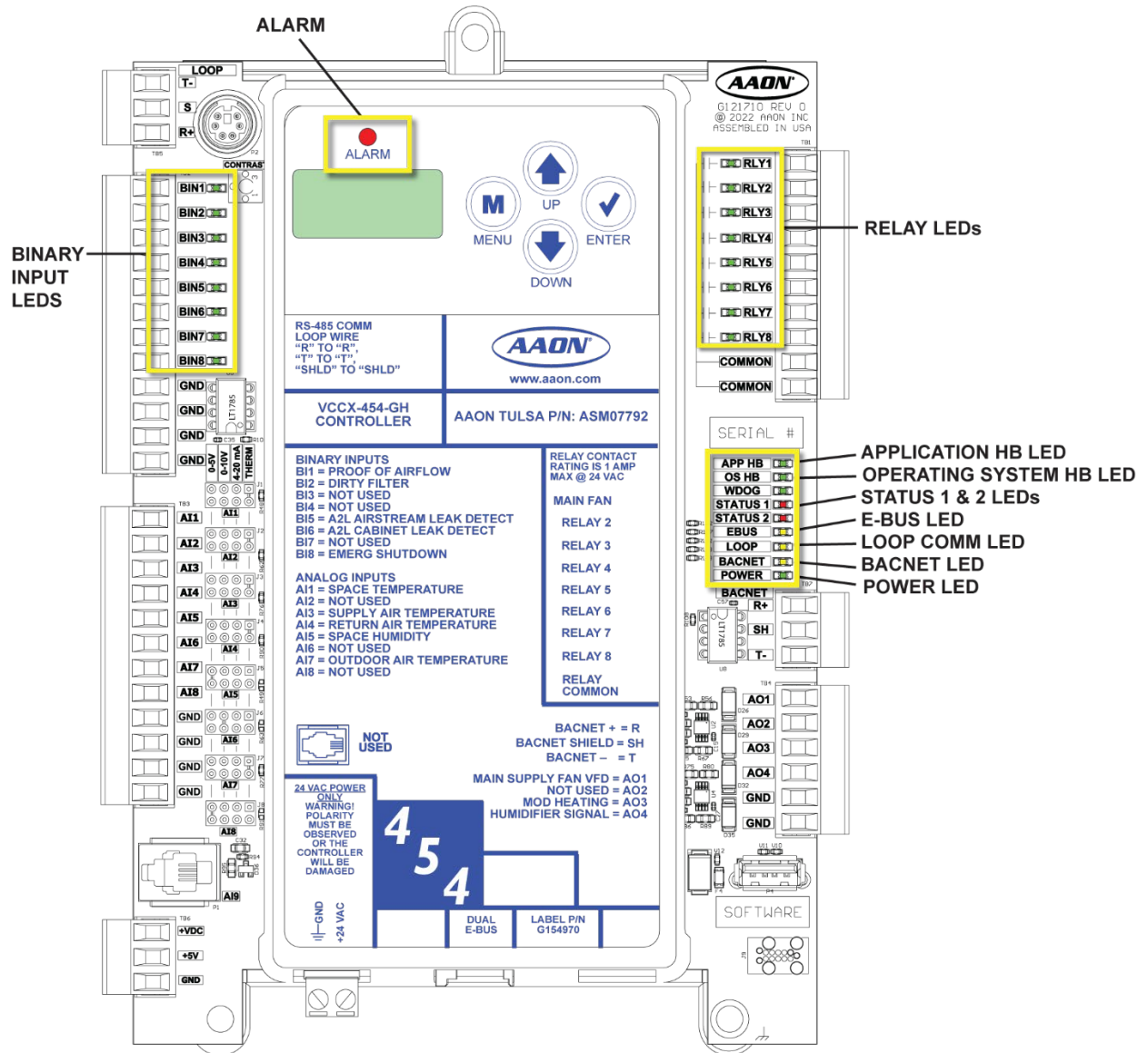

Figure 30: VCCX-454-GH Controller LED Locations

10.3. Temperature Sensor Testing

10.3.1. Space, Supply Air, Outdoor Air, or Return Air Temperature Sensor Testing

The following sensor voltage and resistance table is provided to aid in checking sensors that appear to be operating incorrectly. Many system operating problems can be traced to incorrect sensor wiring. Be sure all sensors are wired per the wiring diagrams in this manual.

If the sensors still do not appear to be operating or reading correctly, check voltage and/or resistance to confirm the sensor is operating correctly per the tables. Please follow the notes and instructions that appear after the chart when checking sensors.

10.3.2. Thermistor Sensor Testing Instructions

Use the resistance column to check the Thermistor sensor while disconnected from the controllers (not powered).

Use the voltage column to check sensors while connected to powered controllers. Read the voltage with the meter set on DC volts. Place the "-" (minus) lead on the GND terminal and the "+" (plus) lead on the sensor input terminal being investigated.

Table 11: 0-5V Temperature Sensor – Voltage and Resistor Type for Type III 10 K OHM Thermistor Sensors

Temperature – Resistance – Voltage for Type III 10 K OHM Thermistor Sensors							
Temp (°F)	Temp (°C)	Resistance (Ohms)	Voltage @ Input (VDC)	Temp (°F)	Temp (°C)	Resistance (Ohms)	Voltage @ Input (VDC)
-10	-23.3	93333	4.51	72	22.2	11136	2.635
-5	-20.6	80531	4.45	73	22.8	10878	2.605
0	-17.8	69822	4.37	74	23.3	10625	2.576
5	-15	60552	4.29	75	23.9	10398	2.549
10	-12.2	52500	4.2	76	24.4	10158	2.52
15	-9.4	45902	4.1	77	25	10000	2.5
20	-6.6	40147	4.002	78	25.6	9711	2.464
25	-3.9	35165	3.891	80	26.7	9302	2.41
30	-1.1	30805	3.773	82	27.8	8893	2.354
35	1.7	27140	3.651	84	28.9	8514	2.3
40	4 4.4	23874	3.522	86	30	8153	2.246
45	7.2	21094	3.39	88	31.1	7805	2.192
50	10	18655	3.252	90	32.2	7472	2.139
52	11.1	17799	3.199	95	35	6716	2.009
54	12.2	16956	3.143	100	37.8	6047	1.884
56	13.3	16164	3.087	105	40.6	5453	1.765
58	14.4	15385	3.029	110	43.3	4923	1.65
60	15.6	14681	2.972	115	46.1	4449	1.54
62	16.7	14014	2.916	120	48.9	4030	1.436
64	17.8	13382	2.861	125	51.7	3656	1.339
66	18.9	12758	2.802	130	54.4	3317	1.246
68	20	12191	2.746	135	57.2	3015	1.159
69	20.6	11906	2.717	140	60	2743	1.077
70	21.1	11652	2.691	145	62.7	2502	1.001
71	21.7	11379	2.661	150	65.6	2288	0.931

NOTE: If the voltage is above 4.88 VDC, then the sensor or wiring is "open." If the voltage is less than 0.05 VDC, then the sensor or wiring is shorted.

11. APPENDIX A - SYSTEM CONFIGURATION

11.1. System Configurations

11.1.1. System Configuration Options

The VCCX-454-GH Controller can be used as a stand-alone system (one VCCX-454-GH Controller only), connected together on an interconnected system (multiple VCCX-454-GH Controllers only), or connected together on a network system (multiple VCCX-454-GH Controllers or add-on controllers) to form a complete controls system that can be programmed and monitored with one or more of the available operator interfaces.

Operator Interfaces

Operator interfaces are designed to provide for programming and monitoring of VCCX-454-GH Controller(s) or add-on controller(s) connected to the system. Set-up, configuration, and monitoring of the VCCX-454-GH Controller can only be accomplished using the Prism 2 front-end software on a personal computer.

Stand-Alone System

The stand-alone system is used with a single VCCX-454-GH Controller Programming.

Interconnected System

The interconnected system is used when there are multiple VCCX-454_GH Controllers. With this system, connect the controllers together using AAON communications wire or 18-gauge, two-conductor, twisted pair with shield wire (Belden #82760 or equivalent). This allows all controllers that are connected to the communications loop to be programmed and monitored from Prism 2 connected to the communications loop.

Networked System

For a networked single loop system, a range of one to 59 VCCX-454-GH Controllers sharing information, connect the controllers together using AAON communications wire or 18-gauge, two-conductor, twisted pair with shield wire (Belden #82760 or equivalent). The networked single loop system requires either a MiniLink PD communication interface and/or CommLink communication interface to be purchased and wired into the communications loop to the VCCX-454-GH Controllers.

The networked multiple loop system is used for a system with more than 59 VCCX-454-GH Controllers. These groups of controllers are broken into multiple "local loops" that connect to each other via the "network loop". Each MiniLink PD handles its specific local loop's communication requirements. The CommLink Communications interface handles all the communications between the individual MiniLink PDs to form the network loop. Up to 60 local loops can be connected with this configuration. This provides the capability for more than 3,500 controllers to be networked.

12. APPENDIX B - VCCX-454-GH LCD SCREENS

12.1. Navigation Keys

12.1.1. LCD Display Screen and Navigation Keys

The LCD display screens and buttons allow display status and alarms, enable force modes, and make BACnet configuration changes. See Figure 31 and Table 12 below for Navigation Key functions. The keys also have editing functions. Refer to Table 13, on the right, for editing functions.

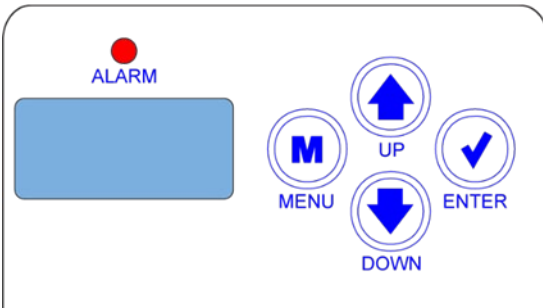

Figure 31: LCD Display and Navigation Keys

Table 12: Navigation Key Functions

Navigation Key Functions	
Key	Function
MENU 	Use the <MENU> key to move through screens within Main Menu categories and return to the Main Menu while at other screens.
UP 	Use this key to adjust setpoints and change configurations.
DOWN 	Use this key to adjust setpoints and change configurations.
ENTER 	Use the <ENTER> key to navigate through the Main Menu Screen categories.

Table 13: Editing Key Functions

Navigation Key Functions	
Key	Function
UP or DOWN 	Use the <UP> or <DOWN> key to enter Edit Mode on a user-adjustable screen. Edit Mode is indicated by the underscore appearing on the screen. NOTE: Entering Edit Mode will also adjust the value up one (<UP> key) or down one (<DOWN> key), so you may have to readjust the value.
ENTER 	Use the <ENTER> key to move through the digits on the screen when editing a numeric value. An extended press of the <ENTER> key saves your edits, no matter the location of the editing cursor within the digits. Press the <ENTER> key to save a non-numeric value such as Hi Speed Network.
MENU 	The <MENU> key cancels editing when in Edit Mode. The screen you were editing will return to its original value, and the underscore will disappear. A second press of the <MENU> key will return you to the Main Menu.

12.2. Main Screens Map

12.2.1. Main Screens Map

Refer to the following map when navigating through the Main screens. The first screen is an initialization screen. To scroll through the rest of the screens, press the <MENU> button.

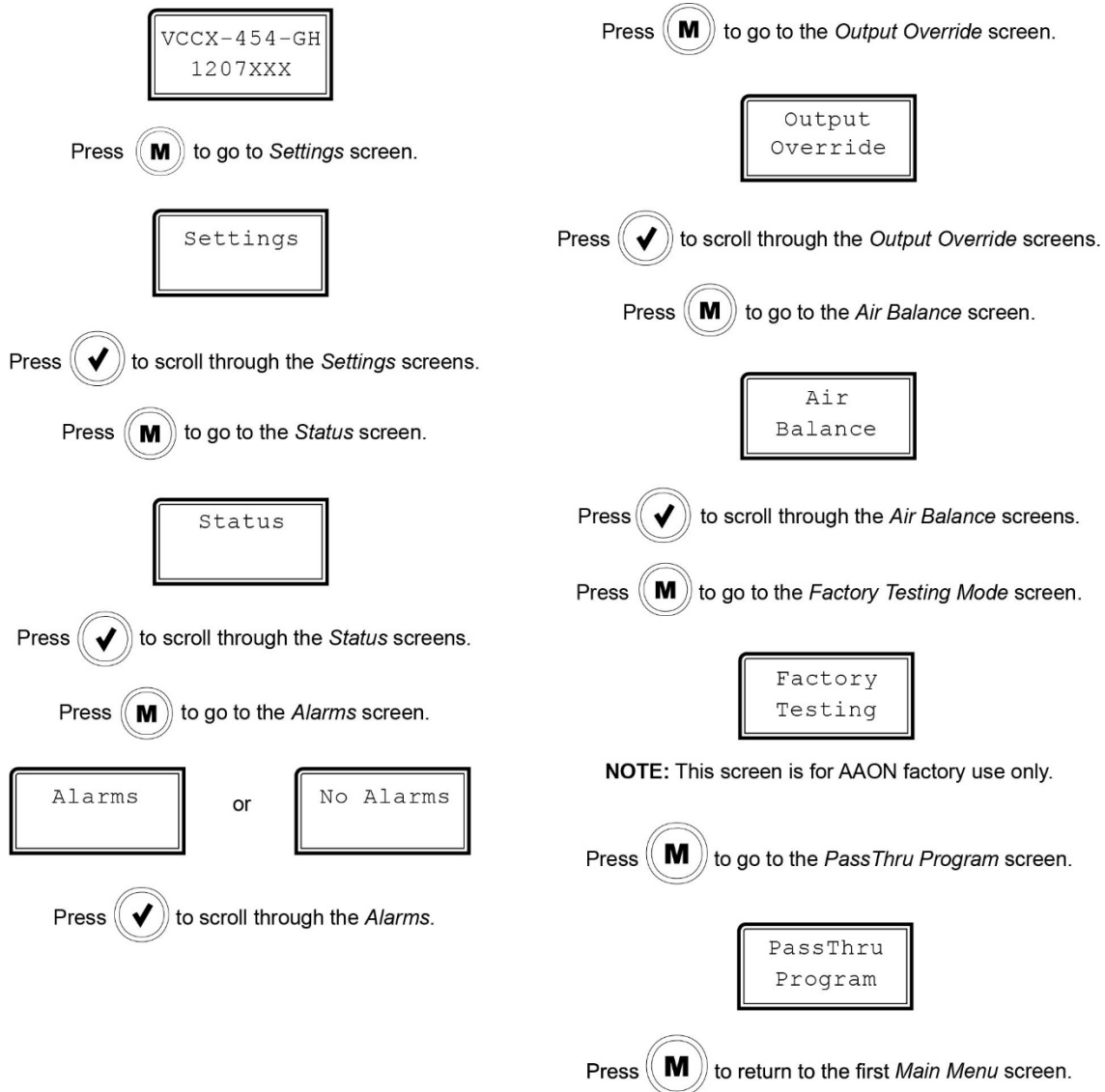

Figure 32: VCCX-454-GH Main Screens Map

12.3. Setting Screens

12.3.1. Settings Screens

Refer to the following map when navigating through the Settings screens. From the Settings screen, press **<ENTER>** to scroll through the screens.

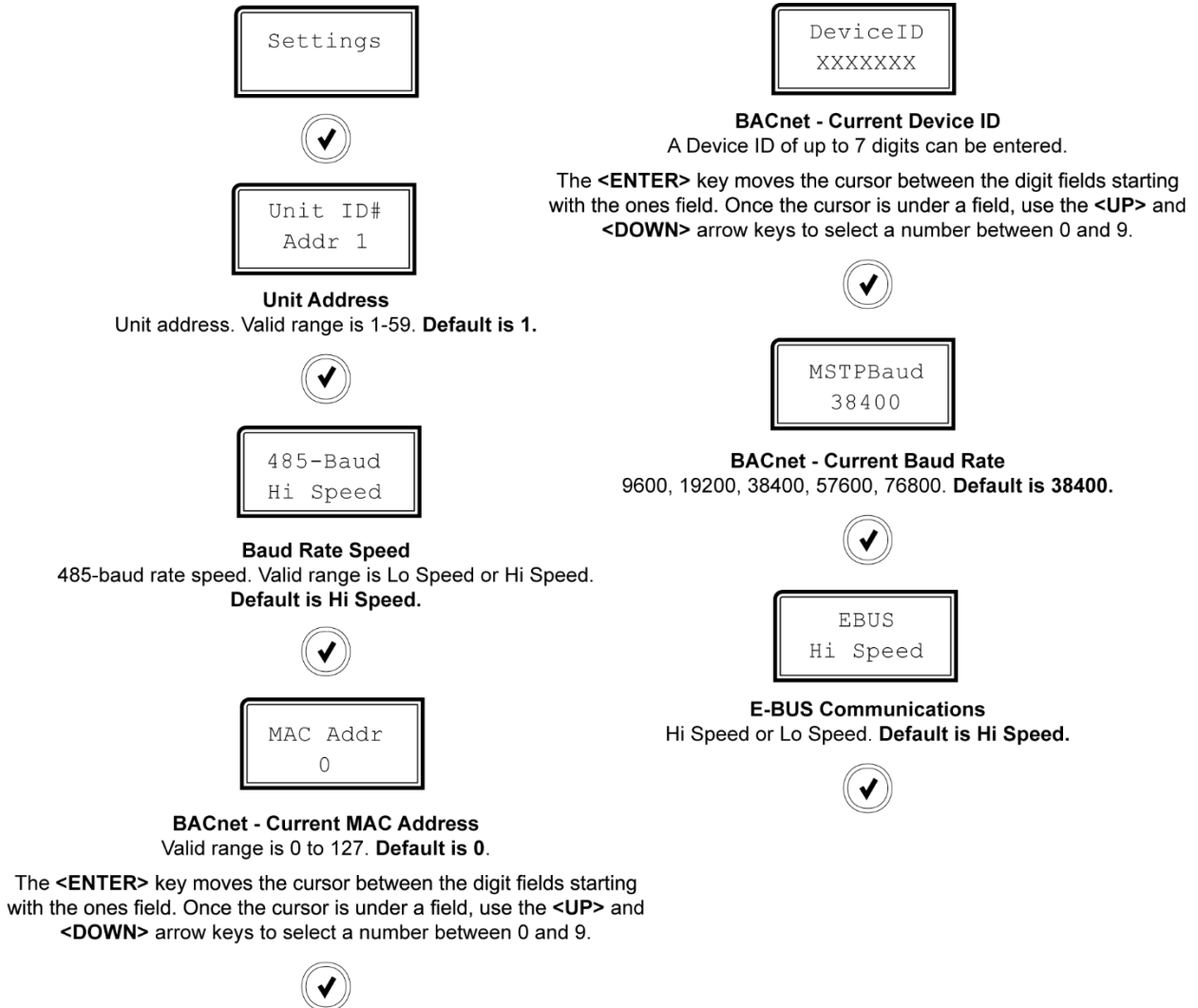

Figure 33: VCCX-454-GH Setting Screens

12.4. Status Screens

12.4.1. Status Screens

Refer to the following map when navigating through the Status screens. From the Status Screen, press <ENTER> to scroll through the screens.

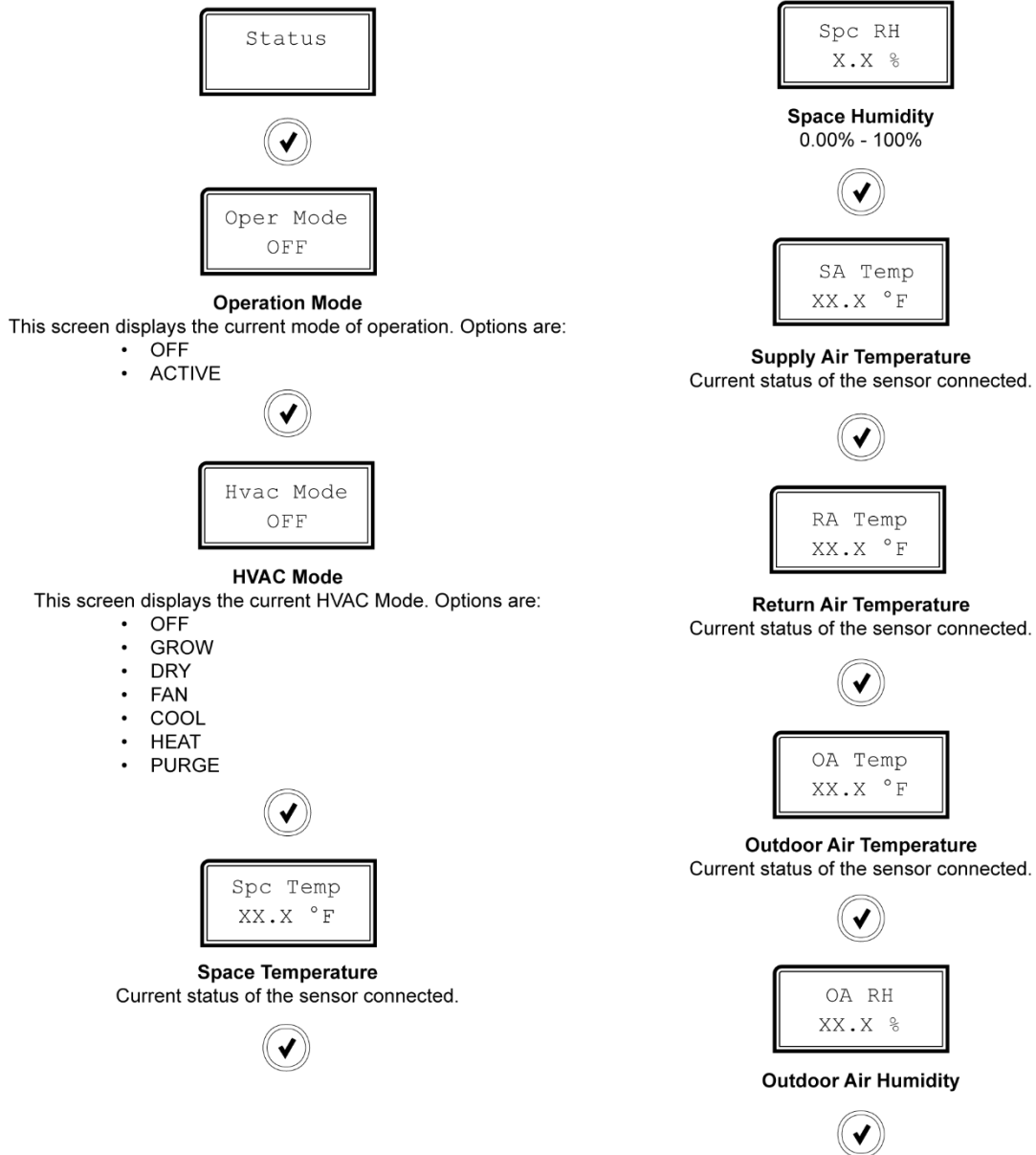

Figure 34: VCCX-454-GH Status Screens

12.5. Alarm Screens

12.5.1. Alarm Screens

If there are no Alarms, the Alarm screen will display "No Alarms." If there are alarms present, the screen will display "Alarms." Press <**ENTER**> to scroll through the alarms or let the alarms automatically scroll on the screen.

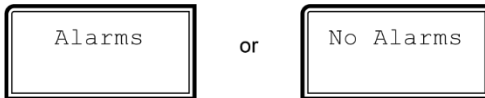

Figure 35: VCCX-454-GH Alarm Screens

Table 14: Alarm Screens

Alarm Screens	
Alarm	Description
No Alarms	No alarms are present
SAT Sensor	Supply Air Temperature Sensor failure alarm
RAT Sensor	Return Air Temperature Sensor failure alarm
OAT Sensor	Outdoor Air Temperature Sensor failure alarm
SPC 1 Sensor	Space Temperature Sensor 1 failure alarm
SPC 2 Sensor	Space Temperature Sensor 2 failure alarm
SPC 3 Sensor	Space Temperature Sensor 3 failure alarm
SPC 4 Sensor	Space Temperature Sensor 4 failure alarm
SPC 5 Sensor	Space Temperature Sensor 5 failure alarm
SPC 6 Sensor	Space Temperature Sensor 6 failure alarm
SPC 7 Sensor	Space Temperature Sensor 7 failure alarm
SPC 8 Sensor	Space Temperature Sensor 8 failure alarm
SPC 9 Sensor	Space Temperature Sensor 9 failure alarm
SPC 10 Sensor	Space Temperature Sensor 10 failure alarm
SPC Alarm	Space Temperature alarm
SPC Missing	Space Temperature missing
Heating Failure	Mechanical heating failure alarm
Fan POF Failure	Proof of flow interlock alarm
Dirty Filter	Dirty filter alarm
Emerg Shutdown	Emergency shutdown alarm
HI SAT Alarm	High supply temperature cutoff alarm
LO SAT Alarm	Low supply temperature cutoff alarm
Control Temp HI	High control temperature failure
Control Temp LO	Low control temperature failure
Control RH HI	High control humidity failure
Control RH LO	Low control humidity failure
Refrig 1 Missing	Refrigerant board 1 missing alarm
Refrig 2 Missing	Refrigerant board 2 missing alarm
Refrig 3 Missing	Refrigerant board 3 missing alarm
Refrig 4 Missing	Refrigerant board 4 missing alarm
Rheat Alarm	Reheat board missing alarm
Modgas Alarm	MODGAS-XWR2 board missing alarm
12 Relay Alarm	Missing E-BUS 12 Relay Module alarm
LAC1 Missing	LAC1 board missing alarm
LAC2 Missing	LAC2 board missing alarm
Module 1 Alarm	Refrigerant Module #1 operating alarm
Module 2 Alarm	Refrigerant Module #2 operating alarm
Module 3 Alarm	Refrigerant Module #3 operating alarm
Module 4 Alarm	Refrigerant Module #4 operating alarm
Unknown Alarm	An alarm is generated, but the controller does not understand it.

12.6. Output Override Screens

12.6.1. Output Override Screens

Refer to the following map when navigating through the Output Override screens. From the Output Override screen, press **<ENTER>**.

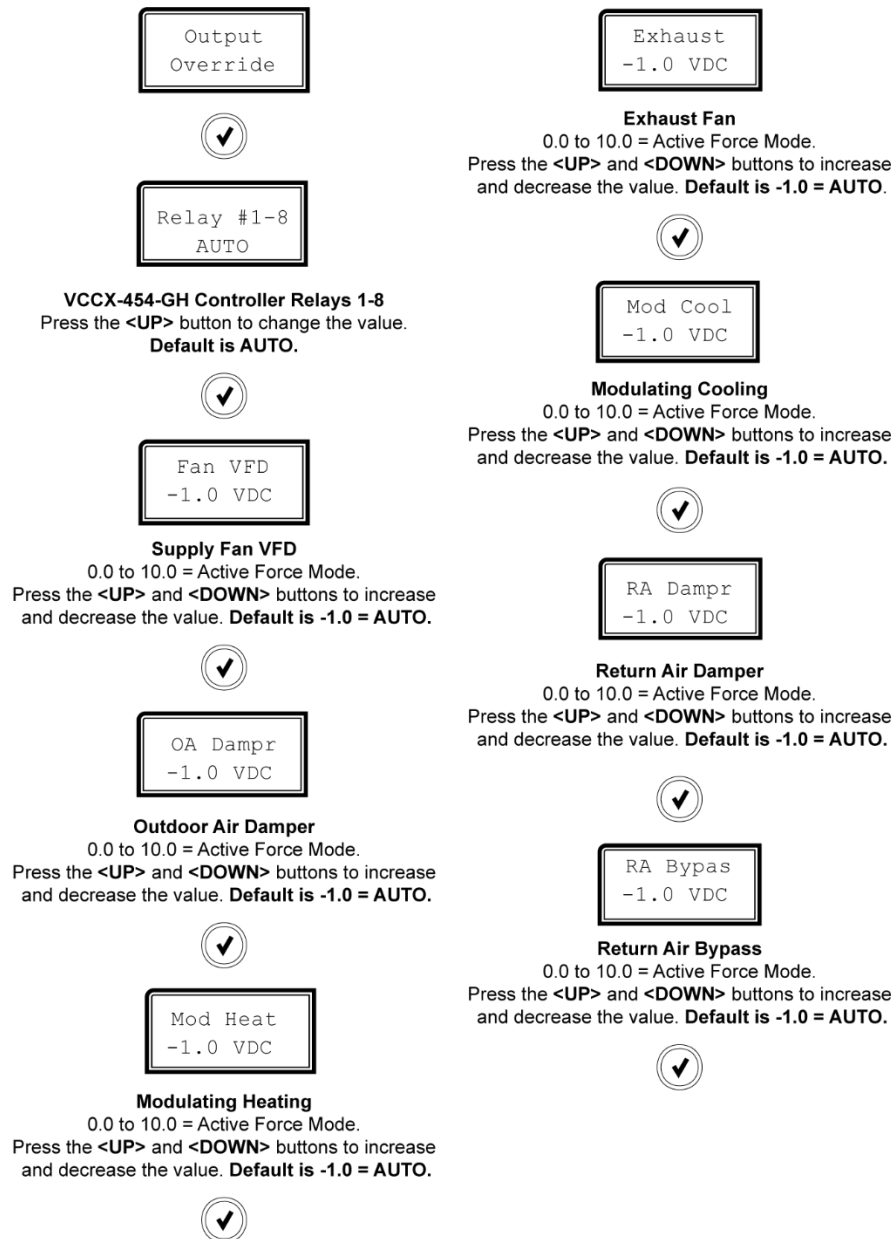

Figure 36: VCCX-454-GH Output Override Screens

12.7. Air Balance Screens

12.7.1. Air Balance Screens

Refer to the following map when navigating through the Air Balance screens. From the Air Balance screen, press **<ENTER>**.

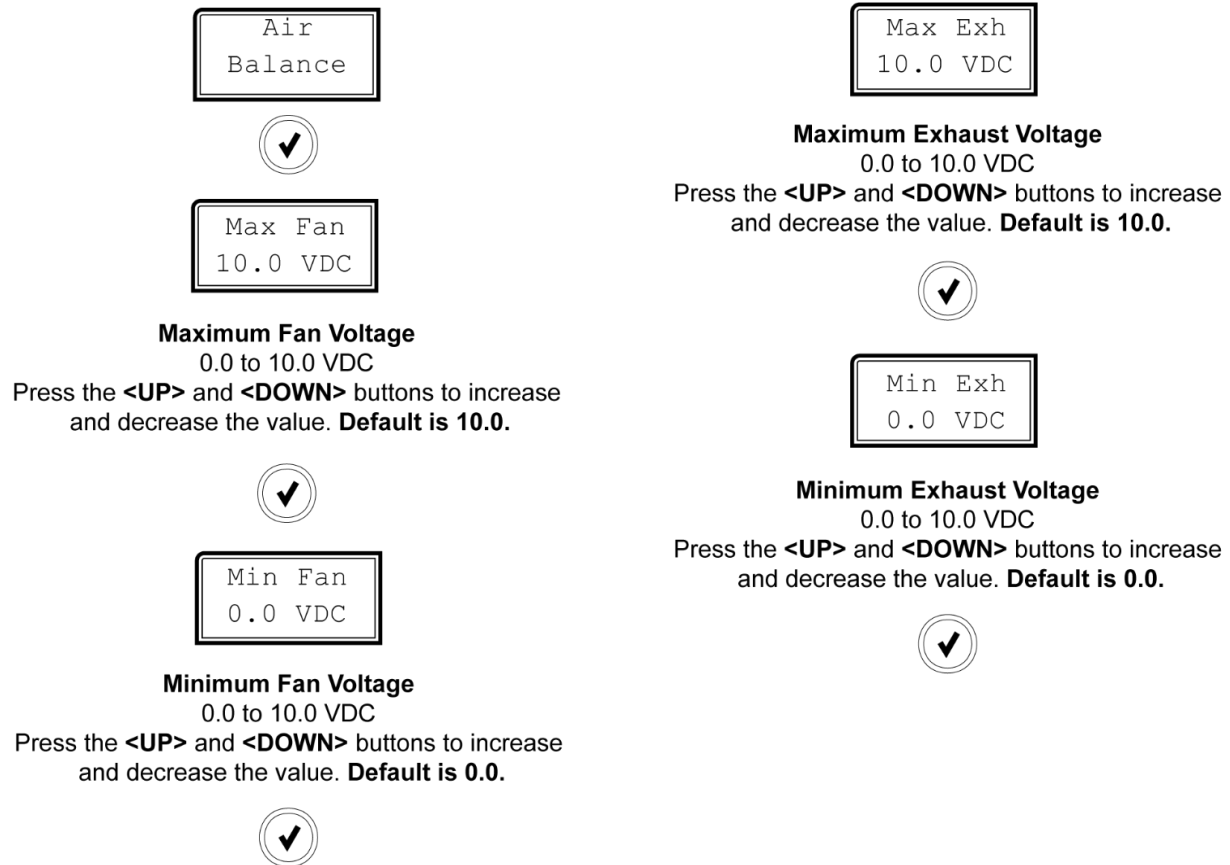

Figure 37: VCCX-454-GH Air Balance Screens

13. APPENDIX C - VCCX-454-GH BACNET

13.1. VCCX-454-GH BACnet Connection to MS/TP Network

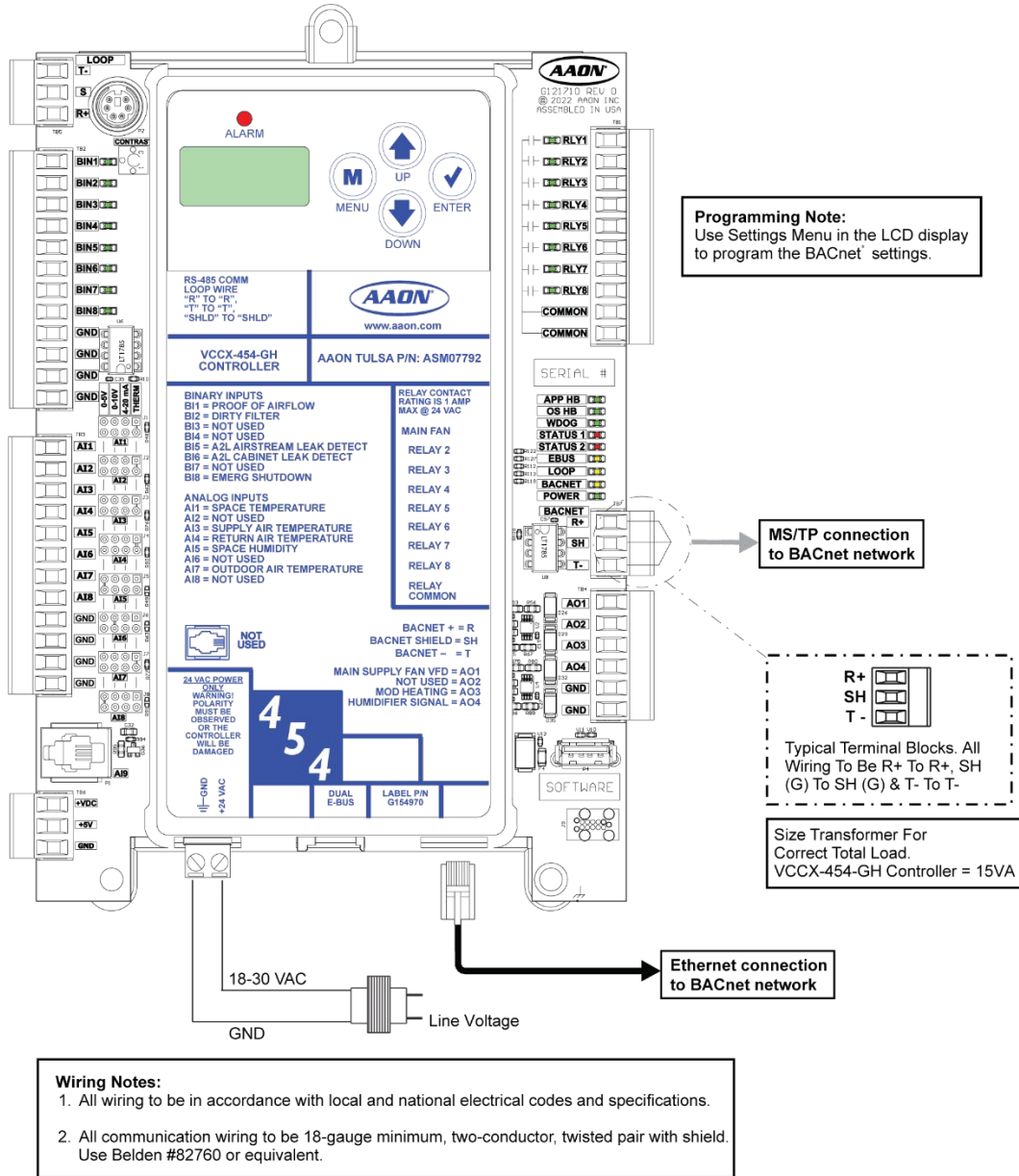

Figure 38: VCCX-454-GH BACnet Connection to MS/TP Network

13.2. BACnet Connection to MS/TP or IP Network

⚠ CAUTION

Please ensure the wiring complies with ASHRAE BACnet standards.

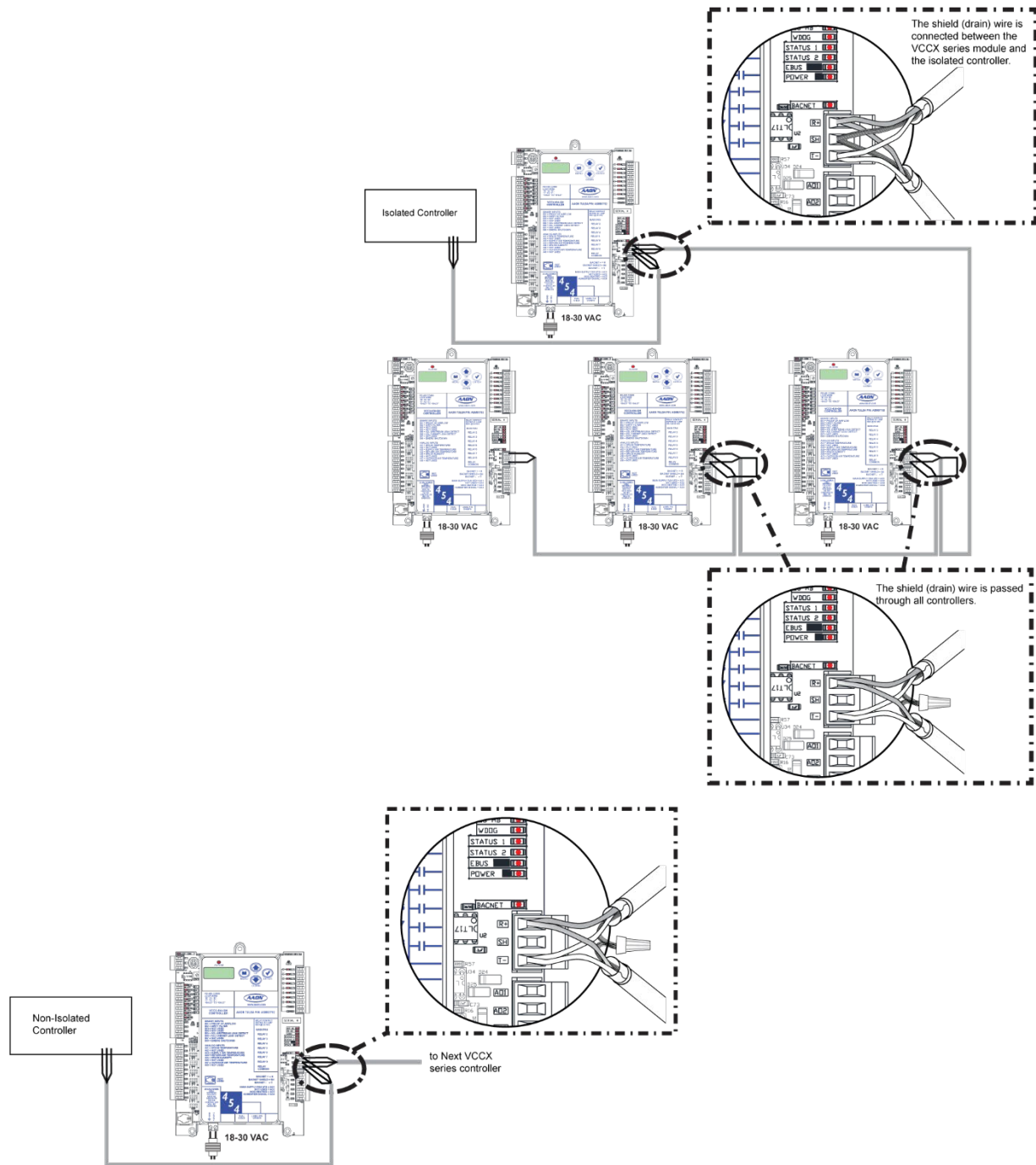

Figure 39: Wiring Example - Shield (Drain) Wiring for Isolated and Non-Isolated Connections

13.3.VCCX-454-GH BACnet Analog Parameters

Table 15: VCCX-454-GH Analog Inputs

BACnet Properties for the VCCX-454-GH Controller Analog Inputs		
Parameter	Object	Description
Application Software Version	AI: 1	Current version of the software in the unit.
Space Temperature	AI: 2	Current value of the Space Temperature Sensor.
Space Humidity	AI: 3	Current value of the space humidity.
Space Dew Point	AI: 4	Current calculated space dew point.
Target Space Dew Point	AI: 5	Current Space Dew point the unit is controlling to in Grow Mode.
Supply Air Temperature	AI: 6	Current value of the Supply Air Temperature Sensor.
Outdoor Air Temperature	AI: 7	Current value of the Outdoor Air Temperature Sensor.
Modulating Heat Position	AI: 8	Current percentage of the modulating heating signal (hot water or SCR heat).
Mod Hot Gas Reheat Valve Position	AI: 9	Current position of MHGRV Modulating Hot Gas Reheat Valve.
Main Fan Control Signal	AI: 10	Current control signal is being sent to the supply fan VFD.
Space Sensor 1 Temp	AI: 11	Current temperature reading from digital Space Sensor #1.
Space Sensor 1 Hum	AI: 12	Current humidity reading from digital Space Sensor #1.
Space Sensor 2 Temp	AI: 13	Current temperature reading from digital Space Sensor #2.
Space Sensor 2 Hum	AI: 14	Current humidity reading from digital Space Sensor #2.
Space Sensor 3 Temp	AI: 15	Current temperature reading from digital Space Sensor #3.
Space Sensor 3 Hum	AI: 16	Current humidity reading from digital Space Sensor #3.
Space Sensor 4 Temp	AI: 17	Current temperature reading from digital Space Sensor #4.
Space Sensor 4 Hum	AI: 18	Current humidity reading from digital Space Sensor #4.
Space Sensor 5 Temp	AI: 19	Current temperature reading from digital Space Sensor #5.
Space Sensor 5 Hum	AI: 20	Current humidity reading from digital Space Sensor #5.
Space Sensor 6 Temp	AI: 21	Current temperature reading from digital Space Sensor #6.
Space Sensor 6 Hum	AI: 22	Current humidity reading from digital Space Sensor #6.
Space Sensor 7 Temp	AI: 23	Current temperature reading from digital Space Sensor #7.
Space Sensor 7 Hum	AI: 24	Current humidity reading from digital Space Sensor #7.
Space Sensor 8 Temp	AI: 25	Current temperature reading from digital Space Sensor #8.
Space Sensor 8 Hum	AI: 26	Current humidity reading from digital Space Sensor #8.
Space Sensor 9 Temp	AI: 27	Current temperature reading from digital Space Sensor #9.
Space Sensor 9 Hum	AI: 28	Current humidity reading from digital Space Sensor #9.
Space Sensor 10 Temp	AI: 29	Current temperature reading from digital Space Sensor #10.
Space Sensor 10 Hum	AI: 30	Current humidity reading from digital Space Sensor #10.
Humidifier Output	AI: 31	Current value of the signal going to the humidifier.
A1 Compressor Signal	AI:50	Current Compressor A1 modulating cooling signal.
A Condenser Signal	AI:51	Current A Condenser signal.
A Suction Pressure	AI:52	Current Compressor A suction pressure.
A Head Pressure	AI:53	Current Compressor A head pressure.
A Saturation Temperature	AI:54	Current Compressor A Coil Saturation Temperature.
B1 Compressor Signal	AI:60	Current Compressor B1 modulating cooling signal.
B Condenser Signal	AI:61	Current B Condenser signal.
B Suction Pressure	AI:62	Current Compressor B suction pressure.
B Head Pressure	AI:63	Current Compressor B head pressure.



BACnet Properties for the VCCX-454-GH Controller Analog Inputs		
Parameter	Object	Description
B Saturation Temperature	AI:64	Current Compressor B Coil Saturation Temperature.
C1 Compressor Signal	AI: 70	Current Compressor C1 modulating cooling signal.
C Condenser Signal	AI: 71	Current C Condenser signal.
C Suction Pressure	AI: 72	Current Compressor C suction pressure.
C Head Pressure	AI: 73	Current Compressor C head pressure.
C Saturation Temperature	AI: 74	Current Compressor C Coil Saturation Temperature.
D1 Compressor Signal	AI: 80	Current Compressor D1 modulating cooling signal.
D Condenser Signal	AI: 81	Current D Condenser signal.
D Suction Pressure	AI: 82	Current Compressor D suction pressure.
D Head Pressure	AI: 83	Current Compressor D head pressure.
D Saturation Temperature	AI: 84	Current Compressor D Coil Saturation Temperature.
Mod Gas Heat Valve Position	AI: 90	Current position of MODGAS-XWR2 Valve Control.
Mod Gas Active Stages	AI: 91	Current number of gas heat stages active.

NOTE: Objects labeled AI are read-only.



Table 16: VCCX-454-Analog Values

BACnet Properties for the VCCX-454-GH Controller Analog Values				
Parameter	Object	Description	Limits	
			Low	High
Space Temperature Setpoint	AV: 1	This is the space temperature the controller is trying to control.	1°F	110°F
Space RH Setpoint	AV: 2	This is the space humidity the controller is trying to control.	0%	100%
Reference Space Temperature	AV: 3	If the controller is configured to use a space temperature from BACnet, this is the value it will use.	0°F	120°F
Reference Space RH	AV: 4	If the controller is configured to use a space humidity from BACnet, this is the value it will use.	0%	100%
Humidity Control Output	AV: 5	If a humidifier is being controlled via BACnet, this is the output signal that will be sent to it.	0 V	10 V
Supply Fan Override	AV: 6	Override to force the VFD to this percentage speed. Configuring "Auto" will restore normal unit control of the VFD speed.	0%	100%
BACnet Alive Toggle	AV: 7	When the controller is configured to use BACnet space temperature and humidity readings, this value must be toggled for the controller to continue using the values sent to it. If this value doesn't change for two minutes, the controller will start using readings from sensors connected to the controller if configured to do so or generate a Space Sensor failure alarm.	0	1

NOTE: Objects labeled AV are read/write. The only sensor values that can be written are AV points 3 and 4.

Table 17: VCCX-454-GH Binary Inputs

BACnet Properties for the VCCX-454-GH Controller Binary Inputs		
Parameter	Object	Description
Drying Mode Defrost Active	BI: 1	Indicates that a evaporative coil defrost is occurring.
Main Fan Relay Status	BI: 2	Current status of Main Fan Relay #1 on main board.
Relay #2 Status	BI: 3	Current status of Configurable Relay #2 on main board.
Relay #3 Status	BI: 4	Current status of Configurable Relay #3 on main board.
Relay #4 Status	BI: 5	Current status of Configurable Relay #4 on main board.
Relay #5 Status	BI: 6	Current status of Configurable Relay #5 on main board.
Relay #6 Status	BI: 7	Current status of Configurable Relay #6 on main board.
Relay #7 Status	BI: 8	Current status of Configurable Relay #7 on main board.
Relay #8 Status	BI: 9	Current status of Configurable Relay #8 on main board.
Expansion Relay #1 Status	BI: 10	Current status of Configurable Relay #1 on 12 relay board.
Expansion Relay #2 Status	BI: 11	Current status of Configurable Relay #2 on 12 relay board.
Expansion Relay #3 Status	BI: 12	Current status of Configurable Relay #3 on 12 relay board.
Expansion Relay #4 Status	BI: 13	Current status of Configurable Relay #4 on 12 relay board.
Expansion Relay #5 Status	BI: 14	Current status of Configurable Relay #5 on 12 relay board.
Expansion Relay #6 Status	BI: 15	Current status of Configurable Relay #6 on 12 relay board.
Expansion Relay #7 Status	BI: 16	Current status of Configurable Relay #7 on 12 relay board.
Expansion Relay #8 Status	BI: 17	Current status of Configurable Relay #8 on 12 relay board.
Expansion Relay #9 Status	BI: 18	Current status of Configurable Relay #9 on 12 relay board.
Expansion Relay #10 Status	BI: 19	Current status of Configurable Relay #10 on 12 relay board.
Expansion Relay #11 Status	BI: 20	Current status of Configurable Relay #11 on 12 relay board.
Expansion Relay #12 Status	BI: 21	Current status of Configurable Relay #12 on 12 relay board.
Reheat Enable	BI: 22	Current enable status of MHGRV-X series module.
LA Control Enable	BI: 23	Current enable status of LA Auxiliary module.
Modgas Enable	BI: 24	Current enable status of MODGAS-XWR2 series module.
Humidifier Forced Deactivated	BI: 30	The humidifier relay is normally driven via BACnet commands. A value of 1 indicates this output is forced inactive due to an alarm condition, such as an emergency shutdown.
CO2 Forced Deactivated	BI: 31	The CO ₂ relay is normally driven via BACnet commands. A value of 1 indicates this output is forced inactive due to an alarm condition, such as an emergency shutdown.
Supply Air Sensor Failure	BI: 32	This alarm indicates a failure of the Supply Air Sensor.
Space Sensor 1 Failure	BI: 33	This alarm indicates that the digital Space Sensor #1 is not communicating with the main controller.
Space Sensor 2 Failure	BI: 34	This alarm indicates that the digital Space Sensor #2 is not communicating with the main controller.
Space Sensor 3 Failure	BI: 35	This alarm indicates that the digital Space Sensor #3 is not communicating with the main controller.
Space Sensor 4 Failure	BI: 36	This alarm indicates that the digital Space Sensor #4 is not communicating with the main controller.
Space Sensor 5 Failure	BI: 37	This alarm indicates that the digital Space Sensor #5 is not communicating with the main controller.
Space Sensor 6 Failure	BI: 38	This alarm indicates that the digital Space Sensor #6 is not communicating with the main controller.



BACnet Properties for the VCCX-454-GH Controller Binary Inputs		
Parameter	Object	Description
Space Sensor 7 Failure	Bl: 39	This alarm indicates that the digital Space Sensor #7 is not communicating with the main controller.
Space Sensor 8 Failure	Bl: 40	This alarm indicates that the digital Space Sensor #8 is not communicating with the main controller.
Space Sensor 9 Failure	Bl: 41	This alarm indicates that the digital Space Sensor #9 is not communicating with the main controller.
Space Sensor 10 Failure	Bl: 42	This alarm indicates that the digital Space Sensor #10 is not communicating with the main controller.
Fan Proving Alarm	Bl: 43	This alarm indicates an airflow failure from the main fan. Heating and Cooling will be disabled.
Dirty Filter Alarm	Bl: 44	This alarm indicates that the filters are dirty.
Emergency Shutdown Alarm	Bl: 45	This alarm indicates that an emergency shutdown has been activated. Will shut the unit down.
High Supply Temp Cutoff	Bl: 46	The supply air has risen above the High SAT Cutoff Setpoint. Heating stages will deactivate, and the fan continues to run. An alarm is generated.
Low Supply Temp Cutoff	Bl: 47	The supply air has fallen below the Low SAT Cutoff Setpoint. Cooling stages will deactivate. After 10 minutes, the fan will deactivate, and an alarm is generated.
Missing Refrigeration Module #1	Bl: 48	Refrigerant Module #1 is configured but not detected.
Missing Refrigeration Module #2	Bl: 49	Refrigerant Module #2 is configured but not detected.
Missing Refrigeration Module #3	Bl: 50	Refrigerant Module #3 is configured but not detected.
Missing Refrigeration Module #4	Bl: 51	Refrigerant Module #4 is configured but not detected.
Missing Reheat Board	Bl: 52	The MHGR board is configured but not detected.
Missing LA Control Board #1	Bl: 53	LA Auxiliary board #1 is configured but not detected.
Missing LA Control Board #2	Bl: 54	LA Auxiliary board #2 is configured but not detected.
Missing 12 Relay Expansion Board	Bl: 55	The 12 Relay Expansion Board is configured but not detected.
Missing MODGAS Board	Bl: 56	This alarm indicates that the MODGAS-XWR2 series module is configured but not detected.
Space Reference Out of Tolerance	Bl: 57	Indicates that the BACnet Space Temperature is 5°F different or Humidity is 5% different than readings from sensors connected directly to the main controller.
Mechanical Heating Failure	Bl: 60	Indicates a mechanical heating failure alarm.
Space Sensor Failure Shutdown	Bl: 61	Indicates a Space Sensor failure shutdown.
High Control Temp Failure	Bl: 62	Indicates a High Control Temp failure.
Low Control Temp Failure	Bl: 63	Indicates a Low Control Temp failure.
High Control RH Failure	Bl: 64	Indicates a High Control RH failure.
Low Control RH Failure	Bl: 65	Indicates a Low Control RH failure.
A1 Compressor Enable	Bl: 70	Current status of the enable signal to Compressor A1.
A2 Compressor Enable	Bl: 71	Current status of the enable signal to Compressor A2.
A1 Compressor Alarms	Bl: 72	Indicates an RSM alarm is present on the A1 circuit.
A2 Compressor Alarms	Bl: 73	Indicates an RSM alarm is present on the A2 circuit.
A Circuit Defrost Switch	Bl: 74	Current status of the defrost switch on RSM#1.
A Circuit Water Proof of Flow	Bl: 75	Current status of the water flow switch on RSM#1.
A Circuit Emergency Shutdown Input	Bl: 76	Current status of the emergency shutdown input on RSM#1.



BACnet Properties for the VCCX-454-GH Controller Binary Inputs		
Parameter	Object	Description
A Circuit RSM Relay #1	BI: 77	Current status of relay 1 on RSM #1.
A Circuit RSM Relay #2	BI: 78	Current status of relay 2 on RSM #1.
A Circuit RSM Relay #3	BI: 79	Current status of relay 3 on RSM #1.
A Circuit RSM Relay #4	BI: 80	Current status of relay 4 on RSM #1.
A Circuit RSM Relay #5	BI: 81	Current status of relay 5 on RSM #1.
B1 Compressor Enable	BI: 90	Current status of the enable signal to Compressor B1.
B2 Compressor Enable	BI: 91	Current status of the enable signal to Compressor B2.
B1 Compressor Alarms	BI: 92	Indicates an RSM alarm is present on the B1 circuit.
B2 Compressor Alarms	BI: 93	Indicates an RSM alarm is present on the B2 circuit.
B Circuit Defrost Switch	BI: 94	Current status of the defrost switch on RSM #2.
B Circuit Water Proof of Flow	BI: 95	Current status of the water flow switch on RSM #2.
B Circuit Emergency Shutdown Input	BI: 96	Current status of the emergency shutdown input on RSM #2.
B Circuit RSM Relay #1	BI: 97	Current status of relay 1 on RSM #2.
B Circuit RSM Relay #2	BI: 98	Current status of relay 2 on RSM #2.
B Circuit RSM Relay #3	BI: 99	Current status of relay 3 on RSM #2.
B Circuit RSM Relay #4	BI: 100	Current status of relay 4 on RSM #2.
B Circuit RSM Relay #5	BI: 101	Current status of relay 5 on RSM #2.
C1 Compressor Enable	BI: 110	Current status of the enable signal to Compressor C1.
C2 Compressor Enable	BI: 111	Current status of the enable signal to Compressor C2.
C1 Compressor Alarms	BI: 112	Indicates an RSM alarm is present on the C1 circuit.
C2 Compressor Alarms	BI: 113	Indicates an RSM alarm is present on the C2 circuit.
C Circuit Defrost Switch	BI: 114	Current status of defrost switch on RSM #3.
C Circuit Water Proof of Flow	BI: 115	Current status of water flow switch on RSM #3.
C Circuit Emergency Shutdown Input	BI: 116	Current status of emergency shutdown input on RSM#3.
C Circuit RSM Relay #1	BI: 117	Current status of relay 1 on RSM #3.
C Circuit RSM Relay #2	BI: 118	Current status of relay 2 on RSM #3.
C Circuit RSM Relay #3	BI: 119	Current status of relay 3 on RSM #3.
C Circuit RSM Relay #4	BI: 120	Current status of relay 4 on RSM #3.
C Circuit RSM Relay #5	BI: 121	Current status of relay 5 on RSM #3.
D1 Compressor Enable	BI: 130	Current status of the enable signal to Compressor D1.
D2 Compressor Enable	BI: 131	Current status of the enable signal to Compressor D2.
D1 Compressor Alarms	BI: 132	Indicates an RSM alarm is present on the D1 circuit.
D2 Compressor Alarms	BI: 133	Indicates an RSM alarm is present on the D2 circuit.
D Circuit Defrost Switch	BI: 134	Current status of the defrost switch on RSM #4.
D Circuit Water Proof of Flow	BI: 135	Current status of the water flow switch on RSM #4.
D Circuit Emergency Shutdown Input	BI: 136	Current status of the emergency shutdown input on RSM #4.
D Circuit RSM Relay #1	BI: 137	Current status of relay 1 on RSM #4.
D Circuit RSM Relay #2	BI: 138	Current status of relay 2 on RSM #4.
D Circuit RSM Relay #3	BI: 139	Current status of relay 3 on RSM #4.
D Circuit RSM Relay #4	BI: 140	Current status of relay 4 on RSM #4.
D Circuit RSM Relay #5	BI: 141	Current status of relay 5 on RSM #4.

NOTE: Objects labeled BI are read-only.



Table 18: VCCX-454-GH Multi-State Inputs

BACnet Properties for the VCCX-454-GH Controller Multi-State Inputs				
Parameter	Object	Description	Limits	
			Low	High
Mode of Operation	MI:1	1 = Off 2 = Operating	1	2
HVAC Mode	MI: 2	1 = Grow 2 = Dry 3 = Fan 4 = Cool 5 = Heat 6 = Purge	1	6

Table 19: VCCX-454-GH Multi-State Values

BACnet Properties for the VCCX-454-GH Controller Multi-State Values				
Parameter	Object	Description	Limits	
			Low	High
Operating Mode	MV: 1	1 = Off 2 = Operating	1	2
HVAC Mode	MV: 2	1 = Grow 2 = Dry 3 = Fan 4 = Cool 5 = Heat 6 = Purge	1	6

13.4. VCCX-454-GH BACnet PICS

Table 20: VCCX-454-GH BACnet Protocol Implementation Conformance Statement

BACnet Protocol Implementation Conformance Statement	
Date:	December 2017
Vendor:	AAON, Inc.
Product:	VCCX-454-GH Controller
Product Model Number:	ASM01698
Product Version:	1.13
Product Description:	HVAC Unit Controller
BACnet Protocol Revision:	Revision 12 (ANSI/ASHRAE Standard 135-2010)
BACnet Protocol Implementation Conformance Statement	
K.1.2 BIBB – Data Sharing-ReadProperty-B (DS-RP-B)	
K.1.4 BIBB – Data Sharing-ReadPropertyMultiple-B (DS-RPM-B)	
K.1.8 BIBB – Data Sharing-WriteProperty-B (DS-WP-B)	
K.5.2 BIBB – Device Management-DynamicDeviceBinding-B (DM-DDB-B)	
K.5.4 BIBB – Device Management-DynamicObjectBinding-B (DM-DOB-B)	
K.5.6 BIBB – Device Management-DeviceCommunicationControl-B (DM-DCC-B)	
BACnet Standardized Device Profile	
L.4 BACnet Application Specific Controller (B-ASC)	
Standard Object Types Supported	
Analog Input:	Optional properties supported: Description
Analog Value:	Optional properties supported: Description
Binary Input:	Optional properties supported: Description, Inactive_Text, Active_Text
Binary Value:	Optional properties supported: Description, Inactive_Text, Active_Text
Device Object:	Optional properties supported: Description, Location
Multi-state Input:	Optional properties supported: Description, State_Text
Multi-State Value:	Optional properties supported: Description, State_Text
NOTE: For all supported objects, the device does not support CreateObject or DeleteObject. There are no proprietary objects.	
Data Link Layer Options	
MS/TP Master: Supported Baud rates: 9.6K, 19.2K, 38.4K, 57.6K, 76.8K	
Segmentation Support	
Neither segmented requests nor segmented responses are supported.	



14. REVISION HISTORY

VCCX-454-GH Controller Technical Guide Change Log	
Revision and Date	Change
Rev A, January 06, 2025	Initial Release
Rev B, February 26, 2025	Updated Failure Alarms Mode
Rev C, May 11, 2026	Updated Document Formatting



AAON Controls Support:

Support.Controls@aaon.com

Controls Support Website:

www.aaon.com/aaon-controls-technical-support

AAON Factory Technical Support:

Technical.Support@aaon.com

Phone:

866-918-1100

Monday through Friday, 7:00 AM to 5:00 PM Central Time

Before calling Technical Support, have the model and serial number of the unit available.

For replacement parts, contact your local AAON Representative.

Are you an AAON Rep? Visit My AAON to open new support tickets, communicate directly with our support teams, and track your support progress in one place.

It is the intent of AAON to provide accurate and current product information. However, in the interest of product improvement, AAON reserves the right to change pricing, specifications, and/or design of its product without notice, obligation, or liability.

AAON® is a registered trademark of AAON, Inc., Tulsa, OK. BACnet® is a registered trademark of ASHRAE Inc., Atlanta, GA. BITZER is a registered trademark of BITZER® Kühlmaschinenbau GmbH. Copeland Scroll™ is a registered trademark of Emerson Electric Co., Saint Louis, Mo.

Copyright © AAON, all rights reserved throughout the world.

AAON® is a registered trademark of AAON, Inc., Tulsa, OK. AAON® assumes no responsibility for errors or omissions in this document.

This document is subject to change without notice.