





## RM454-Z PARTS REFERENCE

Table 1: RM454-Z Parts Reference

RM454-Z Parts Reference	
Part Description	Part Number
RM454-Z Module	ASM07717
VCCX-454 Controller	ASM07503
RM454-SC (Subcool Monitor)	ASM07719
Reheat Expansion Module	ASM01687
E-BUS Cable Assembly E-BUS Power & Comm 1.5 ft., 3 ft., 10 ft., 25 ft., 50 ft., 75 ft., 100 ft., 150 ft., 250 ft., and 1000 ft. Spool.	G029440 (1.5 ft.), G012870 (3 ft.), G029460 (10 ft.), G045270 (25 ft.), G029510 (50 ft.), G029530 (75 ft.), G029450 (100 ft.), G029470 (150 ft.), V36590 (250 ft.), G018870 (1000 ft. SPOOL).
E-BUS Adapter Hub with 1.5 ft. E-BUS Cable	ASM01635
E-BUS Adapter Board	ASM01878



## TABLE OF CONTENTS

1. NOTES, CAUTIONS, AND WARNINGS .....	1
2. GENERAL INFORMATION .....	2
2.1. Overview and System Requirements.....	2
2.2. Dimensions .....	3
3. INSTALLATION AND WIRING .....	4
3.1. Electrical and Environmental Requirements.....	4
4. INPUTS AND OUTPUTS .....	6
4.1. Input/Output Maps.....	6
5. WIRING .....	7
5.1. RM454-Z Inputs Wiring - Modules 1, 2, 4, and 5.....	7
5.2. RM454-Z Output Wiring - Modules 1, 2, 4, and 5.....	8
5.3. RM454-Z Input Wiring - Modules 3 and 6 .....	9
5.4. RM454-Z Output Wiring - Modules 3 and 6 .....	10
5.5. Reheat Expansion Module.....	11
5.6. RM454-SC (Subcool Monitor) Module.....	12
6. SEQUENCE OF OPERATIONS.....	13
6.1. Mode of Operation.....	13
6.2. Alarms .....	15
6.3. RM454-SC (Subcool Monitor) Module Operation.....	19
7. LCD SCREENS .....	20
7.1. Display Screen and Navigation Keys .....	20
7.2. RM454-Z Screens Map.....	21
7.3. RM454-Z Screen Descriptions .....	22
7.4. RM454-Z Alarms, Faults, and Lockouts .....	24
7.5. RM454-Z Danfoss Screens .....	25
7.6. RM454-SC (Subcool Monitor) Screens Map .....	26
7.7. RM454-SC (Subcool Monitor) Module Screen Descriptions.....	27
8. APPENDIX A: TROUBLESHOOTING .....	29
8.1. RM454-Z LED Diagnostic .....	29
8.2. RM454-SC (Subcool Monitor) LED Diagnostics.....	31
8.3. Reheat Expansion Module LED Diagnostics.....	32
8.4. Temperature Sensor Testing.....	34
8.5. Suction Pressure Transducer Testing .....	35
8.6. Liquid Line and Head Pressure Transducer.....	36



9. APPENDIX B: DANFOSS VFD..... 37

    9.1. Parameter Configurations ..... 37

10. APPENDIX C: SYSTEM CONFIGURATION ..... 38

    10.1. Module and Condenser Configuration in Prism 2 ..... 38

11. REVISION HISTORY ..... 40



## TABLE OF FIGURES

Figure 1: RM454-Z Dimensions .....	3
Figure 2: RM454-Z Inputs Wiring - Modules 1, 2, 4, and 5 .....	7
Figure 3: RM454-Z Outputs Wiring - Modules 1, 2, 4, and 5.....	8
Figure 4: RM454-Z Inputs Wiring - Modules 3 and 6 .....	9
Figure 5: RM454-Z Outputs Wiring - Modules 3 and 6 .....	10
Figure 6: Reheat Expansion Module #1 or #2 Wiring.....	11
Figure 7: Subcool Monitor Module Wiring .....	12
Figure 8: LCD Display and Navigation Keys.....	20
Figure 9: RM454-Z Screens Maps .....	21
Figure 10: RM454-SC (Subcool Monitor) Screens Map .....	26
Figure 11: RM454-Z LED Locations .....	30
Figure 12: Subcool Monitor LED Locations .....	31
Figure 13: Reheat Expansion LED Locations and Descriptions .....	33
Figure 14: RM454-Z Module Configuration .....	38
Figure 15: Prism 2 RM454-Z Configuration Page .....	38
Figure 16: Configuration of Emergency Shutdown Input .....	38
Figure 17: Low Ambient Kits Installation Options .....	38
Figure 18: Condenser Configuration Options.....	39
Figure 19: Modulating HPC Setpoint Options .....	39
Figure 20: Low Load Configuration Options.....	39



## TABLE OF TABLES

Table 1: RM454-Z Parts Reference .....	ii
Table 2: Electrical and Environmental Requirements .....	4
Table 3: RM454-Z Inputs and Outputs .....	6
Table 4: Subcool Monitor Inputs and Outputs .....	6
Table 5: Reheat Expansion Module Outputs .....	6
Table 6: Navigation Key Functions.....	20
Table 7: RM454-Z Main Screens.....	22
Table 8: RM454-Z System Status Screens .....	22
Table 9: RM454-Z Sensor Status Screens.....	23
Table 10: RM454-Z Setpoint Status Screens .....	23
Table 11: RM454-Z Alarms Screens.....	24
Table 12: RM454-Z Faults Screens .....	24
Table 13: RM454-Z Lockouts Screens.....	25
Table 14: RM454-Z Danfoss Screens .....	25
Table 15: RM454-Z SC Main Screens.....	27
Table 16: RM454-SC Circuit Status Screens.....	27
Table 17: RM454-SC Alarm Screens .....	28
Table 18: RM454-SC Setpoint Screens.....	28
Table 19: Status LED Blink Codes .....	29
Table 20: Reheat Expansion Module Alarm LED Blink Codes.....	32
Table 21: 0-5V Temperature Sensor - Voltage and Resistance for Type III Sensors .....	34
Table 22: Suction Pressure Transducer Chart for R454-B Refrigerant (Vapor).....	35
Table 23: 0-667 psi Transducer Chart .....	36
Table 24: Danfoss VFD Parameter Configurations.....	37

# 1. NOTES, CAUTIONS, AND WARNINGS

**Note:** Notes are intended to clarify the unit installation, operation, and maintenance.

 **CAUTION**

Caution statements are given to prevent actions that may result in equipment damage, property damage, or personal injury.

 **WARNING**

Warning statements are given to prevent actions that could result in equipment damage, property damage, or serious personal injury.

 **DANGER**

Danger statements are given to prevent actions that will result in equipment destruction, property damage, and severe personal injury or death.

## 2. GENERAL INFORMATION

### 2.1. Overview and System Requirements

#### 2.1.1. RM454-Z Features & Applications



#### CAUTION

This module is intended to function with units operating with R-454B refrigerant.

The Refrigerant System Module for VFD Compressors (RM454-Z) monitors and controls one refrigeration circuit of the HVAC unit. The RM454-Z is used on RZ units and on RN-E units with Danfoss compressors.

The RM454-Z is connected to an AAON unit controller. Three or six RM454-Z Modules can be connected, depending on the size of the system. There are two E-BUS expansion ports which allow the use of communicating sensors and the E-BUS Modules. There is a MODBUS terminal block which allows wiring to the Reheat Expansion Module or VFD Compressor.

The RM454-Z provides four analog inputs, four binary inputs, four relays, and two analog outputs. See Figures 2 through 7, pages 7 through 12 for wiring.

The RM454-Z Module provides the following:

- Modulates the compressors to satisfy the Suction Coil (Saturated) Temperature. The Suction Coil (Saturated) Temperature Setpoint is reset by the AAON unit controller to maintain the Supply Air Temperature during Cooling Mode. During Dehumidification Mode, it controls the compressors to the Suction (Saturation) Temperature Setpoint.
- Modulates the condenser fan or valve to maintain the Head Pressure Setpoint.
- Monitors the performance of the superheat controller to maintain the Superheat Setpoint of each evaporator coil.
- Provides alarms and safeties for the compressor and condenser operation.
- Provides a 2 x 8 LCD character display and four buttons that allow for status of system operation, system setpoints, system configurations, sensors, alarms, and to change the module's address, if necessary.

## 2.2. Dimensions

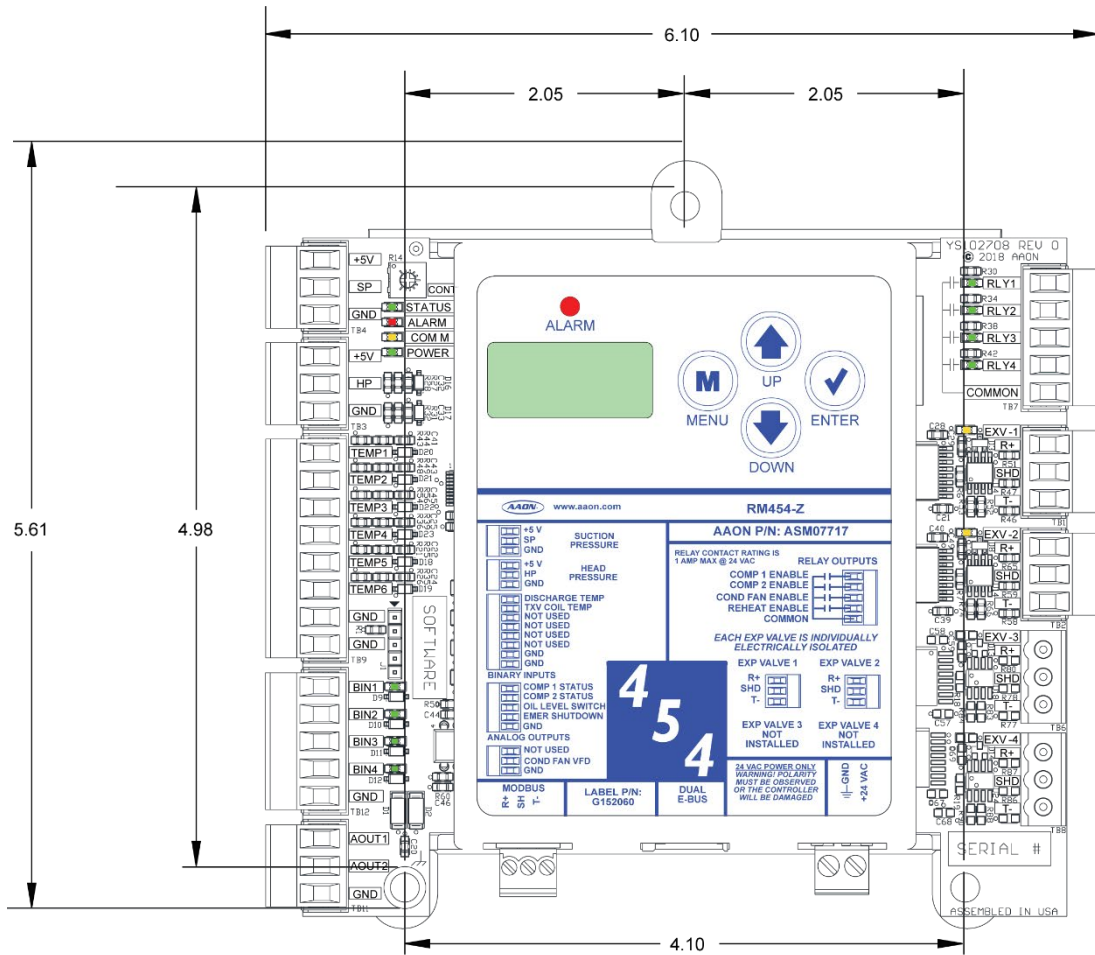

Note: All Dimensions are in inches.

Note: Depth is 1.50 inches.

Figure 1: RM454-Z Dimensions

## 3. INSTALLATION AND WIRING

### 3.1. Electrical and Environmental Requirements

#### 3.1.1. General

Correct wiring of the AAON unit controller and its modules is the most important factor in the overall success of the controller installation process. The AAON unit controller and modules are installed and wired at the AAON factory. Some of the following information may not apply to your installation if it was pre-wired at the factory. However, if troubleshooting of the controller or modules is required, it is a good idea to be familiar with the system wiring.

#### 3.1.2. Wiring

The modules must be connected to an 18-30 VAC power source of the proper size for the calculated VA load requirements. All transformer sizing should be based on the VA ratings listed in Table 2 below.

Table 2: Electrical and Environmental Requirements

Control Device	Voltage	VA Load	Operating Temperature	Humidity (Non-Condensing)
RM454-Z, Subcool Monitor, and Reheat Expansion Modules	18-30 VAC	18	-22°F to 158°F -30°C to 70°C	0-95% RH
	Inputs		Resistive Inputs require 10KΩ Type 3 Thermistor 24 VAC Inputs provide 4.7kΩ Load	
	Outputs		Relay Outputs: 1 Amp maximum per output.	

**Note:** If the temperature at the module is below -22°F (-30°C), the display refresh rate could be less responsive.



#### WARNING

When using a single transformer to power more than one controller or expansion module, the correct polarity must always be maintained between the boards. Failure to observe correct polarity will result in damage to the unit controller, RM454-Z, and any associated module.



Please carefully read and apply the following information when wiring the unit controller, RM454-Z, and any associated module.

1. All wiring is to be in accordance with local and national electrical codes and specifications.
2. All 24 VAC wiring must be connected so that all ground wires remain common. Failure to follow this procedure can result in damage to the controller and connected devices.
3. Minimum wire size for 24 VAC wiring should be 18-gauge.
4. Minimum wire size for all sensors should be 24-gauge. Some sensors require two-conductor wire and some require three-or four-conductor wire.
5. Minimum wire size for 24 VAC thermostat wiring should be 22-gauge.
6. Be sure that all wiring connections are properly inserted and tightened into the terminal blocks. Do not allow wire strands to stick out and touch adjoining terminals which could potentially cause a short circuit.
7. When communication wiring is to be used to interconnect AAON unit controllers together or to connect to other communication devices, all wiring must be plenum-rated, minimum 18-gauge, two-conductor, twisted-pair with shield. AAON can supply communication wire that meets this specification and is color coded for the network or local loop. Please consult your AAON distributor for information. If desired, Belden #82760 or equivalent wire may also be used.
8. Before applying power to the AAON unit controller, RM454-Zs, and any associated modules, be sure to recheck all wiring connections and terminations thoroughly.

### 3.1.3. Powering Up

When the controller and modules are first powered up, the POWER LED should light up and stay on continuously. If it does not light up, check to be sure that you have 24 VAC connected to the controller, that the wiring connections are tight, and that they are wired for the correct polarity. The 24 VAC power must be connected so that all ground wires remain common. If after making all these checks, the POWER LED does not light up, please contact AAON Controls Support for assistance.

## 4. INPUTS AND OUTPUTS

### 4.1. Input/Output Maps

See Table 3 for the RM454-Z Module inputs and outputs, Table 4 for the Subcool Monitor Module inputs and outputs, and Table 5 for the Reheat Expansion Module inputs and outputs.

Table 3: RM454-Z Inputs and Outputs

RM454-Z Module	
Analog Inputs	
1	Suction Pressure Transducer (SP)
2	Head Pressure Transducer (HP)
3	Discharge Temperature Sensor (TEMP1)
4	TXV Coil Temp (TEMP2)
Binary Inputs	
1	Compressor 1 Status (BI1)
2	Compressor 2 Status (BI2)
3	Oil Level Switch (BI3)
4	Emergency Shutdown (BI4)
Analog outputs (0-5 VDC)	
1	Not Used (AO1)
2	Condenser Fan VFD (AO2)
Relay Outputs (24 VAC)	
1	Compressor 1 Enable (RLY1)
2	Compressor 2 Enable (RLY2)
3	Condenser Fan Enable (RLY3)
4	Reheat Enable (RLY4)
Superheat Controller Communication Terminals	
1	Expansion Valve 1 (EXV-1)
2	Expansion Valve 2 (EXV-2)
3	Not Installed (EXV-3)
4	Not Installed (EXV-4)
Communication Terminals	
Dual E-BUS	2 EBC E-BUS Ports
MODBUS	MODBUS Communication Terminal Block

Table 4: Subcool Monitor Inputs and Outputs

Subcool Monitor Module	
Analog Inputs	
1	Liquid Line Pressure Transducer 1 (SP-1)
2	Liquid Line Pressure Transducer 2 (HP-1)
3	Liquid Line Pressure Transducer 3 (SP-2)
4	Not Used
Temperature Inputs	
1	Liquid Line Temperature 1 (TEMP1)
2	Liquid Line Temperature 2 (TEMP2)
3	Liquid Line Temperature 3 (TEMP3)
Communication Terminals	
Dual E-BUS	2 E-BUS Ports

Table 5: Reheat Expansion Module Outputs

Reheat Expansion Module	
Analog Output	
1	HGR Valve
Binary Input (24 VAC)	
1	Reheat Enable Input
Communication Terminals	
COMM	Communication Terminal Block

## 5. WIRING

### 5.1. RM454-Z Inputs Wiring - Modules 1, 2, 4, and 5

#### 5.1.1. RM454-Z Input Wiring

The RM454-Z monitors and controls one refrigeration circuit of the HVAC unit. The RM454-Z is used on RZ units and on RN-E units with Danfoss compressors. The module is designed for R410-A refrigerant.

The RM454-Z is connected to the AAON unit controller. Three or six RM454-Z Modules can be connected, depending on the size of the system. There are two E-BUS Expansion Ports which allow the use of communicating sensors and E-BUS Modules. There is a MODBUS terminal block which allows wiring to the Reheat Expansion Module or VFD Compressor.

The RM454-Z must be connected to an 18-30 VAC power source. When wiring the RM454-Z, its relay outputs must be wired as wet contacts (connected to 24 VAC). See Figure 2 below for RM454-Z input wiring for modules 1, 2, 4, and 5.

**Note:** The Suction Pressure Transducer and TXV Line Temperature sensor are only needed if TXVs are installed instead of EXVs.

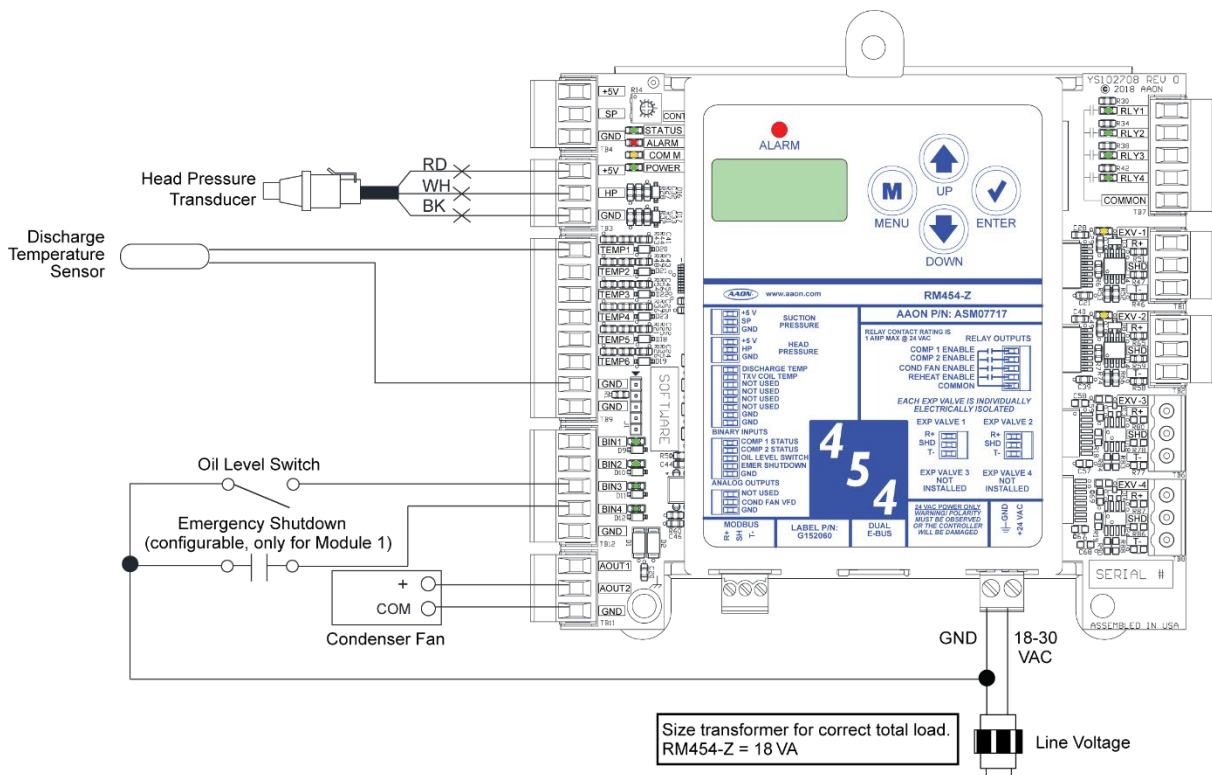

Figure 2: RM454-Z Inputs Wiring - Modules 1, 2, 4, and 5

## 5.2. RM454-Z Output Wiring - Modules 1, 2, 4, and 5

### 5.2.1. RM454-Z Output Wiring

See Figure 3 below for the RM454-Z outputs wiring for modules 1, 2, 4, and 5.

**WARNING**

Observe Polarity! All boards must be wired with GND-to-GND and 24 VAC-to-24 VAC. Failure to observe polarity will result in damage to one or more of the boards.

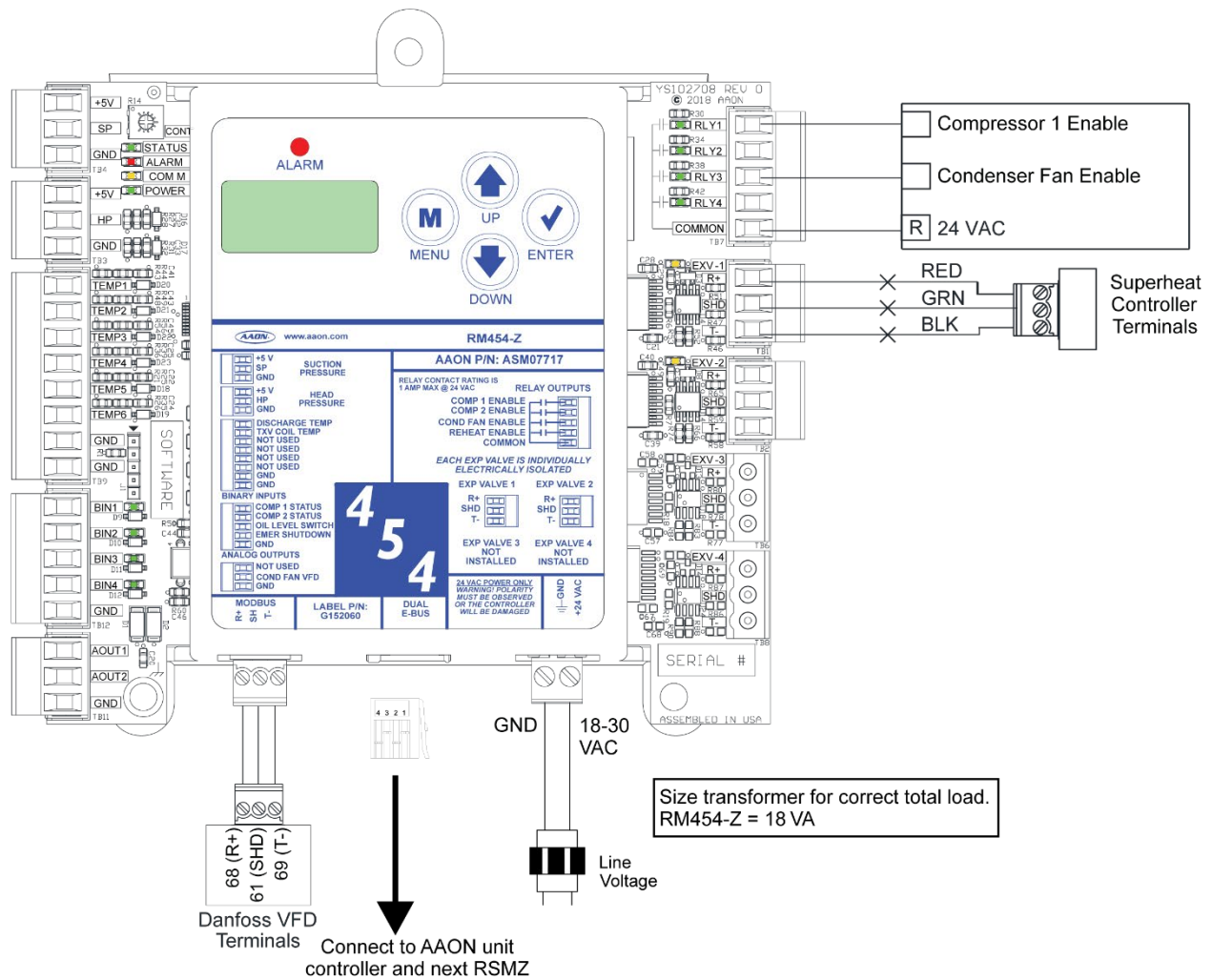

Figure 3: RM454-Z Outputs Wiring - Modules 1, 2, 4, and 5

## 5.3. RM454-Z Input Wiring - Modules 3 and 6

### 5.3.1. RM454-Z Input Wiring

See Figure 4 below for the RM454-Z outputs wiring for modules 3 and 6.

**WARNING**

Observe Polarity! All boards must be wired with GND-to-GND and 24 VAC-to-24 VAC. Failure to observe polarity will result in damage to one or more of the boards.

**Note:** The Suction Pressure Transducer and TXV Line Temperature sensor are only needed if TXVs are installed instead of EXVs.

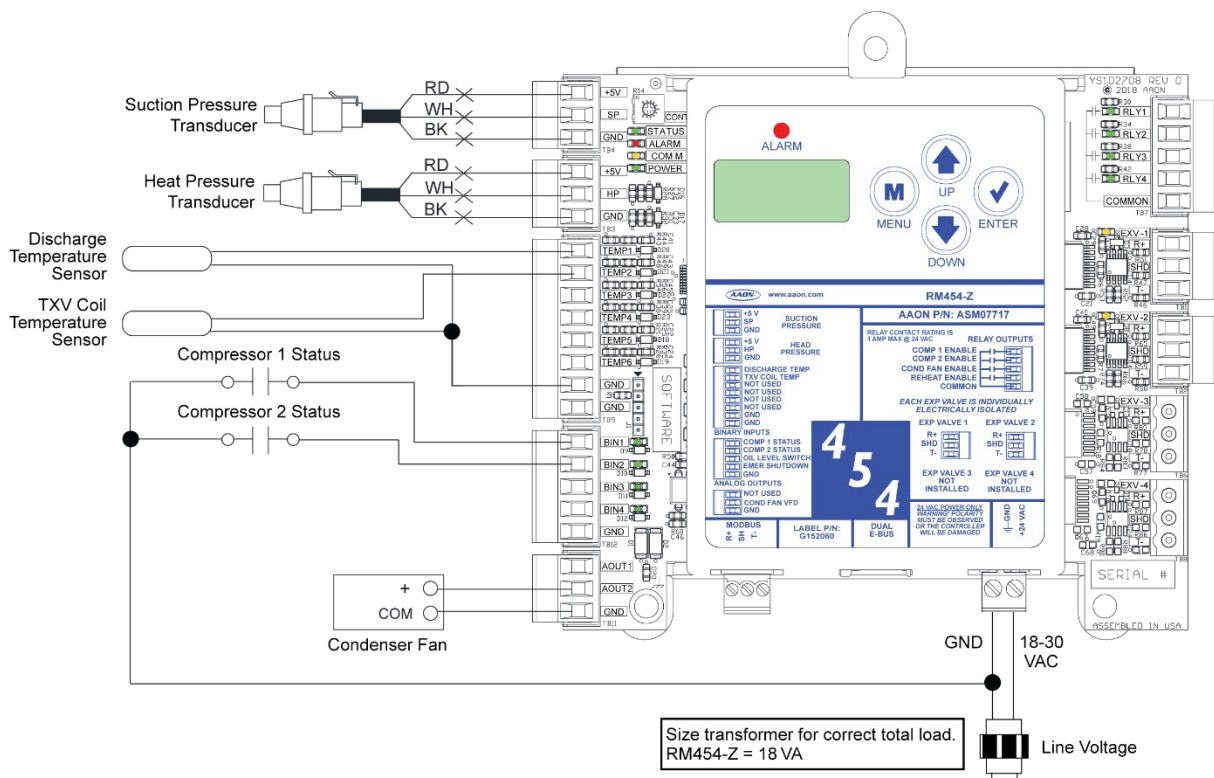

Figure 4: RM454-Z Inputs Wiring - Modules 3 and 6

## 5.4. RM454-Z Output Wiring - Modules 3 and 6

### 5.4.1. RM454-Z Output Wiring

See Figure 5 below for the RM454-Z outputs wiring for modules 3 and 6.

**WARNING**

Observe Polarity! All boards must be wired with GND-to-GND and 24 VAC-to-24 VAC. Failure to observe polarity will result in damage to one or more of the boards.

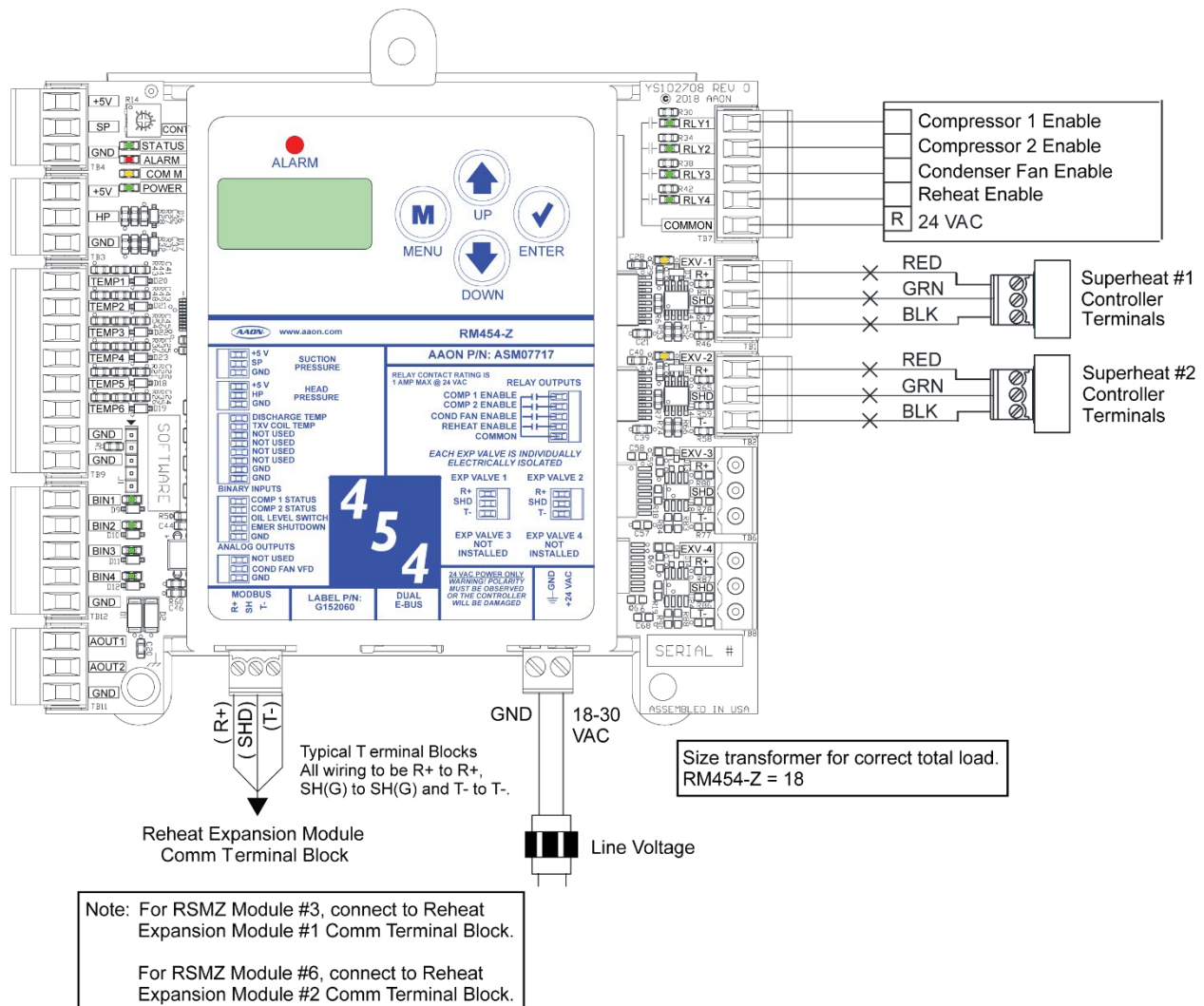

Figure 5: RM454-Z Outputs Wiring - Modules 3 and 6

## 5.5. Reheat Expansion Module

### 5.5.1. Reheat Expansion Module Wiring

The Reheat Expansion Module connects to the RM454-Z Communication Terminal Block. One or two Reheat Expansion Modules are used per system.

The Reheat Expansion Module must be connected to an 18-30 VAC power source.

See Figure 6 below for wiring.

**Note:** Please refer to the MHGRV-X Technical Guide for more information.



### WARNING

Observe Polarity! All boards must be wired with GND-to-GND and 24 VAC-to-24 VAC. Failure to observe polarity will result in damage to one or more of the boards.

Size transformer for correct total load.  
Reheat Expansion Module = 18 VA

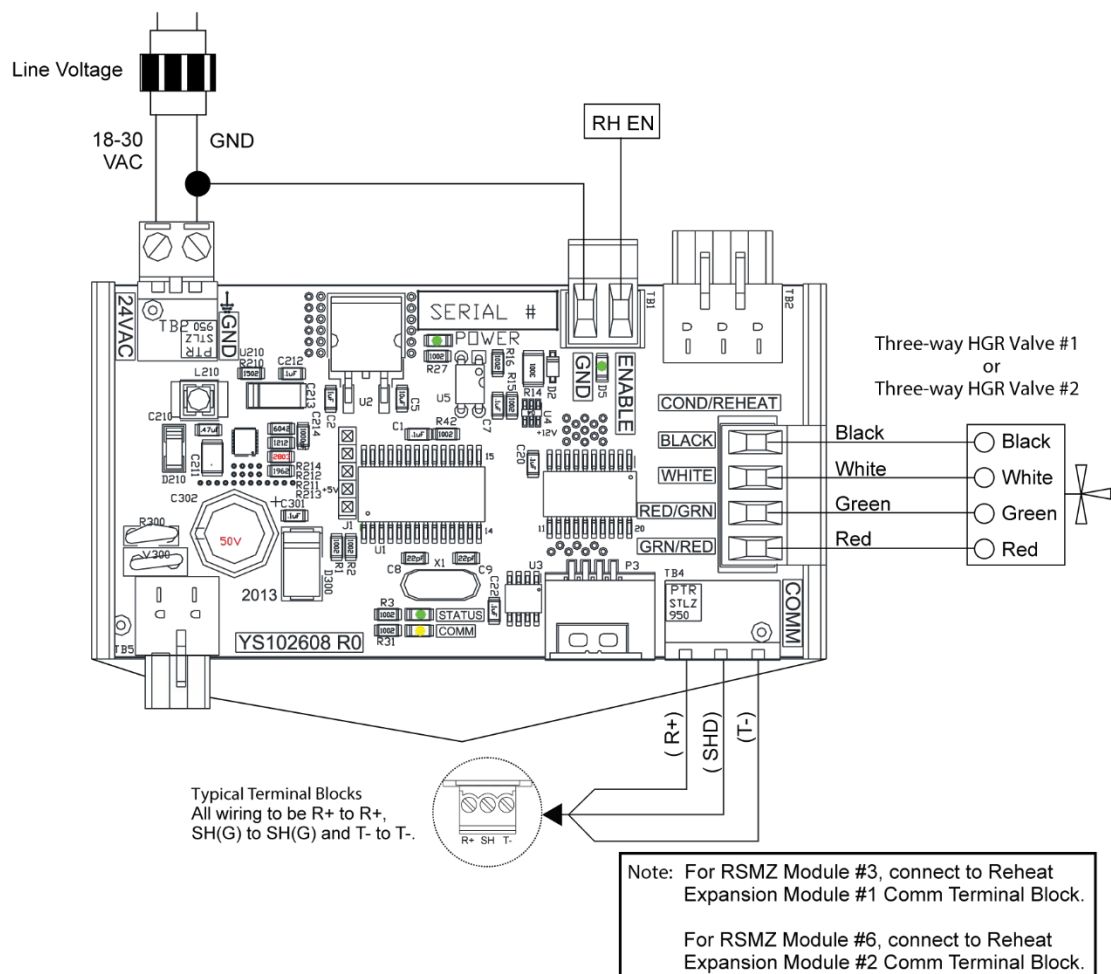

Figure 6: Reheat Expansion Module #1 or #2 Wiring

## 5.6. RM454-SC (Subcool Monitor) Module

### 5.6.1. Wiring

The use of the RM454-SC is optional. The module reads the Liquid Line Temperature Sensors to calculate subcooling. This module can be configured to work with R454-B refrigerant.

The Subcool Monitor Module is connected to the AAON unit controller. One or two Subcool Monitor Modules can be connected, depending on the size of the system.

The Subcool Monitor Module contains a 2 x 8 LCD character display and four buttons that allow for status and alarm display.

The Subcool Monitor Module must be connected to an 18-30 VAC power source.

See Figure 7 below for wiring.

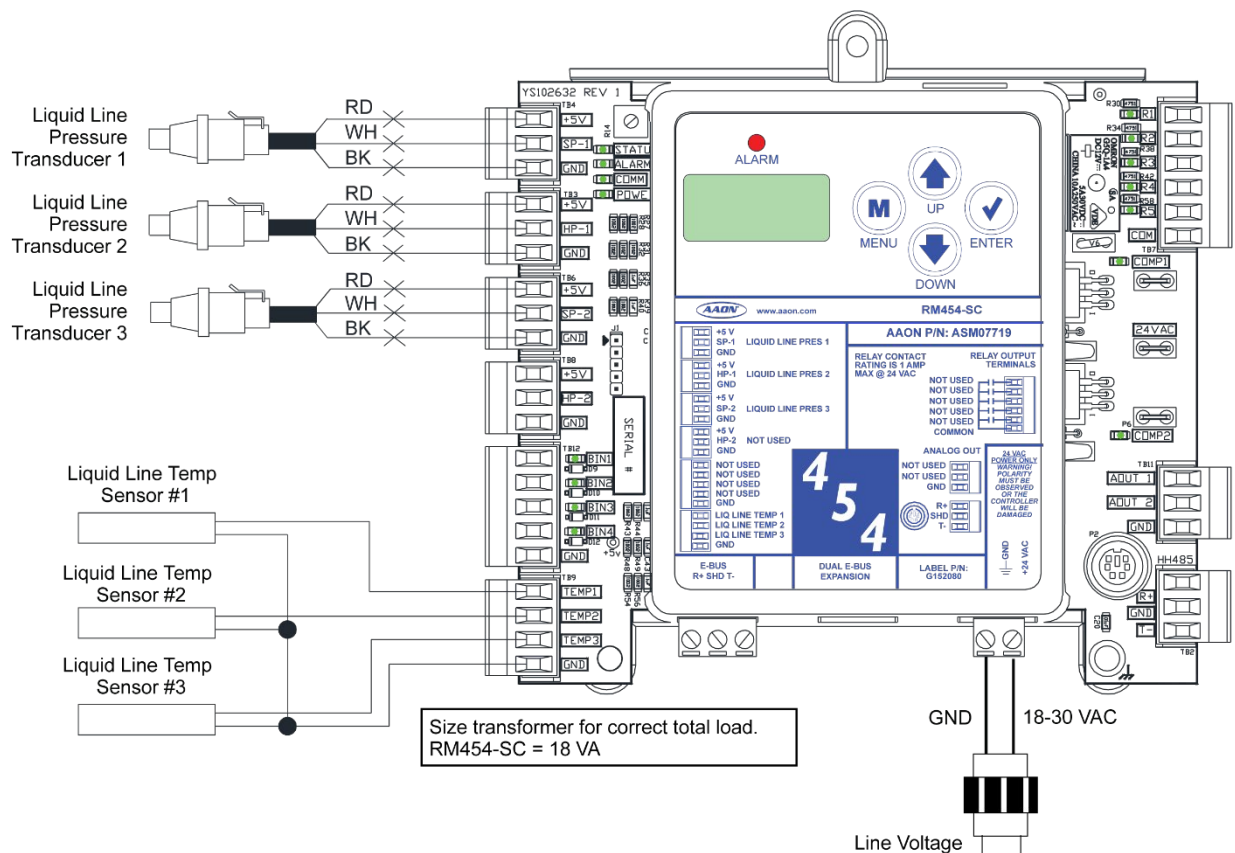

Figure 7: Subcool Monitor Module Wiring

## 6. SEQUENCE OF OPERATIONS

### 6.1. Mode of Operation

#### 6.1.1. Overview

The RM454-Z may be configured to operate as any one of six possible modules in the control system. This configuration automatically adjusts depending on the address of each module. All systems will consist of either three modules or six modules.

RM454-Z control is a three or six circuit cooling system with Reheat. The six circuit system is effectively two, three-circuit systems operating in parallel. There is some overlap of controls to ensure that the two systems operate in the same mode.

Modules at addresses 1, 2, 4, and 5 will each control a variable speed circuit (single Danfoss scroll compressor) and represent half of the evaporative face. Superheat is controlled by a Superheat Controller, and there is no Reheat.

Modules at addresses 3 and 6 have two tandem fixed compressors, full evaporative face through two parallel evaporators interlaced with the variable compressor-controlled circuits. Evaporator Superheat is not controlled by a Superheat Controller, unlike Circuits A and B. Circuit C only monitors the Superheat as calculated by the Suction Pressure (Saturated Suction temp) and Temp 2 input on the RM454-Z. These circuits also have parallel Reheat with a three-way valve to Control Feed to the Reheat coils or the condenser. 100% Reheat is possible.

Sequencing depends on the particular operation—Cooling Mode or Dehumidification Mode.

#### 6.1.2. Modes of Operation

There are three basic modes of operation for this module:

- Off Mode
- Cooling Mode
- Dehumidification Mode

When changing modes, the mode will first be commanded to RM454-Z Module 1, and that module will then share the mode change with the other RM454-Z Modules so that all modules will operate in the same mode. If the RM454-Z Module 1 goes offline for any reason, then the DX coil operations will be stopped for the entire unit.

##### 6.1.2.1. Off (Stop) Mode

During Emergency Off Mode, all compressor(s) will immediately stop, regardless of run time.

During regular Off Mode, all compressor(s) will turn off after they have met their minimum run times. The condenser fan will then be disabled, and the condenser fan control output will be set to 0V. The DX staging sequence will stop, and the module status will change to off.

During Off Mode, monitoring continues to provide status information, and alarms remain activated unless otherwise indicated.

##### 6.1.2.2. Cooling Mode

During startup of the Cooling Mode, the RM454-Z receives communication from the AAON unit controller to indicate Cooling Mode, which is then used to stage on cooling.

In Cooling Mode, the variable speed compressors are staged on together. If additional cooling is needed, the compressors on the tandem circuit will stage on.



### 6.1.2.3. Dehumidification Mode

During the startup of Dehumidification Mode, the RM454-Z receives communication from the unit controller to indicate Dehumidification Mode, which is used by the compressor staging sequence.

If the current state is “all compressors are off” for RM454-Z Module 3 or 6, dehumidification will begin once the minimum off time has been met for module 3's or 6's first compressor (E1/F1), and the condenser fan will modulate to the minimum condenser fan output value. Compressor E1/F1 for module 3 or 6 will then be enabled.

If the current state is “compressors A, B, C, and D are active” for modules 1, 2, 4, or 5, the compressors will modulate to the minimum position, wait for the minimum run time to be met, and then turn off. The compressors will then be disabled and turned off. Once the minimum off time has been met for modules 3 or 6 first compressor (E1/F1), the condenser fan will modulate to the minimum condenser fan output value. Compressor E1/F1 for module 3 or 6 will then be enabled.

If the current state is “all VFD”, and E1/F1 are active, module 3 or module 6 will wait for the minimum off time to be met for module 3 or 6 compressor E2/F2. Compressor E2/F2 will then be enabled.

## 6.2. Alarms

### 6.2.1. Alarm Detection and Reporting

The RM454-Z continuously performs self-diagnostics during normal operation to determine if any operating failures have occurred. These failures (alarms) will be reported to the AAON unit controller, which allows them to be monitored via a BACnet® Building Automation System or with a user interface.

The following are the available alarm designations with detailed descriptions for the RM454-Z.

### 6.2.2. Alarm Warnings

#### Low Suction Pressure Warning

Low Suction Pressure will be ignored for the first minute of initial compressor operation. If the suction pressure is below 77 psig for 20 seconds, the VFD compressor will modulate down 1% per second. This warning will clear once the Suction Pressure rises above 95 psig.

#### Low Suction Pressure – Startup Warning

The initial compressor on the circuit cannot start unless the Suction Pressure reaches a minimum PSIG depending on the outdoor air temperature.

- Above -25°F = 16.8 PSIG
- Above 0°F = 38.4 PSIG
- Above 25°F = 69.6 PSIG
- Above 50°F = 114.4 PSIG
- Above 75°F = 120 PSIG

#### High Discharge Pressure – Level 1 Warning

If the Discharge Pressure rises above 500 psig, the condenser fan will be forced to 100%. The VFD compressor will limit the minimum and maximum RPM limits from 1800 rpm to 5400 rpm, according to envelope protection.

#### High Discharge Pressure – Level 2 Warning

If the Discharge Pressure rises above 575 psig, the VFD compressor will modulate down 1% per second until the Discharge Pressure drops below 475 psig.

#### Discharge Pressure Not Detected Warning

If the Discharge Pressure Transducer is not detected and a compressor is running, the condenser fan will be forced to 100%.

#### Danfoss VFD Alarms Warning

If an alarm occurs from the VFD compressor, the Danfoss Alarm Menu screens will show information on what the alarm code is.

The screens break up the alarms into bytes. If a display is not installed on the VFD, these alarm bytes will aid in knowing which specific alarm has occurred.

- Parameter 16-90 Alarm Word 1 “DNFSALM1”
- Parameter 16-90, alarm bits 0 – 7 “DNFSALM1”, “B1 ###”
- Parameter 16-90, alarm bits 8 – 15 “DNFSALM1”, “B2 ###”
- Parameter 16-90, alarm bits 16 – 23 “DNFSALM1”, “B3 ###”
- Parameter 16-90, alarm bits 24 – 31 “DNFSALM1”, “B4 ###”
- Same with Parameter 16-91 Alarm Word 2 “DNFSALM2”

There are two alarm parameters from the VFD 16-90 and 16-91. Each contains 32 different alarms as a binary bitfield, each bit is a specific alarm. Refer to Danfoss “Operating Instructions” “VLT Compressor Drives CDS 302/CDS 303” that is provided with the unit.

#### High Superheat Warning

A high superheat warning will occur if a compressor is active and the superheat is above 25°F for two minutes or longer.



## **Alarm Warnings (Continued)**

### **High Discharge Line Temperature**

This sensor is installed for modulating VFD compressors only. If the Discharge Line Temperature rises above 260°F, the VFD compressor will modulate down 1% per second until the Discharge Line Temperature drops below 260°F.

### **Compressor 1 False Active Warning**

This warning will occur if Compressor 1 is not activated and the running verification signal is active for at least 45 seconds. For Danfoss VFD compressors, the running verification is sent from Modbus Communications. For fixed On/Off compressors, the running verification is a binary input signal to the module.

### **Compressor 2 False Active Warning**

This warning will occur if Compressor 2 is not activated and the running verification signal is active for at least 45 seconds. For Danfoss VFD compressors, the running verification is sent from Modbus Communications. For fixed On/Off compressors, the running verification is a binary input signal to the module.

### **Discharge Line Temp Sensor Not Detected**

This warning will occur if the Discharge Line Temperature Sensor is not detected by the module.

### 6.2.3. Alarm Faults

#### Low Suction Pressure Fault

Low Suction Pressure will be ignored for the first minute of initial compressor operation. If the suction pressure is below 77 psig for one minute, the compressor will be turned off and will be retried after five minutes.

#### Compressor 2 Low Suction Pressure Fault

Low Suction Pressure will be ignored for the first minute of initial compressor operation. For tandem circuits, if both compressors are running and the suction pressure is below 77 psig for one minute, the second compressor will be turned off and will be retried after five minutes.

#### Unsafe Suction Pressure Fault

Unsafe Suction Pressure Detection will be ignored for the first 30 seconds of initial compressor operation. If the Suction Pressure drops below 44 psig for five seconds, the compressor(s) will be turned off and will be retried after five minutes.

#### High Discharge Pressure Fault

On a single compressor circuit, if the Discharge Pressure rises above 575 psig, the compressor will be turned off and will be retried after five minutes. The compressor will not be reactivated until the pressure rises above 475 psig.

#### Compressor 2 High Discharge Pressure Fault

On a tandem compressor circuit, if the Discharge Pressure rises above 575 psig and both compressors are running, the second compressor will be turned off and will be retried after five minutes.

#### Compressor 1 Not Running Fault

If Compressor 1 has been activated for at least 45 seconds and the running verification signal is not active, the compressor signal will be turned off and will be retried after five minutes. For Danfoss VFD compressors, the running verification is sent from Modbus Communications. For fixed On/Off compressors, the running verification is a binary input signal to the module.

#### Compressor 2 Not Running Fault

If Compressor 2 has been activated for at least 45 seconds and the running verification signal is not active, the compressor signal will be turned off and will be retried after five minutes. For fixed On/Off compressors, the running verification is a binary input signal to the module.

#### Low Superheat Fault

The low superheat detection will be ignored for the first two minutes of initial compressor operation. If the superheat drops below 4°F for two minutes, the compressor signal will be turned off and will be retried after five minutes.

#### High Discharge Line Temperature

This sensor is installed for modulating VFD compressors only. If the Discharge Line Temperature rises above 260°F, the VFD compressor will modulate down 1% per second until the Discharge Line Temperature drops below 260°F.

If the compressor modulates down to 1800 rpm, the compressor will be turned off and will be retried if the Discharge Line Temperature drops below 150°F and five minutes have lapsed.



## **Alarm Faults (Continued)**

### **EXV Sensor Not Detected Fault**

If the superheat controller is not detected through Modbus communications for one minute, the compressor(s) will be turned off. This fault will be cleared when communication is reestablished.

### **Communications Loss Fault**

If E-BUS communications are lost for at least 15 seconds, the compressor(s) will be turned off. If the module is controlling a Danfoss VFD compressor and the Modbus communication to the Danfoss VFD compressor is lost for at least 15 seconds, the compressor will be turned off. This fault will be cleared when communication is reestablished.

### **High Superheat Fault**

If a compressor is active and the superheat is above 30°F for 10 minutes or longer, the compressor(s) will be turned off and will be retried after five minutes.

### **High Evaporator Saturation Temperature Fault**

On a tandem circuit, both compressors have to be running to trigger a fault. A modulating VFD compressor has to be at 100% to trigger a fault. If the Evaporator Saturation Temperature rises above 59°F for the stage up delay plus two minutes, the compressor will be turned off and will be retried after five minutes.

### 6.2.4. Alarm Lockouts

#### Low/Unsafe Suction Pressure Lockout

If a low Suction Pressure fault or unsafe Suction Pressure fault occurs three times in a two-hour time period, the circuit will be disabled and locked out until the module is reset.

#### Low Refrigerant Oil Level Lockout

If an oil boost cycle is performed and the oil level is not detected for one minute, the circuit will be disabled and locked out until the module is reset.

#### High Discharge Pressure Lockout

If a high Discharge Pressure fault occurs three times in a two-hour time period, the circuit will be disabled and locked out until the module is reset.

#### Low Superheat Lockout

If a low superheat fault occurs three times in a two-hour time period, the circuit will be disabled and locked out until the module is reset.

#### High Superheat Lockout

If a high superheat fault occurs three times in a two-hour time period, the circuit will be disabled and locked out until the module is reset.

#### High Evaporating Temperature Lockout

If a high evaporating temperature fault occurs three times in a two-hour time period, the circuit will be disabled and locked out until the module is reset.

#### High Discharge Line Temperature Lockout

If a high Discharge Line Temperature fault occurs three times in a two-hour time period, the circuit will be disabled and locked out until the module is reset.

## 6.3. RM454-SC (Subcool Monitor) Module Operation

### 6.3.1. Operation

The RM454-SC Module is a monitoring-only module. It is capable of monitoring the subcooling for up to three circuits simultaneously. The use of the RM454-SC is optional.

#### 6.3.1.1. Subcooling Sequence

The RM454-SC reads and scales all of its six inputs and calculates the saturation temperature and subcooling for each configured circuit.

## 7. LCD SCREENS

### 7.1. Display Screen and Navigation Keys

#### 7.1.1. LCD Display Screen and Navigation Keys

The LCD display screens and buttons allow for the viewing of statuses, alarms, and enable force modes. See Figure 8 below and refer to Table 6 for the button descriptions.

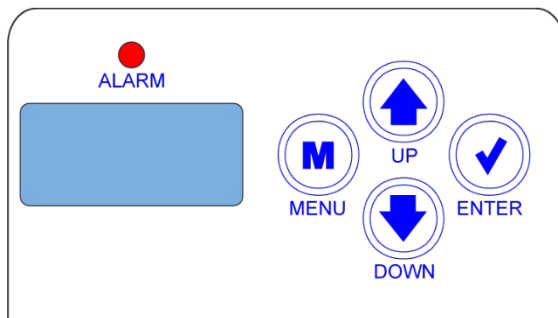

Figure 8: LCD Display and Navigation Keys

Table 6: Navigation Key Functions

Navigation Key Functions	
Key	Function
MENU 	Use the <b>&lt;MENU&gt;</b> key to move through screens within Main Menu categories and return to the Main Menu while at other screens.
UP 	Use this key to adjust setpoints and change configurations.
DOWN 	Use this key to adjust setpoints and change configurations.
ENTER 	Use the <b>&lt;ENTER&gt;</b> key to navigate through the Main Menu Screen categories.

## 7.2. RM454-Z Screens Map

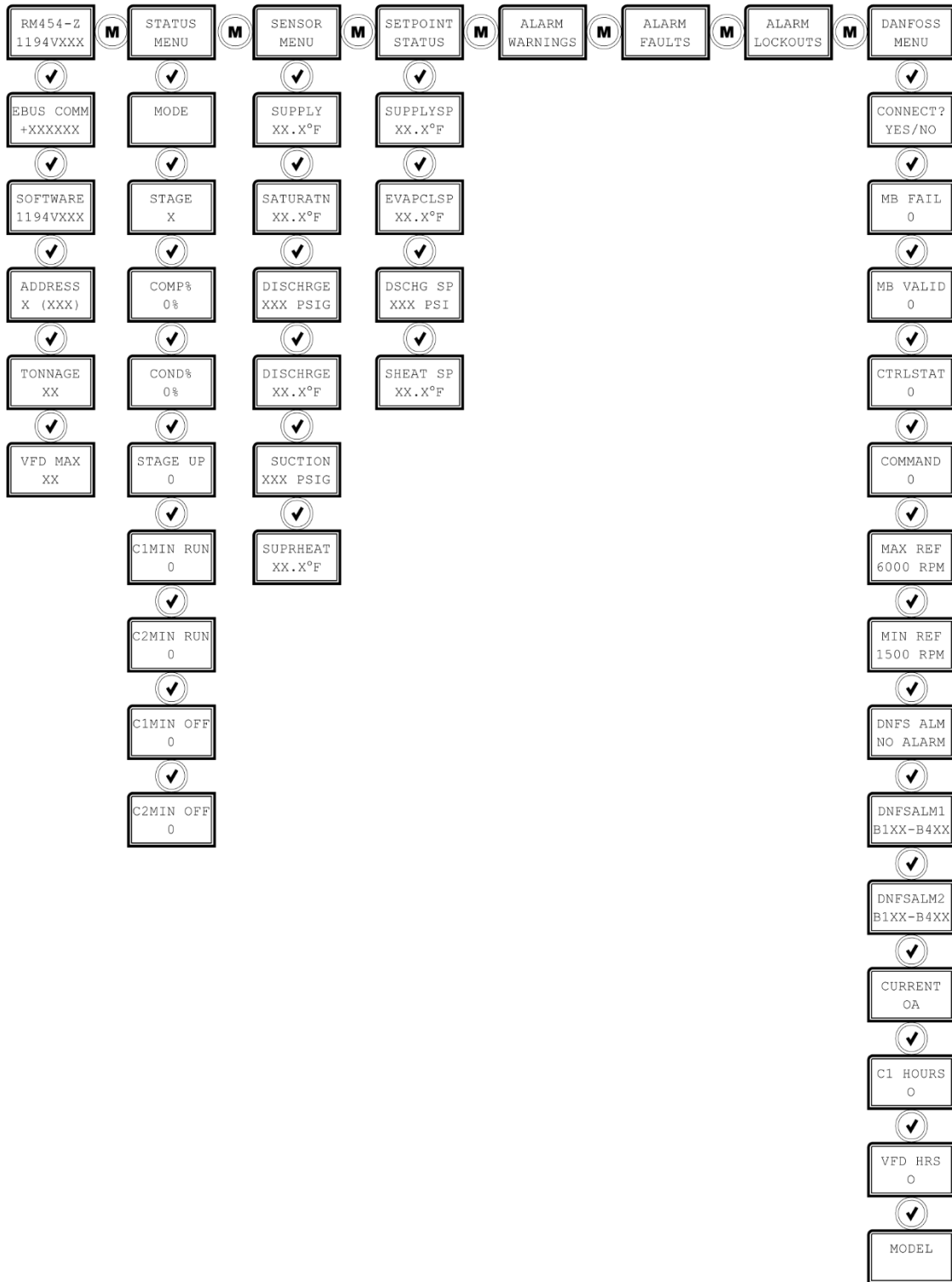

Figure 9: RM454-Z Screens Maps

## 7.3. RM454-Z Screen Descriptions

### 7.3.1. Main Screens

Refer to the following table when navigating through the LCD Main Screens.

Press the **<MENU>** button to navigate between the top level screens. Press the **<ENTER>** button to scroll through the next level screens.

Table 7: RM454-Z Main Screens

Main Screens	
Screen Text	Description
RM454-Z 1194vXXX	Refrigeration module screens. The second line shows the software number and its version.
EBUS COMM	Number of COMM packets received.
SOFTWARE 1194vXXX	Software version.
ADDRESS X (XXX)	<p>Configure the address according to which circuit this module represents.</p> <p>If three RM454-Z modules 1=A, 2=B, 3=C</p> <p>If six RM454-Z modules 1=A, 2=C, 3=E, 4=B, 5=D, 6=F</p> <p>The number in parentheses is the E-BUS address.</p> <p>Module 1's address is 177. Module 2's address is 178. Module 3's address is 179. Module 4's address is 180, Module 5's address is 181. Module 6's address is 182.</p>
TONNAGE XX	Unit tonnage.
VFD MAX XX	Maximum speed based on unit tonnage.

### 7.3.2. System Status Screens

Refer to the following map when navigating through the System Status Screens. From the SYSTEM STATUS Screen, press **<ENTER>** to scroll through the screens.

Table 8: RM454-Z System Status Screens

System Status Screens	
Screen Text	Description
STATUS MENU	System Status Screens
MODE	System mode. Options are: <ul style="list-style-type: none"> <li>• MIN RUN</li> <li>• OFF</li> <li>• COOLING</li> <li>• HEATING</li> <li>• DEHUM</li> <li>• FORCED</li> </ul>
STAGE X	Number of stages
COMP% 0%	Compressor status
COND% 0%	Condenser status
Stage Up 0	Stage up status
C1MIN RUN 0	Compressor 1 minimum run time
C2MIN RUN 0	Compressor 2 minimum run time
C1MIN OFF 0	Compressor 1 minimum off time
C2MIN OFF 0	Compressor 2 minimum off time

### 7.3.3. Sensor Status Screens

Refer to the following map when navigating through the Sensor Status Screens. From the SENSOR STATUS Screen, press <ENTER> to scroll through the screens.

Table 9: RM454-Z Sensor Status Screens

Sensor Status Screens	
Screen Text	Description
SENSOR STATUS	Sensor status screens
SUPPLY XX.X°F	Supply air temperature reading from input
SATURATN XX.X°F	Saturation temperature reading from input
DISCHARGE XXX PSIG	Discharge pressure reading from input
DISCHARGE XX.X°F	Discharge temperature reading from input
SUCTION XXX PSIG	Suction pressure reading from input
SUCTION XXX PSIG	Superheat reading from temperature sensor input

### 7.3.4. Setpoint Status Screens

Refer to the following map when navigating through the Setpoint Status Screens. From the SETPOINT STATUS Screen, press <ENTER> to scroll through the screens.

Table 10: RM454-Z Setpoint Status Screens

Setpoint Status Screens	
Screen Text	Description
SETPOINT STATUS	Setpoint Status screens
SUPPLYSP XX.X°F	Supply temperature setpoint
EVAPLSP XX.X°F	Evaporator coil temperature setpoint
DSCHG SP XXX PSI	Discharge pressure setpoint
SHEAT SP XX.X°F	Superheat setpoint

## 7.4. RM454-Z Alarms, Faults, and Lockouts

### 7.4.1. Alarms Screens

If an alarm, fault, or lockout is present, the ALARM LED above the LCD display lights up red and blinks. The alarms, faults, and lockouts scroll automatically from their respective screen when more than one message is present.

Table 11: RM454-Z Alarms Screens

Alarm Screens	
Screen Text	Description
ALARM WARNINGS	Alarm Status screens.
NO WARNINGS	This is shown if there are no current alarms.
WARNINGS!	This is shown if there are active alarms.
LOW SUCT PRESSURE	Low suction pressure.
LOW SUCT NO START	Low suction pressure at startup.
HIGH DISCHPSI	High discharge pressure.
DISCHPSI NODETECT	Discharge pressure not detected.
VFD ALARM	Danfoss VFD alarms.
HIGH SUPRHEAT	High superheat.
HIGH DISCTEMP	High discharge line temperature.
C1 FALSE ACTIVE	Compressor 1 false active.
C2 FALSE ACTIVE	Compressor 2 false active.
DLT NODETECT	Discharge line temperature sensor not detected.

Table 12: RM454-Z Faults Screens

Faults Screens	
Screen Text	Description
ALARM FAULTS	Alarm Faults screens.
NO FAULTS	This is shown if there are no current alarms.
FAULTS!	This is shown if there are active faults.
LOW SUCT PRESSURE	Low suction pressure.
UNSAFE SP	Unsafe suction pressure.
HIGH PSI TRIP	High discharge pressure trip.
HIGH PSI TRIP C2	Compressor 2 fail from high discharge pressure.
C1 NO START	Compressor 1 not running.
C2 NO START	Compressor 2 not running.
LOW SUPRHEAT	Low superheat.
HIGH DISCTEMP	High discharge line temperature.
EXV NODETECT	EXV sensor not installed.
COMM TIMEOUT	Communications loss.
C2 OFF LOW SUCT	Compressor 2 failed from low suction pressure.
HIGH SUPRHEAT	High superheat.
HIGH EVAPTEMP	High evaporator saturation temperature.

## 7.4.2. Lockout Screens

If an alarm, fault, or lockout is present, the ALARM LED above the LCD display lights up red and blinks. The alarms, faults, and lockouts scroll automatically from their respective screen when more than one message is present.

Table 13: RM454-Z Lockouts Screens

Lockout Screens	
Screen Text	Description
ALARM LOCKOUTS	Alarm Lockouts screens.
NO LOCKOUTS	This is shown if there are no current lockouts.
LOCKOUTS!	This is shown if there are active lockouts.
SUCT PSI LOCKOUT	Low or unsafe suction pressure.
LOW OIL LOCKOUT	Low refrigerant oil level.
HIGHDISC PSI L/O	High discharge pressure.
LOW SH LOCKOUT	Low superheat.
HIGH SH LOCKOUT	High superheat.
HIGHEVAP LOCKOUT	High evaporating temperature.
HIGHDISC TEMP L/O	High discharge line temperature.

## 7.5. RM454-Z Danfoss Screens

### 7.5.1. Danfoss Menu Screens

Refer to the following map when navigating through the Screens. From the DANFOSS MENU Screen, press <ENTER> to scroll through the screens.

Table 14: RM454-Z Danfoss Screens

Faults Screens	
Screen Text	Description
DANFOSS MENU	Danfoss Screens menu.
CONNECT? YES/NO	Danfoss connection status.
MB FAIL 0	MB fail.
MB VALID 0	BC valid.
CTRL STAT	Control Status  The following status message may be displayed in the second line: <ul style="list-style-type: none"> <li>• DRV STAT</li> <li>• ENABLED?</li> <li>• TRIP ERR</li> <li>• ALT ERR</li> <li>• TRIPLOCK</li> <li>• WARNING?</li> <li>• SPDvsREF</li> <li>• BUS CTRL</li> <li>• FREQ LIM</li> <li>• IN OPER?</li> <li>• STP/AUTO</li> <li>• VOLT LMT</li> <li>• TORQ LMT</li> <li>• TIME LMT</li> </ul>
COMMAND 0	Command status. Command speed to VFD. Range 0-100%.
MAX REF 6000 RPM	Max ref RPM.
MIN REF 1500 RPM	Min ref RPM.
DNFS ALM NO ALARM	Notifies if there is a Danfoss alarm present.
DNFSALM1 B1XX-B4XX	Danfoss 1 alarms. B1-B4 codes.
DNFSALM2 B1XX-B4XX	Danfoss 2 alarms. B1-B4 codes.
CURRENT OA	Current OA.
C1 HOURS 0	Compressor 1 hours.
VFD HRS 0	VFD hours.
MODEL	Danfoss model part number.

## 7.6. RM454-SC (Subcool Monitor) Screens Map

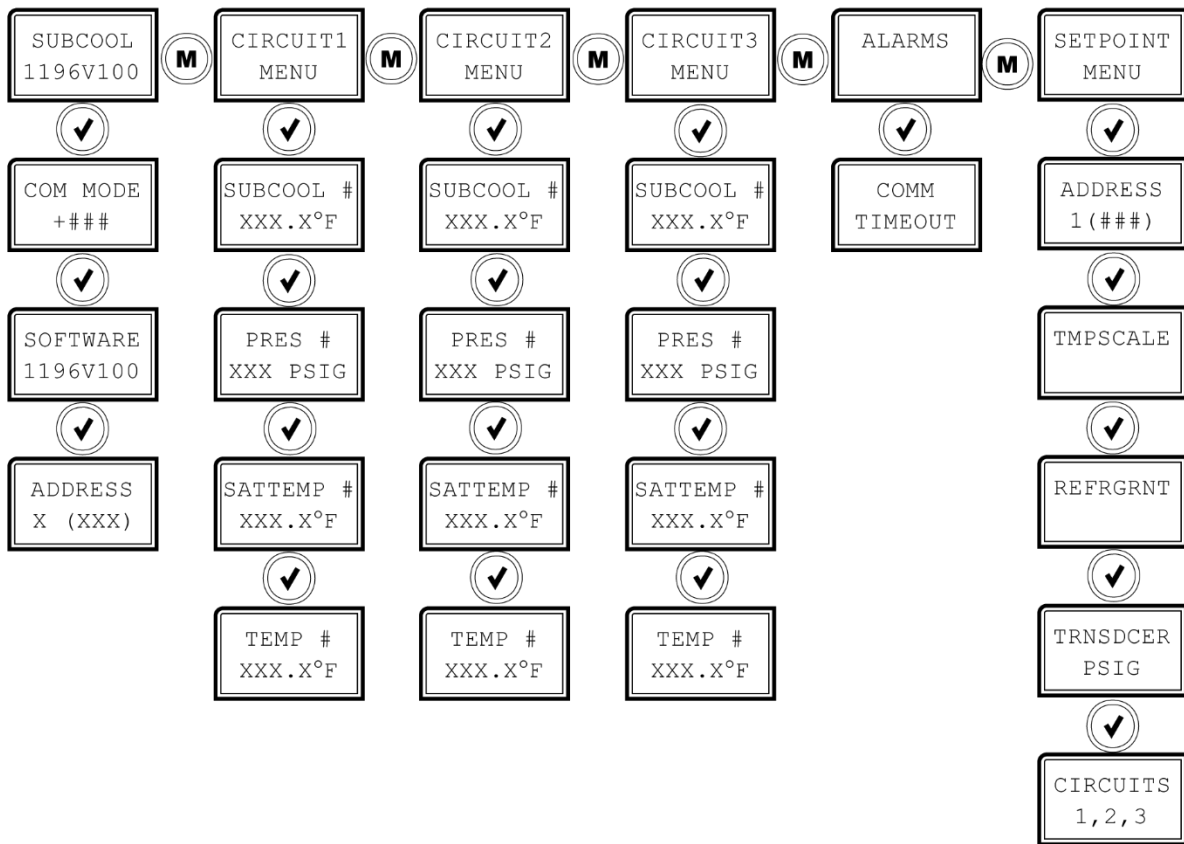

Figure 10: RM454-SC (Subcool Monitor) Screens Map

## 7.7. RM454-SC (Subcool Monitor) Module Screen Descriptions

### 7.7.1. Main Screens

Refer to the following table when navigating through the LCD Main Screens.

Press the <MENU> button to navigate between the top level screens. Press the <ENTER> button to scroll through the next level screens.

Table 15: RM454-Z SC Main Screens

Main Screens	
Screen Text	Description
RM454SC 1196vXXX	RM454-SC home screen.
COM MODE +####	EBUS communications diagnostics. Number of packets received.
SOFTWARE 1196vXXX	Software version installed on this module.
ADDRESS X (XXX)	<p>If there is only one Subcool module, the address needs to be set to 1. If there are two Subcool modules, then board address 1 is for the first 3 circuits and address 2 is for the second 3 circuits.</p> <p>Number in parenthesis is the E-Bus Address.</p> <p>Module 1's address is 169. Module 2's address is 170.</p>

### 7.7.2. Circuits 1, 2, and 3 Status Screens

Refer to the following map when navigating through the Circuit Status Screens. From the CIRCUIT MENU Screen, press <ENTER> to scroll through the screens.

Table 16: RM454-SC Circuit Status Screens

System Status Screens	
Screen Text	Description
CIRCUIT # MENU	Circuit Menu. # represents which circuit current is being viewed.
SUBCOOL # XXX.X°F	Current subcool temperature.
PRESS X XXX PSIG	Liquid line reading from the input.
SATTEMP # XXX.X°F	Saturated liquid temperature.
TEMP # XXX.X°F	Liquid line temperature.

### 7.7.3. Alarms Screens

If an alarm is present, the ALARM LED above the LCD display will light up red and blink. The Alarms will display and scroll automatically from the ALARMS screen when alarms are present.

Table 17: RM454-SC Alarm Screens

Main Screens	
Screen Text	Description
ALARMS	Alarms are present.
NO ALARMS	No alarms are present.
COMM TIMEOUT	This alarm will display if the Subcool Monitor is not communicating with the AAON unit controller.

### 7.7.4. Setpoint Screens

Refer to the following map when navigating through the Setpoint Screens. From the SETPOINT MENU Screen, press <ENTER> to scroll through the screens.

Table 18: RM454-SC Setpoint Screens

System Status Screens	
Screen Text	Descriptions
SETPOINT MENU	Subcool Monitor Setpoint Menu.
ADDRESS X (XXX)	Module address. Valid range 1-4 (EBUS 169-172). Default is 1 (169).
TMPSCALE	Temperature scaling. Fahrenheit or Celsius.
REFRGRNT	Refrigerant type. 454b, 410-A, 134a, or R22.
TRNSDCER PSIG	Transducer PSIG. 250, 500, or 667.
CIRCUITS X	Number of circuits, 1-3.

## 8. APPENDIX A: TROUBLESHOOTING

### 8.1. RM454-Z LED Diagnostic

#### 8.1.1. Using RM454-Z LEDs to Verify Operation

The RM454-Zs are equipped with LEDs that can be used to verify operation and perform troubleshooting. See Figure 11 for the LED locations. The LEDs associated with these inputs and outputs allow you to see what is active without using a voltmeter. The LEDs and their uses are as follows:

**STATUS** - If the software is running, this LED will blink according to what mode the RM454-Z is in. See Table 19 below.

Table 19: Status LED Blink Codes

No. of Blinks	Status LED
1	Off Mode
2	Cool Mode
3	Heat Mode
4	Reheat Mode
5	Force Mode
Fast Blink	Emergency Shutdown

**ALARM (on board and above LCD display)** - This red LED will blink when there is an alarm present. The type of alarm will display on the LCD display. The ALARM LED also blinks when the expansion valve is initializing at startup.

**COMM** - Every time the module receives a valid E-BUS request from the AAON unit controller, this LED will blink on and then off, signifying that it received a valid request and responded.

**POWER** - This LED will light up to indicate that 24 VAC power has been applied to the module.

#### 8.1.2. Binary Input LEDs

**BIN1** - This green LED will light up when the Compressor 1 Status contact is closed.

**BIN2** - This green LED will light up when the Compressor 2 Status contact is closed.

**BIN3** - This green LED will light up when the Oil Level Switch is closed.

**BIN4** - This green LED will light up when the Emergency Shutdown contact is closed.

#### 8.1.3. Relay LEDs

**RLY1 - RLY4** - These green LEDs will light up when the relays are enabled and will stay lit as long as they are active.

#### 8.1.4. RM454-Z Stepper Motor Valve LEDs

**EXV-1** - This yellow LED will blink to indicate communication to the Superheat Controller. If the LED is on solid that indicates no communication to the superheat controller.

**EXV-2** - This yellow LED will blink to indicate communication to the Superheat Controller. If the LED is on solid that indicates no communication to the superheat controller.

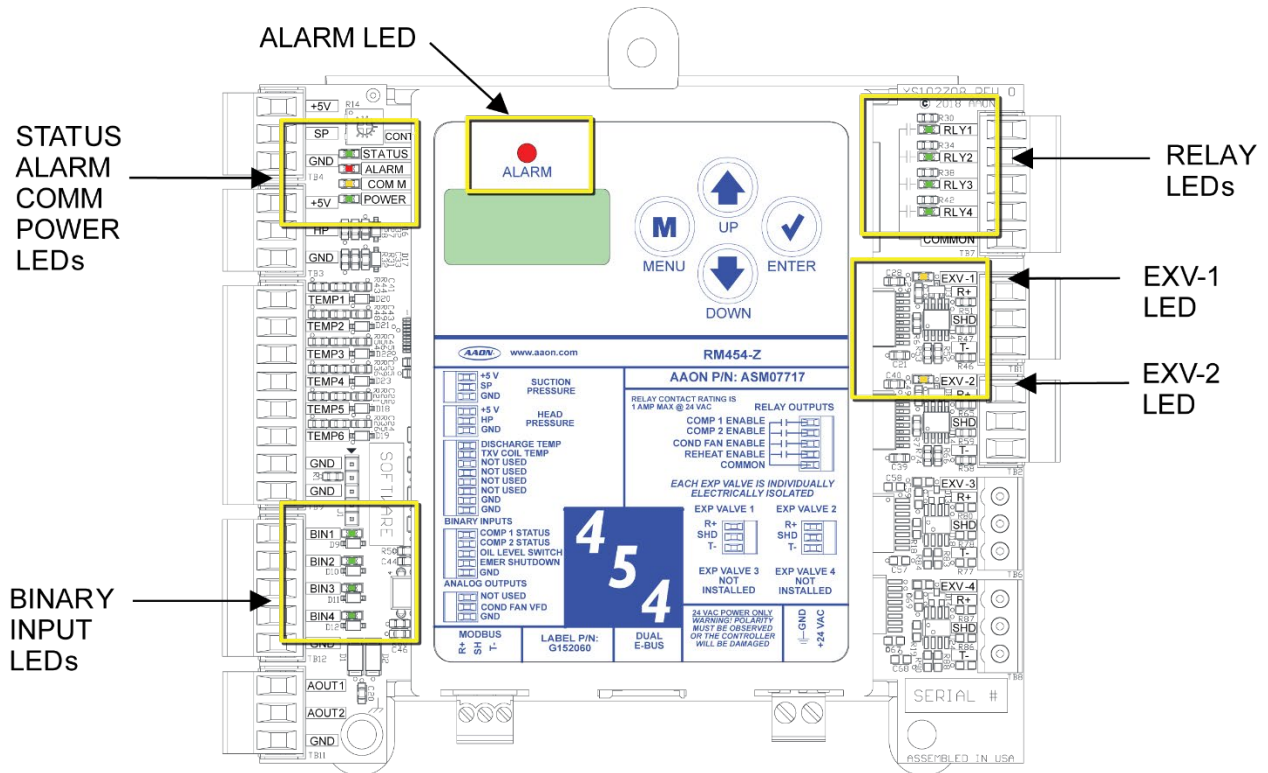

Figure 11: RM454-Z LED Locations

## 8.2. RM454-SC (Subcool Monitor) LED Diagnostics

### 8.2.1. Using RM454-SC LEDs to Verify Operation

The RM454-SC is equipped with LEDs that can be used to verify operation and perform troubleshooting. See Figure 12 below for the LED locations. The LEDs and their uses are as follows:

**POWER** - This LED will light up to indicate that 24 VAC power has been applied to the module.

**COMM** - Every time the module receives a valid E-BUS request from the AAON unit controller, this LED will blink on and then off, signifying that it received a valid request and responded.

**STATUS** - If the software is running, this LED should blink once every 10 seconds.

**ALARM (on board)** - If the module does not receive communications for more than one minute, this LED will blink.

**ALARM (above LCD display)** - This red LED will light up and blink when there is an alarm present. The type of alarm will be displayed on the LCD display.

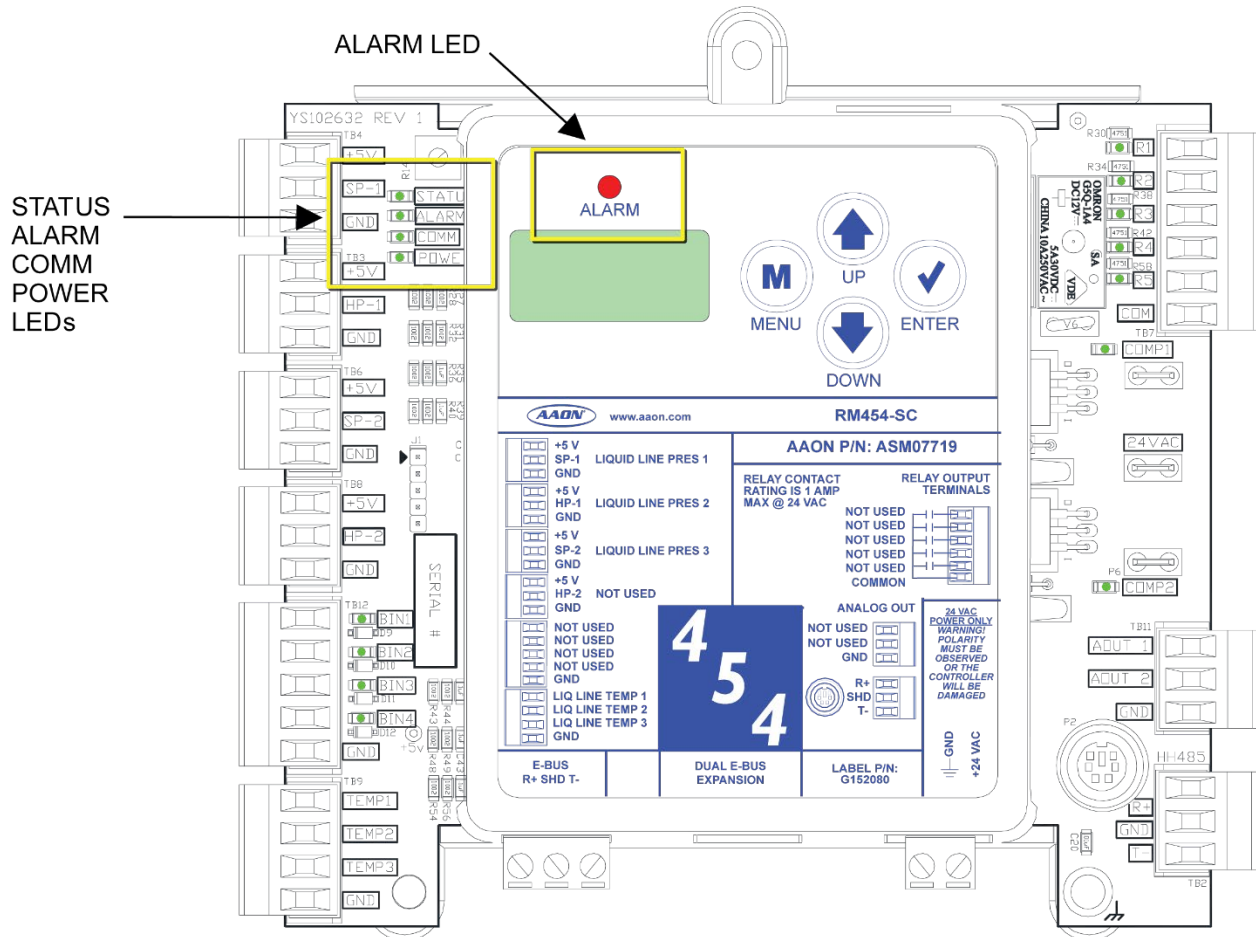

Figure 12: Subcool Monitor LED Locations

## 8.3. Reheat Expansion Module LED Diagnostics

### 8.3.1. LED Diagnostics

The Reheat Expansion Module is equipped with four LEDs that can be used to verify operation and perform troubleshooting.

See Figure 13 for the LED locations. The LEDs associated with these inputs and outputs allow you to see what is active without using a voltmeter. The LEDs and their uses are as follows:

### 8.3.2. Operation LEDs

**POWER** - This green LED will light up to indicate that 24 VAC power has been applied to the Expansion Module.

**STATUS** - This green LED will light up and blink every 10 seconds according to valve position. One blink per 10%. Example: valve position is 67%. STATUS LED will blink six times every 10 second cycle. The STATUS LED will stay on solid during the two-minute flush cycle. See Table 20 below.

Table 20: Reheat Expansion Module Alarm LED Blink Codes

No. of Blinks	Status LED
1-10	Per 10% valve position
Solid	During two-minute flush cycle

### 8.3.3. Communication LED

**COMM** - This amber LED will light up and blink once for every good packet received. Packets should be sent once every second, so the COMM LED should blink the same, once every second. The COMM LED should blink simultaneously on all modules.

### 8.3.4. Binary Input LED

**COMPRESSOR ENABLE** - This green LED will light up when the Reheat is enabled.

### 8.3.5. LED Troubleshooting

**“POWER” LED** - When the Reheat Expansion Module is powered up, the POWER LED should light up and stay on continuously. If it does not light up, check to be sure that the power wiring is connected to the board, the connections are tight, and the transformer is powered. If after making all these checks, the POWER LED does not light up, the board is probably defective.

**“STAT” LED** - When the board is first powered up, the STAT LED will do the following:

- On for 10 seconds
- Blinks 30 times
- Status code repeatedly blinks the indicated valve position every ten seconds

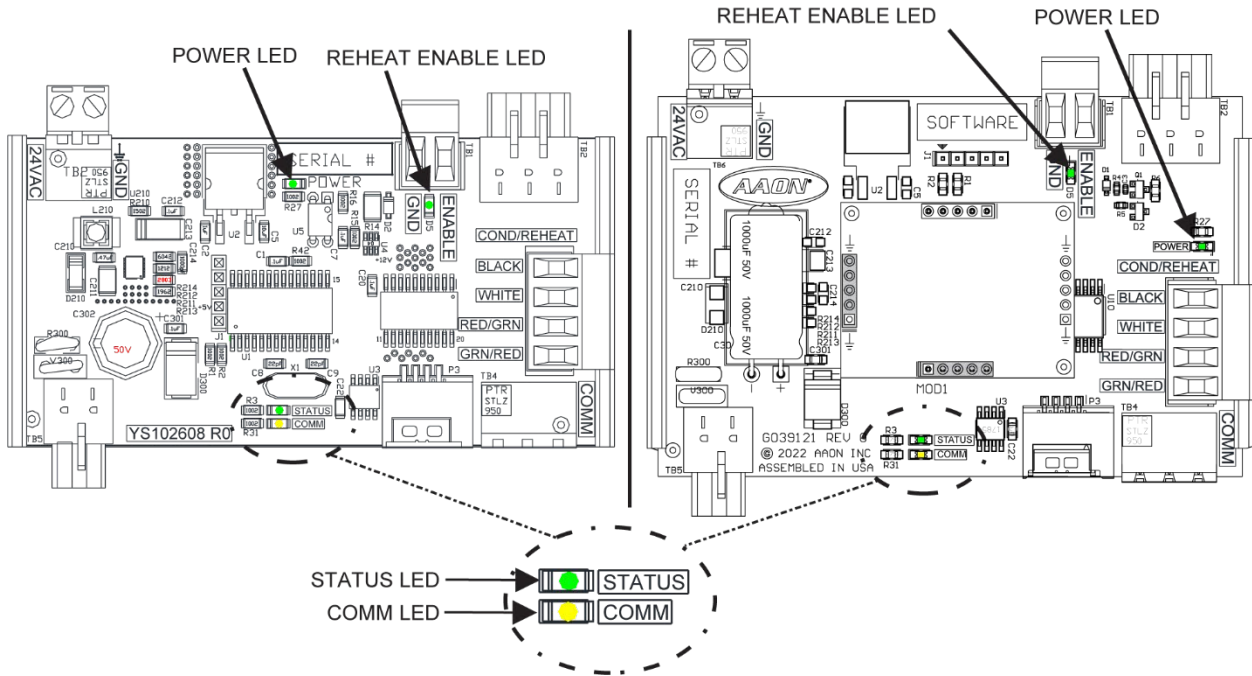

Figure 13: Reheat Expansion LED Locations and Descriptions

## 8.4. Temperature Sensor Testing

### 8.4.1. Sensor voltage and Resistance

The following sensor voltage and resistance table is provided to aid in checking sensors that appear to be operating incorrectly. See Table 21 below. Many system operating problems can be traced to incorrect sensor wiring. Be sure all sensors are wired per the wiring diagrams in this manual.

If the sensors still do not appear to be operating or reading correctly, check the voltage and/or resistance to confirm that the sensor is operating correctly per the table. Please follow the notes and instructions that appear after the chart when checking sensors.

**Note:** If the voltage is above 5.08 VDC, the sensor or wiring is “open.” If the voltage is less than 0.05 VDC, the sensor or wiring is shorted.

Table 21: 0-5V Temperature Sensor - Voltage and Resistance for Type III Sensors

Temperature to Resistance/Voltage Chart							
Temp (°F)	Temp (°C)	Resistance (Ohms)	Voltage @ Input (VDC)	Temp (°F)	Temp (°C)	Resistance (Ohms)	Voltage @ Input (VDC)
-10	-23.3	93333	4.620	72	22.2	11136	2.695
-5	-20.6	80531	4.550	73	22.8	10878	2.665
0	-17.8	69822	4.474	74	23.3	10625	2.635
5	-15	60552	4.390	75	23.9	10398	2.607
10	-12.2	52500	4.297	76	24.4	10158	2.577
15	-9.4	45902	4.200	78	25.6	9711	2.520
20	-6.6	40147	4.095	80	26.7	9302	2.465
25	-3.9	35165	3.982	82	27.8	8893	2.407
30	-1.1	30805	3.862	84	28.9	8514	2.352
35	1.7	27140	3.737	86	30	8153	2.297
40	4.4	23874	3.605	88	31.1	7805	2.242
45	7.2	21094	3.470	90	32.2	7472	2.187
50	10	18655	3.330	95	35	6716	2.055
52	11.1	17799	3.275	100	37.8	6047	1.927
54	12.2	16956	3.217	105	40.6	5453	1.805
56	13.3	16164	3.160	110	43.3	4923	1.687
58	14.4	15385	3.100	115	46.1	4449	1.575
60	15.6	14681	3.042	120	48.9	4030	1.469
62	16.7	14014	2.985	125	51.7	3656	1.369
64	17.8	13382	2.927	130	54.4	3317	1.274
66	18.9	12758	2.867	135	57.2	3015	1.185
68	20	12191	2.810	140	60	2743	1.101
69	20.6	11906	2.780	145	62.7	2502	1.024
70	21.1	11652	2.752	150	65.6	2288	0.952
71	21.7	11379	2.722				

## 8.5. Suction Pressure Transducer Testing

### 8.5.1. Suction Pressure Transducer Testing for R454-B refrigerant

The evaporator coil temperature is calculated by converting the suction pressure to temperature. The suction pressure is obtained by using the Suction Pressure Transducer, which is connected to the suction line of the compressor.

Use the voltage column to check the Suction Pressure Transducer while connected to the RM454-Z Module. The VCCX-454 and the RM454-Z Module must be powered for this test. Read the voltage with a meter set on DC volts. Place the positive lead from the meter on the SP1/SP2 terminal located on the RM454-Z Module terminal block. Place the negative lead from the meter on the ground (GND) terminal located adjacent to the SP1/SP2 terminal on the RM454-Z Module terminal block. Use a refrigerant gauge set and/or an accurate electronic thermometer to measure the temperature or suction line pressure near where the Suction Pressure Transducer is connected to the suction line. Measure the voltage at the SP1/SP2 and GND terminals and compare it to the appropriate chart depending on the refrigerant in use. If the temperature/voltage or pressure/voltage readings do not align closely with the chart, the Suction Pressure Transducer is probably defective and needs to be replaced.

See Table 22 to the right. The chart shows a temperature range from 25.88°F to 86.11°F. For troubleshooting purposes, the DC voltage readings are also listed with their corresponding temperatures and pressures.

Table 22: Suction Pressure Transducer Chart for R454-B Refrigerant (Vapor)

Suction Pressure Transducer Coil Pressure Temperature and Voltage Chart For R454 Refrigerant			
Temperature (°F)	Temperature (°C)	Pressure (psi)	Signal DC Volts
<b>25.88</b>	-3.4	80.94	1.8
<b>29.42</b>	-1.4	87.16	1.9
<b>32.81</b>	0.5	93.39	2.0
<b>36.05</b>	2.6	99.62	2.1
<b>39.16</b>	4.0	105.84	2.2
<b>42.15</b>	5.6	112.07	2.3
<b>45.02</b>	7.2	118.29	2.4
<b>47.79</b>	8.8	124.52	2.5
<b>50.47</b>	10.3	130.75	2.6
<b>53.06</b>	11.7	136.97	2.7
<b>55.57</b>	13.1	143.20	2.8
<b>57.99</b>	14.4	149.42	2.9
<b>60.36</b>	15.8	155.65	3.0
<b>62.65</b>	17.0	161.88	3.1
<b>64.88</b>	18.3	168.10	3.2
<b>67.05</b>	19.5	174.32	3.3
<b>69.16</b>	20.6	180.55	3.4
<b>71.23</b>	21.8	186.78	3.5
<b>73.24</b>	22.9	193.00	3.6
<b>75.20</b>	24.0	199.23	3.7
<b>77.12</b>	25.1	205.46	3.8
<b>79.00</b>	26.1	211.68	3.9
<b>80.83</b>	27.1	217.91	4.0
<b>82.63</b>	28.1	224.14	4.1
<b>84.39</b>	29.1	230.36	4.2
<b>86.11</b>	30.1	236.59	4.3

## 8.6. Liquid Line and Head Pressure Transducer

### 8.6.1. Liquid Line Pressure Transducer and Head Pressure Transducer Testing 0-667 psi

#### Liquid Line Pressure Transducer Testing

The Liquid Line Pressure is obtained from the Liquid Line Pressure Transducer, which is connected to the compressor's Liquid Line.

Use the voltage column to check the Liquid Line Pressure Transducer while connected to the Subcool Monitor Module. The module must be powered for this test. Read the voltage with a meter set on DC volts. Place the positive lead from the meter on the SIG input terminal located on the module. Place the negative lead from the meter on the ground (GND) terminal located adjacent to the SIG terminal on the module. Use a refrigerant gauge set to measure the suction line pressure near where the Liquid Line Pressure Transducer is connected to the discharge line. Measure the voltage at the SIG and GND terminals and compare it to the appropriate chart depending on the refrigerant you are using. If the pressure/voltage readings do not align closely with the chart, your Liquid Line Pressure Transducer is probably defective and will need to be replaced.

#### Head Pressure Transducer Testing

Use the voltage column to check the Head Pressure Transducer while connected to the RM454-Z Module. The module must be powered for this test. Read the voltage with a meter set on DC volts. Place the positive lead from the meter on the HP input terminal located on the module. Place the negative lead from the meter on the ground (GND) terminal located adjacent to the HP terminal on the module. Use a refrigerant gauge set to measure the line pressure near where the Head Pressure Transducer is connected to the condenser.

Measure the voltage at the HP and GND terminals and compare it to the appropriate chart depending on the refrigerant you are using. If the pressure/voltage readings do not align closely with the chart, your Head Pressure Transducer is probably defective and will need to be replaced.

Table 23: 0-667 psi Transducer Chart

0-667 psi Transducer Chart			
Voltage	Pressure	Voltage	Pressure
0.5	0	2.6	350
0.6	17	2.7	367
0.7	33	2.8	384
0.8	50	2.9	400
0.9	67	3.0	417
1.0	83	3.1	434
1.1	100	3.2	450
1.2	117	3.3	467
1.3	133	3.4	484
1.4	150	3.5	500
1.5	167	3.6	517
1.6	183	3.7	534
1.7	200	3.8	550
1.8	217	3.9	567
1.9	233	4.0	584
2.0	250	4.1	600
2.1	267	4.2	617
2.2	283	4.3	634
2.3	300	4.4	650
2.4	317	4.5	667
2.5	334		

## 9. APPENDIX B: DANFOSS VFD

### 9.1. Parameter Configurations

Table 24: Danfoss VFD Parameter Configurations

Danfoss CDS803 and CDS303 Parameter Setup			
Parameter	Name	Value to Set	Value Description
1-00	Configuration Mode	0	Speed Open Loop
1-13	Compressor Selection	TBD	Based on Compressor Model connected
3-10	Preset Reference	0	Must remain zero for open loop
3-14	Preset Relative Ref	0	Fixed value added to variable value
3-15	Reference Resource 1	11	Local Bus Reference
3-16	Reference Resource 2	0	No Function
3-17	Reference Resource 3	0	No Function
8-01	Control Site	2	Control word only
8-02	Control Word source	1	FC Port RS-485
8-03	Control Timeout	20	20 second timeout
8-04	Control Word T/O Function	5	Stop and Trip
28-10	Oil System Recovery	0	Disable Built-in Oil Boost
8-30	Protocol	2	Modbus RTU
8-31	Address	1	Modbus Address (1 = default)
8-32	Baud Rate	3	19200 Baud
8-33	Parity / Stop bit	0	Even Parity / 1 Stop bit
Additional CDS803 Parameters			
3-00	Reference Range	0	Min - Max
3-13	Reference Site	1	Remote
0-20	Motor Speed Unit	0	RPM (vs. Hz)

Key	
	Blue = User must configure from the display
	Yellow = Set through communications once communications are established
	Green = Default, but confirm if not working

# 10. APPENDIX C: SYSTEM CONFIGURATION

## 10.1. Module and Condenser Configuration in Prism 2

### 10.1.1. RM454-Z Module Configuration

In Prism 2's "Configuration 1 Page", select the radio button for "Check this box for RM454-Z modules", select the radio button for "3 Circuit 1 Sub-Cool" or "6 Circuit 2 Sub-Cool", and then select the check box for "RM454-Z Has Sub-Cooling Module" if you are using it. See Figure 14 below.

Figure 14: RM454-Z Module Configuration

### 10.1.2. RM454-Z Condenser Configuration

Select Prism 2's RM454-Z module tab selection. In a "Single Condenser Per Module" wiring configuration, the Condenser Signal is wired to A02, and the Condenser Relay (RLY3) is enabled. See Figure 15 below.

Figure 15: Prism 2 RM454-Z Configuration Page

### 10.1.2.1. Emergency Shutdown

If the emergency shutdown input is being used on the first module, this configuration will need to be selected.

Figure 16: Configuration of Emergency Shutdown Input

### 10.1.2.2. Low Ambient Kits Installed On:

If low ambient kits are installed on the unit, select which circuits they are installed on.

Figure 17: Low Ambient Kits Installation Options

### 10.1.2.3. Condenser Configuration

If each module controls the condenser fans for its circuit, only select Standard Condenser Per Module. If there is a single condenser control for the variable circuits and the tandem circuits have their own, then select Single Condenser for A & B. If there is a single condenser control for the system, then select Single Condenser for the system.

The screenshot shows the 'RSMZ Configuration' window with four main sections:

- Configuration:** Includes 'Emergency Shutdown Input' (checkbox), 'Unit Tonnage' (0), and 'Max Reheat Valve Position' (0%).
- Modulating HPC Setpoint:** Includes 'Air to Air Heat Pumps and Standard Units' with 'Cooling Mode Head Pressure' (0 PSI) and 'Reheat Mode Head Pressure' (0 PSI).
- Low Ambient Kits Installed On:** Radio buttons for 'None' (selected), 'All Circuits', 'Digital Circuits', and 'On/Off Circuits'.
- Condenser Configuration:** Radio buttons for 'Standard Condenser Per Module' (selected), 'Single Condenser for A & B', and 'Single Condenser for the system'. This section is highlighted with a yellow border.
- Low Load Configuration:** Includes 'Stage Half of the VFDs' (checkbox) and 'Low Load Stage Up Percentage' (0%).

Figure 18: Condenser Configuration Options

### 10.1.2.5. Low Load Configuration

When Stage Half of the VFDs is selected, the unit will only turn on half of the VFD circuits at startup instead of all of them. Once the VFD percentage reaches the Low Load Stage Up Percentage, the other VFD compressor will activate.

The screenshot shows the 'RSMZ Configuration' window with four main sections:

- Configuration:** Includes 'Emergency Shutdown Input' (checkbox), 'Unit Tonnage' (0), and 'Max Reheat Valve Position' (0%).
- Modulating HPC Setpoint:** Includes 'Air to Air Heat Pumps and Standard Units' with 'Cooling Mode Head Pressure' (0 PSI) and 'Reheat Mode Head Pressure' (0 PSI).
- Low Ambient Kits Installed On:** Radio buttons for 'None' (selected), 'All Circuits', 'Digital Circuits', and 'On/Off Circuits'.
- Condenser Configuration:** Radio buttons for 'Standard Condenser Per Module' (selected), 'Single Condenser for A & B', and 'Single Condenser for the system'.
- Low Load Configuration:** Includes 'Stage Half of the VFDs' (checkbox) and 'Low Load Stage Up Percentage' (0%). This section is highlighted with a yellow border.

Figure 20: Low Load Configuration Options

### 10.1.2.4. Modulating HPC Setpoint

Enter the head pressure setpoints used for cooling and dehumidification modes.

The screenshot shows the 'RSMZ Configuration' window with four main sections:

- Configuration:** Includes 'Emergency Shutdown Input' (checkbox), 'Unit Tonnage' (0), and 'Max Reheat Valve Position' (0%).
- Modulating HPC Setpoint:** Includes 'Air to Air Heat Pumps and Standard Units' with 'Cooling Mode Head Pressure' (0 PSI) and 'Reheat Mode Head Pressure' (0 PSI). This section is highlighted with a yellow border.
- Low Ambient Kits Installed On:** Radio buttons for 'None' (selected), 'All Circuits', 'Digital Circuits', and 'On/Off Circuits'.
- Condenser Configuration:** Radio buttons for 'Standard Condenser Per Module' (selected), 'Single Condenser for A & B', and 'Single Condenser for the system'.
- Low Load Configuration:** Includes 'Stage Half of the VFDs' (checkbox) and 'Low Load Stage Up Percentage' (0%).

Figure 19: Modulating HPC Setpoint Options



## 11. REVISION HISTORY

RM454-Z Controller Technical Guide Change Log	
Revision and Date	Change
Rev. A, September 27, 2024	Initial Release
Rev. B, December 17, 2024	Updated Suction Pressure Transducer Chart
Rev. C, December 30, 2024	Update to Parts Reference, Subcooling Sequencing, and Tables and Figures
Rev. D, March 28, 2025	Updated Main Screens: 6-Module Address screen
Rev. E, April 23, 2026	Updated Document Formatting and the RM454-Z Module Configuration Figure



AAON Controls Support:

Support.Controls@aaon.com

Controls Support Website:

[www.aaon.com/aaon-controls-technical-support](http://www.aaon.com/aaon-controls-technical-support)

AAON Factory Technical Support:

Technical.Support@aaon.com

Phone:

866-918-1100

Monday through Friday, 7:00 AM to 5:00 PM Central Time

Before calling Technical Support, have the model and serial number of the unit available.

For replacement parts, contact your local AAON Representative.

**Are you an AAON Rep?** Visit My AAON to open new support tickets, communicate directly with our support teams, and track your support progress in one place.

It is the intent of AAON to provide accurate and current product information. However, in the interest of product improvement, AAON reserves the right to change pricing, specifications, and/or design of its product without notice, obligation, or liability.

AAON® is a registered trademark of AAON, Inc., Tulsa, OK. BACnet® is a registered trademark of ASHRAE Inc., Atlanta, GA. BITZER is a registered trademark of BITZER® Kühlmaschinenbau GmbH. Copeland Scroll™ is a registered trademark of Emerson Electric Co., Saint Louis, MO.

Copyright © AAON, all rights reserved throughout the world.

AAON® is a registered trademark of AAON, Inc., Tulsa, OK. AAON® assumes no responsibility for errors or omissions in this document.

This document is subject to change without notice.