

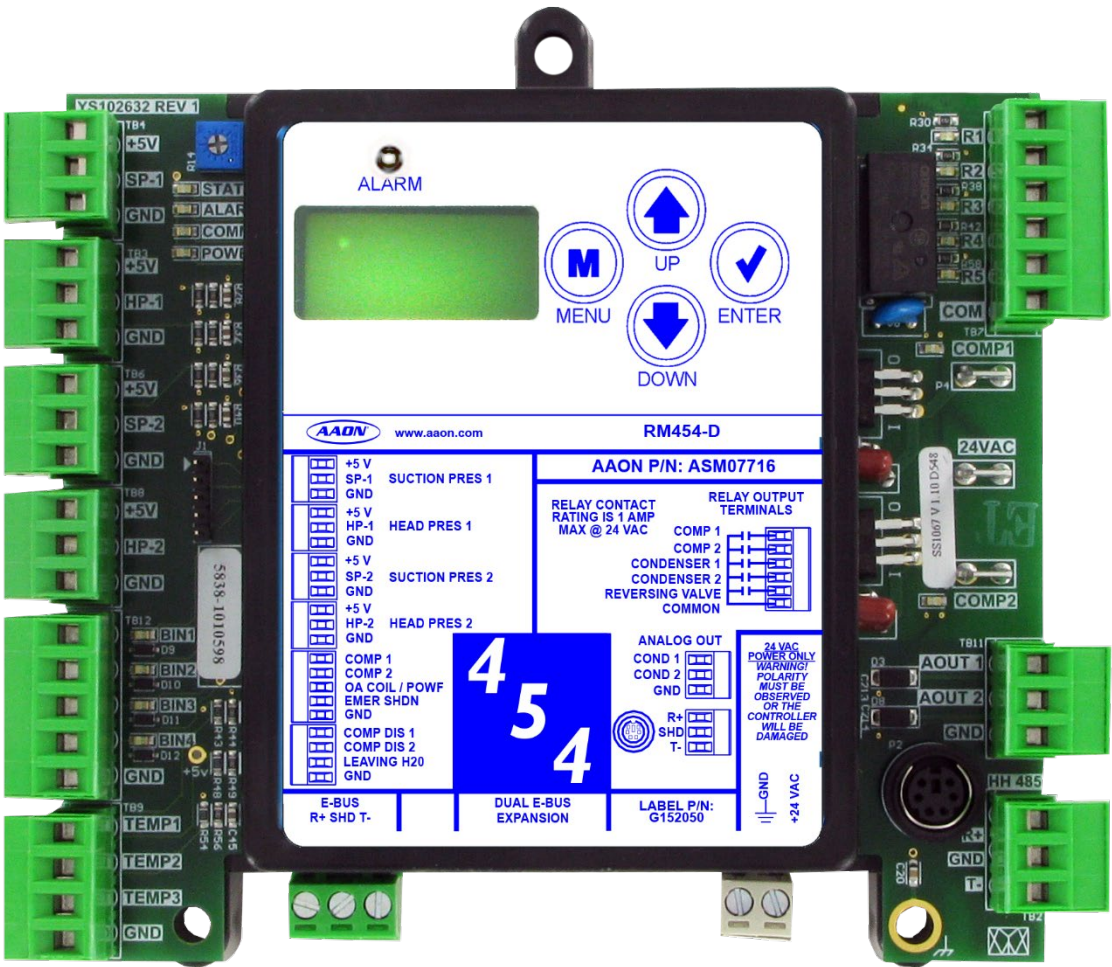

Compatible with
VCCX-454
Series

RM454-D Module Technical Guide

ASM07716
Software SS1193





PRODUCT NAME PARTS REFERENCE

Table 1: Product Name Parts Reference

Product Name Parts Reference	
Part Description	Part Number
Software for RM454-D	SS1193
VCCX-454 Controller	ASM07503
Prism 2	ASM02533
IP Module Kit	ASM01902
CommLink 6	ASM07420
EBC E-Bus Cable Assembly E-BUS Power & Comm 1.5 Ft, 3 Ft, 10 Ft, 25 Ft, 50 Ft, 75 Ft, 100 Ft, 150 Ft, 250 ft, and 1000 Foot Spool	G029440 (1.5 Ft), G012879 (3 Ft), G029460 (10 Ft), G045270 (25 Ft), G029510 (50 Ft), G029450 (100 Ft), G029470 (150 Ft), V36590 (250 Ft), G018870 (SPOOL)



TABLE OF CONTENTS

1. NOTES, CAUTIONS, AND WARNINGS	6
2. OVERVIEW.....	7
2.1. General Information.....	7
2.2. Dimensions	8
3. INSTALLATION AND WIRING	9
3.1. Electric and Environmental Requirements	9
4. WIRING	11
4.1. Inputs Wiring	11
4.2. Outputs Wiring.....	12
5. INPUTS AND OUTPUTS	13
5.1. Map	13
5.2. RM454-D Inputs and Outputs.....	14
6. SEQUENCE OF OPERATIONS.....	16
6.1. Prism 2 Configuration	16
6.2. Mode of Operation.....	17
6.3. Staging	18
6.4. Envelope Protection.....	26
7. LCD SCREENS	27
7.1. Display Screen and Navigation Keys	27
7.2. Screens Map	28
7.3. Screen Descriptions.....	29
7.4. Alarm Screens	32
7.5. Protected Screens.....	35
7.6. Diagnostic Screens	36
7.7. Address Screen	38
8. TROUBLESHOOTING.....	39
8.1. LED Diagnostics.....	39
8.2. Suction Pressure Transducer Testing	41
8.3. Temperature Sensor Testing.....	42
8.4. Head Pressure Transducer	44
9. REVISION HISTORY	45



TABLE OF FIGURES

Figure 1: RM454-D Dimensions.....	8
Figure 2: RM454-D Inputs Wiring.....	11
Figure 3: RM454-D Outputs Wiring.....	12
Figure 4: Prism 2 RM454-D Configuration Screen	16
Figure 5: Prism 2 RM454-D Configuration Options	16
Figure 6: Copeland YAS67K1-91K1 and R454 Envelope	26
Figure 7: Copeland YAD98-115 Envelope.....	26
Figure 8: LCD Display and Navigation Keys.....	27
Figure 9: LCD Screens Map	28
Figure 10: Protected Screens Map	35
Figure 11: Diagnostic Screens Map	36
Figure 12: RM454-D LED Locations.....	40



TABLE OF TABLES

Table 1: Product Name Parts Reference i

Table 2: Electrical and Environmental Requirements 9

Table 3: RM454-D Inputs and Outputs 13

Table 4: Staging - RM454-D 1 Circuit: Digital Cooling States 18

Table 5: Staging - 2 RM454-D 2 Circuit: Digital, On/Off + On/Off Cooling States 18

Table 6: Staging - 2 RM454-D 2 Circuit: Digital, On/Off + On/Off Reheat States 18

Table 7: 2 RM454-D 2 Circuit: Digital + On/Off, Digital + On/Off Cooling States 18

Table 8: Staging - 2 RM454-D 2 Circuit: Digital + On/Off + On/Off Cooling States 19

Table 9: Staging - 2 RM454-D 2 Circuit: Digital + On/Off, On/Off + On/Off Reheat States 19

Table 10: Staging - 2 RM454-D 4 Circuit: Digital, Digital, 2-Step, 2-Step RNA-D Units Cooling States 19

Table 11: Staging - 2 RM454-D 4 Circuit: Digital, Digital, 2-Step, 2-Step RNA-D Units Reheat States 19

Table 12: Staging - RM454-D 2 Circuit: Digital, 2-Step Cooling States 20

Table 13: Staging - 1 RM454-D 2 Circuit: Digital, 2-Step Reheat States 20

Table 14: Staging - 1 RM454-D 2 Circuit: Digital, On/Off Cooling States 20

Table 15: Staging - 1 RM454-D 2 Circuit: Digital, On/Off Reheat States 20

Table 16: Staging - 2 RM454-D 4 Circuit: Digital, On/Off, Digital, On/Off Cooling States 20

Table 17: Staging - 2 RM454-D 4 Circuit: Digital, On/Off, Digital, On/Off Reheat States 20

Table 18: Staging - 2 RM454-D 2 Circuit: Digital, Digital Cooling States 21

Table 19: Staging - 2 RM454-D 2 Circuit: Digital, Digital Reheat States 21

Table 20: Staging - 1 RM454-D 2 Circuit: Digital, Digital Cooling States 21

Table 21: Staging - 1 RM454-D 2 Circuit: Digital, Digital Reheat States 21

Table 22: Staging - 2 RM454-D 4 Circuit: Digital, 2-Step, Digital 2-Step CF 20-ton Units and SA 70-ton Units Cooling States.. 21

Table 23: Staging - 2 RM454-D 4 Circuit: Digital, 2-Step, Digital, 2-Step CF 20-ton Units and SA 70-ton Units Reheat States.. 21

Table 24: Staging - 2 RM454-D 2 Circuit: On/Off + On/Off, On/Off + On/Off Cooling States 22

Table 25: Staging - 2 RM454-D 2 Circuit: On/Off + On/Off, On/Off+ On/Off Reheat States 22

Table 26: Staging - 1 RM454-D 2 Circuit On/Off + On/Off Cooling States 22

Table 27: Staging - 1 RM454-D 2 Circuit: On/Off + On/Off Cooling States 22

Table 28: Staging - 2 RM454-D 2 Circuit: On/Off, On/Off Cooling States 22

Table 29: Staging - 1 RM454-D 1 Circuit: 2-Step Cooling States 22

Table 30: Staging - 1 RM454-D 2 Circuit: 2-Step, 2-Step Cooling States 23

Table 31: Staging - RM454-D 2 Circuit: 2-Step, 2-Step Reheat States 23

Table 32: Staging - 2 RM454-D 4 Circuit: 2-Step, 2-Step, 2-Step, 2-Step Cooling States 23

Table 33: Staging - 2 RM454-D 4 Circuit: 2-Step, 2-Step, 2-Step, 2-Step Reheat States 23

Table 34: Staging - 2 RM454-D 2 Circuit: 2-Step, 2-Step Cooling States 23

Table 35: Staging - 2 RM454-D 2 Circuit: 2-Ste[, 2-Step Reheat States 24



Table 36: Staging - 4 RM454-D 4 Circuit: 2-Step, 2-Step, 2-Step, 2-Step Cooling States 24

Table 37: Staging - 4 RM454-D 4 Circuit: 2-Step, 2-Step, 2-Step, 2-Step Reheat States 24

Table 38: Staging - 2 RM454-D 4 Circuit: 2-Step, 2-Step, 2-Step, 2-Step Cooling States 24

Table 39: Staging - 2 RM454-D 4 Circuit: 2-Step, 2-Step, 2-Step, 2-Step Reheat States 24

Table 40: Staging - 2 RM454-D 2 Circuit: Tandem Fixed, Fixed, Tandem Fixed, Fixed Cooling States..... 25

Table 41: Staging - 2 RM454-D 4 Circuit; Tandem Digital, Fixed, Tandem Fixed, Fixed Cooling States 25

Table 42: Navigation Key Functions..... 27

Table 43: Main Screens 29

Table 44: Module Screens..... 30

Table 45: System Status Screens..... 30

Table 46: Sensor Status Screens 31

Table 47: Setpoint Status Screens 31

Table 48: Alarm Screens 32

Table 49: Alarm History..... 34

Table 50: Diagnostic Screens 37

Table 51: Coil Pressure/Voltage/Temp for Suction Pressure Transducers - R454 Refrigerant 41

Table 52: Discharge Thermistor Temperature/Resistance..... 42

Table 53: 0-5V Temperature Sensor - Voltage & Resistance for Type III Sensors 43

Table 54: Head Pressure Transducer Chart 44

1. NOTES, CAUTIONS, AND WARNINGS

Note: Notes are intended to clarify the unit installation, operation, and maintenance.

CAUTION

Caution statements are given to prevent actions that may result in equipment damage, property damage, or personal injury.

WARNING

Warning statements are given to prevent actions that could result in equipment damage, property damage, or serious personal injury.

DANGER

Danger statements are given to prevent actions that will result in equipment destruction, property damage, and severe personal injury or death.

2. OVERVIEW

2.1. General Information

2.1.1. Overview

The Refrigerant System Module for Digital Compressors (RM454-D) can monitor and control up to two compressors and condensers. The compressors can be in either a tandem or non-tandem configuration. The module is designed for R454 refrigerant.

The RM454-D is for units that match all of the following criteria:

- One or two circuits;
- Compressors may be any mix of fixed, two-step, and digital;
- Reheat is present on the first circuit

The RM454-D is connected to the VCCX-454 Controller. Up to four RM454-D Modules can be connected, depending on the size of the system. There are two E-BUS expansion ports, which allow the use of communicating sensors and E-BUS modules.

The RM454-D provides seven analog inputs, four binary inputs, five relays, and two analog outputs. See Figure 2, page 11, and Figure 3, page 12, for wiring.



WARNING

The correct Software versions must be used for all software upgrades. Loading the incorrect software could result in malfunction. Contact AAON Technical Support for assistance, if required.

2.1.2. Features

The RM454-D Module:

- Modulates the compressors to satisfy the suction coil (saturated) temperature. The Suction Coil (Saturated) Temperature Setpoint is reset by the VCCX-454 Controller to maintain the supply air temperature during Cooling Mode. During Dehumidification Mode, it controls the compressors to directly maintain the Suction (Saturated) Temperature Setpoint.
- Modulates and stages the compressors to maintain a given Supply Air Temperature Setpoint when the heat pump is in Heating Mode.
- Modulates the condenser fans or valves to maintain the Head Pressure Setpoint.
- Provides alarms and safeties for the compressor and condenser operation.
- Allows the connection of the USB Link to the module when the required communication wire is run to the VCCX-454 Controller.
- Uses an integrated 2 x 8 LCD character display and four navigation buttons to show the status of system operation, system setpoints, system configurations, sensors, and alarms.

2.2. Dimensions

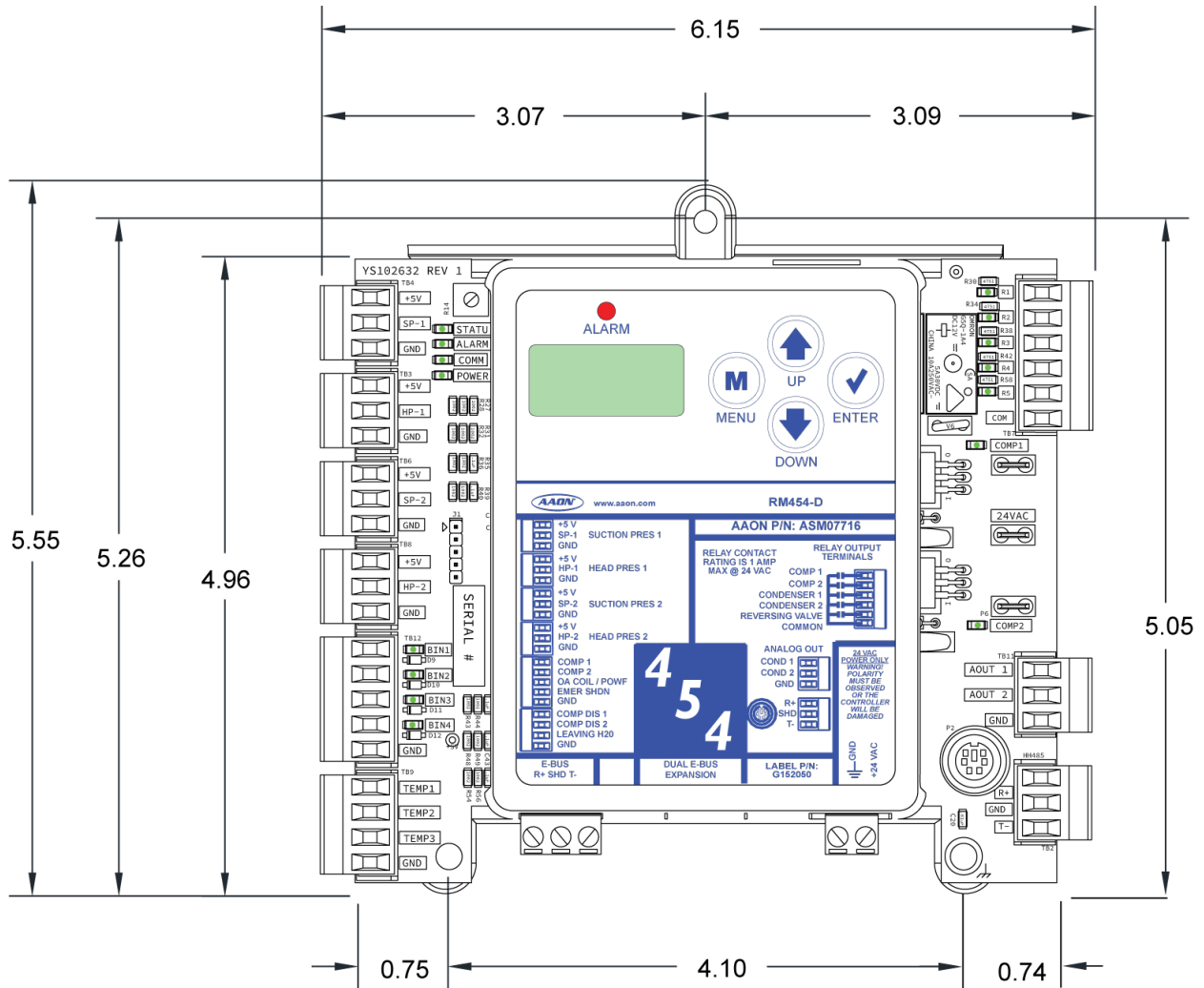

NOTE: All dimensions are in inches.

Figure 1: RM454-D Dimensions

3. INSTALLATION AND WIRING

3.1. Electric and Environmental Requirements

3.1.1. General

Correct wiring of the AAON unit controller and its modules is the most important factor in the overall success of the controller installation process. The AAON unit controller and modules are factory-installed and wired at the AAON factory. Some of the following information may not apply if the system was pre-wired at the factory. However, if troubleshooting of the controller or modules is required, it is a good idea to be familiar with the system wiring.

3.1.2. Wiring

The modules must be connected to an 18-30 VAC power source of the proper size for the calculated VA load requirements. All transformer sizing should be based on the VA ratings listed in Table 2 below.

Table 2: Electrical and Environmental Requirements

Electrical and Environmental Requirements				
Control Device	Voltage	VA Load	Operating Temperature	Humidity (Non-Condensing)
RM454-D Module	18-30 VAC	18	-22°F to 158°F -30°C to 70°C	0-95% RH
	Inputs		Resistive Inputs require 10KΩ Type 3 Thermistor	
	Outputs		24 VAC Inputs provide 4.7kΩ Load Relay Outputs: 1 Amp maximum per output.	

Note: If the temperature at the controller is below -4°F (-20°C), the display refresh rate could be less responsive.



WARNING

When using a single transformer to power more than one controller or expansion module, the correct polarity must always be maintained between the boards. Failure to observe correct polarity will result in damage to the unit controller, RM454-D, and any associated module.

Wiring (Continued)

Please carefully read and apply the following information when wiring the unit controller, RM454-D, and any associated module.

- All wiring is to be in accordance with local and national electrical codes and specifications.
- All 24 VAC wiring must be connected so all ground wires remain common. Failure to follow this procedure can result in damage to the controller and connected devices.
- Minimum wire size for 24 VAC wiring is 18-gauge.
- Minimum wire size for all sensors is 24-gauge. Some sensors require a two-conductor wire, and some require a three- or four-conductor wire.
- Minimum wire size for 24 VAC thermostat wiring is 22-gauge.
- Verify all wiring connections are properly inserted and tightened into the terminal blocks. Do not allow wire strands to stick out and touch the adjoining terminals, which could cause a short circuit.
- When communication wiring is used to connect AAON unit controllers together, or to connect to other communication devices, all wiring must be plenum-rated, minimum 18-gauge, two-conductor, twisted pair with shield. AAON can supply a communication wire that meets this specification and is color coded for the network or local loop. Please consult an AAON distributor for more information. If desired, Belden #82760 or equivalent wire may also be used.
- Recheck all wiring connections and terminations before applying power to the AAON unit controller, RM454-D Modules, and any associated modules.

3.1.3. Powering Up

When the controller and modules are first powered up, the POWER LED should light up and stay on continuously. If it does not light up, verify that the 24 VAC is connected to the controller, the wiring connections are tight, and they are wired for the correct polarity. The 24 VAC power must be connected so all ground wires remain common. If after making all these checks, the POWER LED still does not light up, please contact AAON Controls Support for assistance.

4. WIRING

4.1. Inputs Wiring

4.1.1. Wiring Overview

The RM454-D provides three analog inputs, four binary inputs, five relays, and two analog outputs. See Figure 2, this page for inputs wiring and Figure 3, page 12 for outputs wiring.

WARNING

Observe Polarity! All boards must be wired with GND-to-GND and 24-VAC-to-24 VAC. Failure to observe polarity will result in damage to one or more of the boards. Expansion modules must be wired in such a way that the expansion modules and the controller are always powered together. Loss of power to the expansion module will cause the controller to become inoperative until power is restored to the expansion module.

4.1.2. Suction Pressure Transducer Wiring

The Suction Pressure Transducers must be wired as shown in Figure 2 below. It is typically required for all VCCX-454 applications.

The Suction Pressure Transducers are used to measure suction pressure at the HVAC unit's DX evaporator coil suction line. This suction line pressure is converted to saturated refrigerant temperature. The saturated refrigerant temperature is used to properly control the compressors to maintain a given Suction Coil (Saturated) Temperature Setpoint. In Cooling Mode, the VCCX-454 resets the Suction Coil (Saturated) Temperature Setpoint to maintain a given Supply Air Temperature Setpoint. In Dehumidification Mode, the Suction Coil (Saturated) Temperature Setpoint is a user configurable setpoint that can be reset based on indoor humidity levels.

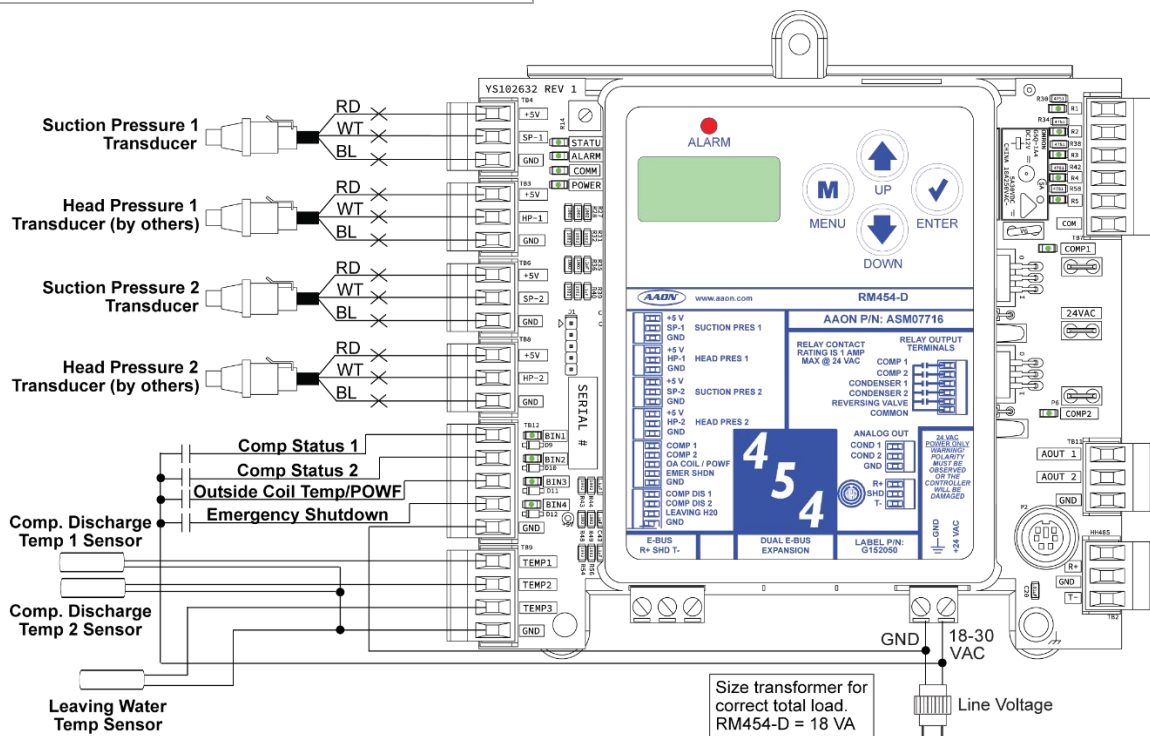

Figure 2: RM454-D Inputs Wiring

4.2. Outputs Wiring

4.2.1. Head Pressure Control

The Head Pressure Transducers are used to measure head pressure at the discharge line. This head pressure is used to drive the condenser fans with a 0-10 VDC output signal to maintain a given Head Pressure Setpoint.

4.2.2. Compressor Discharge Sensors

The Digital Compressor Discharge Temperature Sensor monitors the discharge temperature from the digital compressor to protect against overheating.

4.2.3. Leaving Water Temperature Sensor

The Leaving Water Temperature Sensor is used to measure the leaving water temperature when used on a WSHP unit.



CAUTION

When installing the suction pressure transducer, the Shraeder port should be located in a vertical position of the suction line to prevent refrigerant oil from accumulating in the sensor.

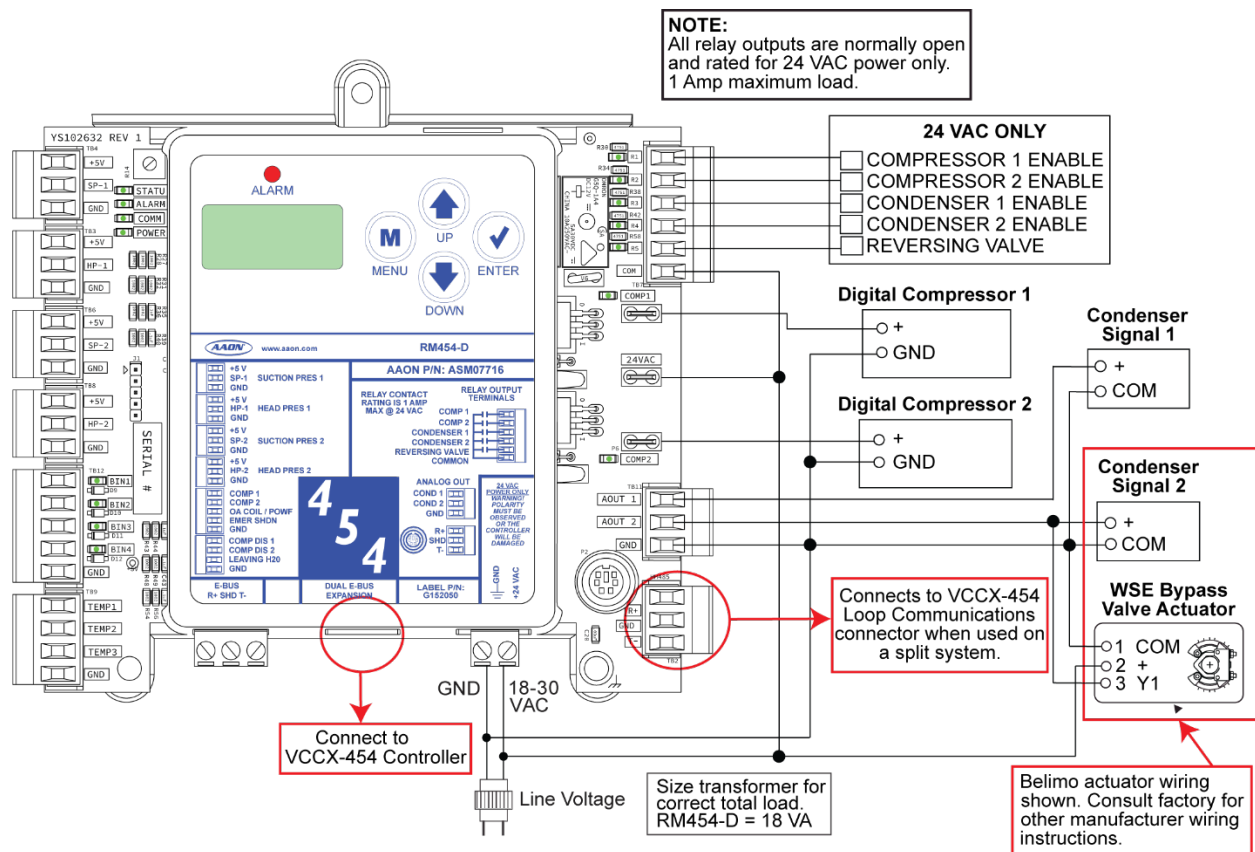

Figure 3: RM454-D Outputs Wiring

5. INPUTS AND OUTPUTS

5.1. Map

5.1.1. Inputs/Outputs Map

Table 3: RM454-D Inputs and Outputs

Refrigeration System Module For Digital Compressors	
Analog Inputs	
SP-1	Suction Pressure 1 Transducer
HP-1	Head Pressure 1 Transducer
SP-2	Suction Pressure 2 Transducer
HP-2	Head Pressure 2 Transducer
TEMP1	Compressor Discharge Temperature Sensor 1
TEMP2	Compressor Discharge Temperature Sensor 2 (used on heat pumps only)
TEMP3	Leaving Water Temperature Sensor
Binary Inputs	
BIN1	Compressor Status 1
BIN2	Compressor Status 2
BIN3	Outside Coil Temperature / Proof of Water Flow
BIN4	Emergency Shutdown
Analog Outputs (0-10 VDC)	
AOUT1	Condenser 1 Fan Signal
AOUT2	Not Used
Relay Outputs	
R1	Compressor 1 Enable Relay
R2	Compressor 2 Enable Relay
R3	Condenser 1 Enable Relay
R4	Condenser 2 Enable Relay
R5	Reversing Valve Relay

5.2. RM454-D Inputs and Outputs

+5V – VDC Power

This output is a 5 VDC output that supplies power to the Suction Pressure Transducers.

SP-1 and SP-2 – Suction Pressure Transducers

The Suction Pressure Transducers are used to measure suction pressure at the HVAC unit's DX evaporator coil suction line. This suction line pressure is converted to saturated refrigerant temperature. The saturated refrigerant temperature is used to properly control the compressors to maintain a given Suction Coil (Saturated) Temperature Setpoint. In Cooling Mode, the VCCX2 resets the Suction Coil (Saturated) Temperature Setpoint to maintain a given Supply Air Temperature Setpoint. In Dehumidification Mode, the Suction Coil (Saturated) Temperature Setpoint is a user configurable setpoint that can be reset based on indoor humidity levels.

+5V – VDC Power

This output is a 5 VDC output that supplies power to the Head Pressure Transducers.

HP-1 and HP-2 – Head Pressure Transducers

The Head Pressure Transducers are used to measure Head Pressure at the discharge line. This Head Pressure is used to drive the condenser fans to maintain a given Head Pressure Setpoint.

TEMP1 and TEMP2 – Compressor Discharge Temperature Sensor 1 and Sensor 2 Input

The Digital Compressor Discharge Temperature Sensors monitor the discharge temperature from the digital compressor to protect against overheating.

TEMP3 – Leaving Water Temperature Sensor Input

This input monitors the condenser leaving water temperature and determines if the condenser is operating in a safe water temperature range.

BI1 – Compressor Status 1

When this wet contact input closes, a 24 volt signal indicates Compressor 1 is running. Typically, the source for this is the auxiliary contacts on the compressor contactor after it has run through the compressor safeties. If Binary Input 1 opens, Compressor 1 Enable Relay de-energizes and a compressor alarm is generated.

BI2 – Compressor Status 2

When this wet contact input closes, a 24 volt signal indicates Compressor 2 is running. Typically, the source for this is the auxiliary contacts on the compressor contactor after it has run through the compressor safeties. If Binary Input 2 opens, Compressor 2 Enable Relay de-energizes and a compressor alarm is generated.

BI3 – Outdoor Coil Temperature / Proof of Water Flow Status

This input can be used for the following two options:

Air to Air Heat Pump: This wet contact input monitors a defrost coil temperature switch on air to air heat pump units. If the compressors are operating in the Heating Mode and this switch closes, it initiates a Defrost Mode.

Water Source Heat Pump: This wet contact input is for the Water Proof of Flow Switch. If the Water Proof of Flow Switch contact opens while the condenser valve is operating, the controller reacts to protect the system depending on the current mode of operation.



Inputs and Outputs (Continued)

BI4 - Emergency Shutdown

This wet contact input is used to initiate shutdown of the HVAC unit when a normally closed smoke detector (by others), firestat (by others), or other shutdown condition (by others) contact is opened. The controller remains active and can initiate alarm relays.

Note: The binary inputs require wet contacts (24 VAC only) to recognize an active input. If a dry contact is provided, the contact closure will not be recognized.

A01 - Condenser 1 Fan Signal

This 0–10 VDC output is used to control/modulate the Condenser 1 Fan / Valve to maintain the Head Pressure Setpoint.

A02 - Condenser 2 Fan Signal or Waterside Economizer Bypass Actuator Valve

This 0–10 VDC output is used to control/modulate the Condenser 2 Fan / Valve to maintain the Head Pressure Setpoint or this output signal is a Direct Acting 2–10 VDC output signal that is used to modulate the Waterside Economizer Bypass Actuator.

RLY1 - Compressor 1 Enable

This relay enables Compressor 1.

RLY2 - Compressor 2 Enable

This relay enables Compressor 2.

RLY3 - Condenser 1 Enable

This relay enables Condenser 1 Fan / Water Valve.

RLY4 - Condenser 2 Enable

This relay enables Condenser 2 Fan / Water Valve.

RLY5 - Reversing Valve Enable

This relay enables the Reversing Valve.

6. SEQUENCE OF OPERATIONS

6.1. Prism 2 Configuration

Prism 2 software must be used to configure the RM454-D Module.

The Prism 2 software simplifies unit setup by identifying the type of compressor and condenser fan setup. In the Setpoints screens (*Unit Selection > Details Viewer > Setpoints > Open Setpoints*), click on the RSMDMod tab to bring up its configuration screen. Figure 4, this page, shows an example of what the screen might look like.

Note: The unit tonnage is the first number listed in the model number on the nameplate.

Enter the *Unit Tonnage* to see the model numbers for that tonnage. For all tonnages available, there are four options shown:

- RNA-XXX-*-AAA for non-heat pump units without digital compressors.
- RNA-XXX-*-AAB for heat pump units without digital compressors.
- RNA-XXX-*-DAA for non-heat pump units with digital compressors.
- RNA-XXX-*-DAB for heat pump units with digital compressors.

Once an option is selected, the voltage, tonnage, and the number of evaporator rows are shown.

Altitude

Enter the altitude of the location of the unit. An internet search for the altitude of the city in which the job is located is sufficient. The altitude entered is used for calculating the Saturated Suction Pressure Temperature.

Figure 4: Prism 2 RM454-D Configuration Screen

Figure 5: Prism 2 RM454-D Configuration Options

6.2. Mode of Operation

6.2.1. Cooling and Heating Modes

Staging of the compressors is determined by the Supply Air Temperature setpoint not being satisfied. Staging is met by turning the VFD compressors and on/off compressor on or off, or the two-step compressor to low speed (two-thirds, 67%, capacity) or to high speed (full, 100%, capacity).

During Cooling Mode, the digital compressor modulation is determined from the Saturation Temperature. During Heating Mode, the digital compressor modulation is determined from the Supply Air Temperature.

Compressor envelope protections also affect the VFD compressor modulation.

6.2.2. Dehumidification Operation

Dehumidification Mode control staging and VFD modulation is determined using the Saturation Temperature from each circuit.

Note: Compressor 2 cannot be turned off in Dehumidification Mode unless it shuts down because of an alarm fault.

6.2.3. Head Pressure Control

The RM454-D can monitor a head pressure transducer and control a condenser fan to maintain a Head Pressure Setpoint.

The condenser fan starting speed varies based on outside air temperatures. At 40°F or colder, the fan starts at 10%; at 70°F or warmer, the fan starts at 100%. Starting speed adjusts linearly between 40°F and 70°F.

In Cooling Mode, the condenser fan modulates speeds to target the discharge pressure setpoint based on the highest running circuit it is controlling. This is also true for Dehumidification Mode and has a separate discharge pressure setpoint adjustable in Prism 2.

In Heat Pump Heating, the outside fan modulates speeds to target the outside approach temperature setpoint, which is outside temperature minus the lowest saturation temperature of the running circuit it is controlling.

If the pressure exceeds 575 psig, the circuit shuts down in an attempt to fail before the mechanical high-pressure switch opens. The circuit is allowed to restart after five minutes.

If no head pressure is detected on a circuit, the compressor is disabled and not allowed to run. If the head pressure reading is lost while the circuit is on, the condenser signal goes to 100% until the compressor shuts down.

6.3. Staging

Note: Slight changes may occur based on minimum run times and off times.

Note: The RM454-D will transition to the most appropriate state depending on the configuration and environmental conditions.



If compressors are operating in a configuration not shown, it could be due to environmental conditions, compressor availability, or alarm conditions.



Initial transitions between states may lower capacity during the transition.

Table 4: Staging - RM454-D 1 Circuit: Digital Cooling States

1 RM454-D 1 Circuit Digital Cooling			
Circuit	Compressor Type	State 0	State 1
A1	Digital	Off	On (Modulating)

Table 5: Staging - 2 RM454-D 2 Circuit: Digital, On/Off + On/Off Cooling States

2 RM454-D 2 Circuit: Digital, On/Off + On/Off Cooling					
Circuit	Compressor Type	State 0	State 1	State 2	State 3
A1	Digital	OFF	ON (Modulating)	ON (Modulating)	ON (Modulating)
B1	On/Off	OFF	OFF	OFF	ON
B2	On/Off	OFF	OFF	ON	ON

Table 6: Staging - 2 RM454-D 2 Circuit: Digital, On/Off + On/Off Reheat States

2 RM454-D 2 Circuit: Digital, On/Off + On/Off Secondary (Second Circuit) Reheat					
Circuit	Compressor Type	State 0	State 1	State 2	State 3
A1	Digital	OFF	OFF	ON	ON
B1	On/Off	OFF	ON	OFF	ON
B2	On/Off	ON	ON	ON	ON

Table 7: 2 RM454-D 2 Circuit: Digital + On/Off, Digital + On/Off Cooling States

2 RM454-D 2 Circuit: Digital, On/Off + On/Off Cooling					
Circuit	Compressor Type	State 0	State 1	State 2	State 3
A1	Digital	OFF	ON (Modulating)	ON (Modulating)	ON (Modulating)
A2	On/Off	OFF	OFF	OFF	ON
B1	On/Off	OFF	OFF	ON	ON
B2	On/Off	OFF	OFF	OFF	OFF

Table 8: Staging - 2 RM454-D 2 Circuit: Digital + On/Off + On/Off Cooling States

2 RM454-D 2 Circuit: Digital + On/Off, On/Off + On/Off Cooling								
Circuit	Compressor Type	State 0	State 1	State 2a	State 2b	State 3a	State 3b	State 4
A1	Digital	OFF	ON (Modulating)	ON (Modulating)	ON (Modulating)	ON (Modulating)	ON (Modulating)	ON (Modulating)
A2	On/Off	OFF	OFF	OFF	OFF	OFF	ON	ON
B1	On/Off	OFF	OFF	ON	OFF	ON	OFF	ON
B2	On/Off	OFF	OFF	OFF	ON	ON	ON	ON

Table 9: Staging - 2 RM454-D 2 Circuit: Digital + On/Off, On/Off + On/Off Reheat States

2 RM454-D 2 Circuit: Digital, On/Off + On/Off Secondary (Second Circuit) Reheat						
Circuit	Compressor Type	State 1	State 2a	State 2b	State 3	State 4
A1	Digital	OFF	OFF	ON (Modulating)	ON (Modulating)	ON (Modulating)
A2	On/Off	OFF	OFF	OFF	OFF	ON
B1	On/Off	ON	ON	ON	ON	ON
B2	On/Off	OFF	ON	OFF	ON	ON

Table 10: Staging - 2 RM454-D 4 Circuit: Digital, Digital, 2-Step, 2-Step RNA-D Units Cooling States

2 RM454-D 4 Circuit: Digital, Digital, 2-Step, 2-Step RNA-D Units Cooling					
Circuit	Compressor Type	State 0	State 1	State 2	State 3
A1	Digital	OFF	ON (Modulating)	ON (Modulating)	ON (Modulating)
B1	Digital	OFF	ON (Modulating)	ON (Modulating)	ON (Modulating)
C1	2-Step	OFF	OFF	LOW	HIGH
D1	2-Step	OFF	OFF	LOW	HIGH

Table 11: Staging - 2 RM454-D 4 Circuit: Digital, Digital, 2-Step, 2-Step RNA-D Units Reheat States

2 RM454-D 2 Circuit: Digital, Digital, 2-Step, 2-Step RNA-D Units Secondary (Second Circuit) Reheat				
Circuit	Compressor Type	State 1	State 2	State 3
A1	Digital	OFF	OFF	ON (Modulating)
B1	Digital	OFF	OFF	ON (Modulating)
C1	2-Step	LOW	HIGH	HIGH
D1	2-Step	LOW	HIGH	HIGH

Table 12: Staging - RM454-D 2 Circuit: Digital, 2-Step Cooling States

1 RM454-D 2 Circuit: Digital, 2-Step Cooling					
Circuit	Compressor Type	State 0	State 1	State 2	State 3
A1	Digital	OFF	ON (Modulating)	ON (Modulating)	ON (Modulating)
B1	Digital	OFF	ON (Modulating)	ON (Modulating)	ON (Modulating)

Table 13: Staging - 1 RM454-D 2 Circuit: Digital, 2-Step Reheat States

1 RM454-D 2 Circuit: Digital, 2-Step Secondary (Second Circuit) Reheat				
Circuit	Compressor Type	State 1	State 2	State 3
A1	Digital	OFF	OFF	ON (Modulating)
B1	2-Step	LOW	HIGH	HIGH

Table 14: Staging - 1 RM454-D 2 Circuit: Digital, On/Off Cooling States

1 RM454-D 2 Circuit: Digital, On/Off Cooling				
Circuit	Compressor Type	State 0	State 1	State 2
A1	Digital	OFF	ON (Modulating)	ON (Modulating)
B1	On/Off	OFF	OFF	ON

Table 15: Staging - 1 RM454-D 2 Circuit: Digital, On/Off Reheat States

1 RM454-D 2 Circuit: Digital, On/Off Secondary (Second Circuit) Reheat			
Circuit	Compressor Type	State 1	State 2
A1	Digital	OFF	ON
B1	On/Off	ON	ON

Table 16: Staging - 2 RM454-D 4 Circuit: Digital, On/Off, Digital, On/Off Cooling States

2 RM454-D 4 Circuit: Digital, On/Off, Digital, On/Off Cooling					
Circuit	Compressor Type	State 0	State 1	State 2	State 3
A1	Digital	OFF	ON (Modulating)	ON (Modulating)	ON (Modulating)
B1	On/Off	OFF	OFF	ON	ON
C1	Digital	OFF	ON (Modulating)	ON (Modulating)	ON (Modulating)
D1	On/Off	OFF	OFF	OFF	ON

Table 17: Staging - 2 RM454-D 4 Circuit: Digital, On/Off, Digital, On/Off Reheat States

2 RM454-D 4 Circuit: Digital, On/Off, Digital, On/Off Secondary (Second Circuit) Reheat				
Circuit	Compressor Type	State 0	State 1	State 2
A1	Digital	OFF	ON (Modulating)	ON (Modulating)
B1	On/Off	ON	ON	ON
C1	Digital	OFF	OFF	ON (Modulating)
D1	On/Off	ON	ON	ON

Table 18: Staging - 2 RM454-D 2 Circuit: Digital, Digital Cooling States

2 RM454-D 2 Circuit: Digital, Digital – Heat Pumps That Cannot Share RV Cooling				
Circuit	Compressor Type	State 0	State 1	State 2
A1	Digital	OFF	ON (Modulating)	ON (Modulating)
B1	Digital	OFF	OFF	ON (Modulating)

Table 19: Staging - 2 RM454-D 2 Circuit: Digital, Digital Reheat States

2 RM454-D 2 Circuit: Digital, Digital – Heat Pumps That Cannot Share RV Secondary (Second Circuit) Reheat			
Circuit	Compressor Type	State 1	State 2
A1	Digital	OFF	ON (Modulating)
B1	Digital	ON (Modulating)	ON (Modulating)

Table 20: Staging - 1 RM454-D 2 Circuit: Digital, Digital Cooling States

1 RM454-D 2 Circuit: Digital, Digital – Cooling-Only Units Cooling				
Circuit	Compressor Type	State 0	State 1	State 2
A1	Digital	OFF	ON (Modulating)	ON (Modulating)
B1	Digital	OFF	OFF	ON (Modulating)

Table 21: Staging - 1 RM454-D 2 Circuit: Digital, Digital Reheat States

1 RM454-D 2 Circuit: Digital, Digital – Cooling-Only Units Secondary (Second Circuit) Reheat				
Circuit	Compressor Type	State 0	State 1	State 2
A1	Digital	OFF	OFF	ON (Modulating)
B1	Digital	OFF	ON (Modulating)	ON (Modulating)

Table 22: Staging - 2 RM454-D 4 Circuit: Digital, 2-Step, Digital 2-Step CF 20-ton Units and SA 70-ton Units Cooling States

2 RM454-D 4 Circuit: Digital, 2-Step, Digital, 2-Step CF 20-ton Units and SA 70-ton Units Cooling					
Circuit	Compressor Type	State 0	State 1	State 2	State 3
A1	Digital	OFF	ON (Modulating)	ON (Modulating)	ON (Modulating)
B1	2-Step	OFF	OFF	LOW	HIGH
C1	Digital	OFF	ON (Modulating)	ON (Modulating)	ON (Modulating)
D1	2-Step	OFF	OFF	LOW	HIGH

Table 23: Staging - 2 RM454-D 4 Circuit: Digital, 2-Step, Digital, 2-Step CF 20-ton Units and SA 70-ton Units Reheat States

2 RM454-D 4 Circuit: Digital, 2-Step, Digital, 2-Step CF 20-ton Units and SA 70-ton Units Secondary (Secondary Circuit) Reheat				
Circuit	Compressor Type	State 1	State 2	State 3
A1	Digital	OFF	OFF	ON (Modulating)
B1	2-Step	LOW	HIGH	HIGH
C1	Digital	OFF	OFF	ON (Modulating)
D1	2-Step	LOW	HIGH	HIGH

Table 24: Staging - 2 RM454-D 2 Circuit: On/Off + On/Off, On/Off + On/Off Cooling States

2 RM454-D 2 Circuit: On/Off + On/Off + On/Off Cooling								
Circuit	Compressor Type	State 0	State 1	State 2	State 3	State 4	State 5	State 6
A1	On/Off	OFF	ON	OFF	ON	ON	ON	ON
A2	On/Off	OFF	OFF	ON	ON	ON	ON	ON
B1	On/Off	OFF	OFF	OFF	OFF	ON	OFF	ON
B2	On/Off	OFF	OFF	OFF	OFF	OFF	ON	ON

Table 25: Staging - 2 RM454-D 2 Circuit: On/Off + On/Off, On/Off+ On/Off Reheat States

2 RM454-D 2 Circuit: On/Off + On/Off, On/Off + On/Off Secondary (Second Circuit) Reheat						
Circuit	Compressor Type	State 1	State 2	State 3a	State 3b	State 4
A1	On/Off	OFF	OFF	ON	OFF	ON
A2	On/Off	OFF	OFF	OFF	ON	ON
B1	On/Off	OFF	ON	ON	ON	ON
B2	On/Off	ON	ON	ON	ON	ON

Table 26: Staging - 1 RM454-D 2 Circuit On/Off + On/Off Cooling States

1 RM454-D 1 Circuit: On/Off Cooling			
Circuit	Compressor Type	State 0	State 1
A1	On/Off	OFF	ON

Table 27: Staging - 1 RM454-D 2 Circuit: On/Off + On/Off Cooling States

1 RM454-D 2 Circuit On/Off + On/Off Cooling				
Circuit	Compressor Type	State 0	State 1	State 2
A1	On/Off	OFF	ON	ON
B1	On/Off	OFF	OFF	ON

Table 28: Staging - 2 RM454-D 2 Circuit: On/Off, On/Off Cooling States

2 RM454-D 2 Circuit: On/Off, On/Off – For Heat Pumps That Cannot Share I/O Cooling				
Circuit	Compressor Type	State 0	State 1	State 2
A1	On/Off	OFF	ON	ON
B1	On/Off	OFF	OFF	ON

Table 29: Staging - 1 RM454-D 1 Circuit: 2-Step Cooling States

1 RM454-D 1 Circuit: 2-Step Cooling				
Circuit	Compressor Type	State 0	State 1	State 2
A1	2-Step	OFF	LOW	HIGH

Table 30: Staging - 1 RM454-D 2 Circuit: 2-Step, 2-Step Cooling States

1 RM454-D 2 Circuit: 2-Step, 2-Step Cooling							
Circuit	Compressor Type	State 0	State 1	State 2	State 3	State 4	State 5
A1	2-Step	OFF	LOW	HIGH	LOW	HIGH	HIGH
B1	2-Step	OFF	OFF	OFF	LOW	LOW	HIGH

Table 31: Staging - RM454-D 2 Circuit: 2-Step, 2-Step Reheat States

1 RM454-D 2 Circuit: 2-Step, 2-Step Secondary (Second Circuit) Reheat					
Circuit	Compressor Type	State 1	State 2	State 3	State 4
A1	2-Step	OFF	OFF	LOW	HIGH
B1	2-Step	LOW	HIGH	HIGH	HIGH

Table 32: Staging - 2 RM454-D 4 Circuit: 2-Step, 2-Step, 2-Step, 2-Step Cooling States

2 RM454-D 4 Circuit: 2-Step, 2-Step, 2-Step, 2-Step Cooling							
Circuit	Compressor Type	State 0	State 1	State 2	State 3	State 4	State 5
A1	2-Step	OFF	LOW	HIGH	LOW	HIGH	HIGH
B1	2-Step	OFF	LOW	HIGH	LOW	HIGH	HIGH
C1	2-Step	OFF	OFF	OFF	LOW	LOW	HIGH
D1	2-Step	OFF	OFF	OFF	LOW	LOW	HIGH

Table 33: Staging - 2 RM454-D 4 Circuit: 2-Step, 2-Step, 2-Step, 2-Step Reheat States

2 RM454-D Circuit: 2-Step, 2-Step, 2-Step, 2-Step Secondary (Second Circuit) Reheat					
Circuit	Compressor Type	State 1	State 2	State 3	State 4
A1	2-Step	OFF	OFF	LOW	HIGH
B1	2-Step	OFF	OFF	LOW	HIGH
C1	2-Step	LOW	HIGH	HIGH	HIGH
D1	2-Step	LOW	HIGH	HIGH	HIGH

Table 34: Staging - 2 RM454-D 2 Circuit: 2-Step, 2-Step Cooling States

2 RM454-D 2 Circuit: 2-Step, 2-Step Cooling							
Circuit	Compressor Type	State 0	State 1	State 2	State 3	State 4	State 5
A1	2-Step	OFF	LOW	HIGH	LOW	HIGH	HIGH
B1	2-Step	OFF	OFF	OFF	LOW	LOW	HIGH

Table 35: Staging - 2 RM454-D 2 Circuit: 2-Step, 2-Step Reheat States

2 RM454-D Circuit: 2-Step, 2-Step Secondary (Second Circuit) Reheat					
Circuit	Compressor Type	State 1	State 2	State 3	State 4
A1	2-Step	OFF	OFF	LOW	HIGH
B1	2-Step	LOW	HIGH	HIGH	HIGH

Table 36: Staging - 4 RM454-D 4 Circuit: 2-Step, 2-Step, 2-Step, 2-Step Cooling States

4 RM454-D 4 Circuit: 2-Step, 2-Step, 2-Step, 2-Step for Heat Pumps That Cannot Share I/O Cooling							
Circuit	Compressor Type	State 0	State 1	State 2	State 3	State 4	State 5
A1	2-Step	OFF	LOW	HIGH	LOW	HIGH	HIGH
B1	2-Step	OFF	LOW	HIGH	LOW	HIGH	HIGH
C1	2-Step	OFF	OFF	OFF	LOW	LOW	HIGH
D1	2-Step	OFF	OFF	OFF	LOW	LOW	HIGH

Table 37: Staging - 4 RM454-D 4 Circuit: 2-Step, 2-Step, 2-Step, 2-Step Reheat States

4 RM454-D 4 Circuit: 2-Step, 2-Step, 2-Step, 2-Step for Heat Pumps that Cannot Share I/O Secondary (Second Circuit) Reheat					
Circuit	Compressor Type	State 1	State 2	State 3	State 4
A1	2-Step	OFF	OFF	LOW	HIGH
B1	2-Step	OFF	OFF	LOW	HIGH
C1	2-Step	LOW	HIGH	HIGH	HIGH
D1	2-Step	LOW	HIGH	HIGH	HIGH

Table 38: Staging - 2 RM454-D 4 Circuit: 2-Step, 2-Step, 2-Step, 2-Step Cooling States

2 RM454-D 4 Circuit: 2-Step, 2-Step, 2-Step, 2-Step Cooling							
Circuit	Compressor Type	State 0	State 1	State 2	State 3	State 4	State 5
A1	2-Step	OFF	LOW	HIGH	LOW	HIGH	HIGH
B1	2-Step	OFF	OFF	OFF	LOW	LOW	HIGH
C1	2-Step	OFF	LOW	HIGH	LOW	HIGH	HIGH
D1	2-Step	OFF	OFF	OFF	LOW	LOW	HIGH

Table 39: Staging - 2 RM454-D 4 Circuit: 2-Step, 2-Step, 2-Step, 2-Step Reheat States

2 RM454-D 4 Circuit: 2-Step, 2-Step, 2-Step, 2-Step Secondary (Second Circuit) Reheat					
Circuit	Compressor Type	State 1	State 2	State 3	State 4
A1	2-Step	OFF	OFF	LOW	HIGH
B1	2-Step	LOW	HIGH	HIGH	HIGH
C1	2-Step	OFF	OFF	LOW	HIGH
D1	2-Step	LOW	HIGH	HIGH	HIGH



Table 40: Staging - 2 RM454-D 2 Circuit: Tandem Fixed, Fixed, Tandem Fixed, Fixed Cooling States

2 RM454-D 2 Circuit: Tandem Fixed, Fixed, Tandem Fixed, Fixed Cooling							
Circuit	Compressor Type	State 0	State 1	State 2	State 3	State 4	State 5
A1	Tandem Fixed	OFF	ON	ON	ON	ON	A1
A2	Fixed	OFF	OFF	OFF	ON	ON	A2
B1	Tandem Fixed	OFF	OFF	ON	ON	ON	B1
B2	Fixed	OFF	OFF	OFF	OFF	ON	B2

Table 41: Staging - 2 RM454-D 4 Circuit; Tandem Digital, Fixed, Tandem Fixed, Fixed Cooling States

2 RM454-D 2 Circuit: Tandem Digital, Fixed, Tandem Fixed, Fixed Cooling						
Circuit	Compressor Type	State 0	State 1	State 2	State 3	State 4
A1	Tandem Digital	OFF	ON (Modulating)	ON (Modulating)	ON (Modulating)	ON (Modulating)
A2	Fixed	OFF	OFF	OFF	ON	ON
B1	Tandem Fixed	OFF	OFF	ON	ON	ON
B2	Fixed	OFF	OFF	OFF	OFF	ON

6.4. Envelope Protection

Compressor manufacturer specifications require the compressor to operate within its given operating envelope to maintain the life and longevity of the compressor. Some envelopes also have areas within that limit the minimum/maximum operating speeds. Min/max speeds may also be limited based on the requirements of the unit's total capacity. The Prism 2 interface allows the ability to see real-time envelope plotting while the compressor is running.

The minimum operating speed reference is read from the VFD and can change depending on where the compressor is operating within its envelope.

The VFD compressor is set to 67% at any stage event. Therefore, whenever a staging event occurs, the VFD compressor position is reset to the middle point of the modulation range. This allows the compressor enough modulation time before making another staging event to try to avoid cycling between staging events.

Figures 6 and 7, this page, are examples of compressor envelopes.

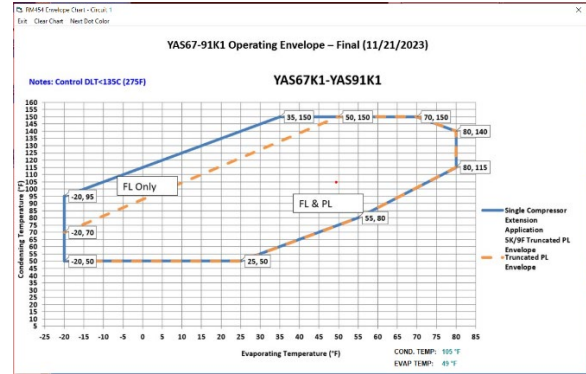

Figure 6: Copeland YAS67K1-91K1 and R454 Envelope

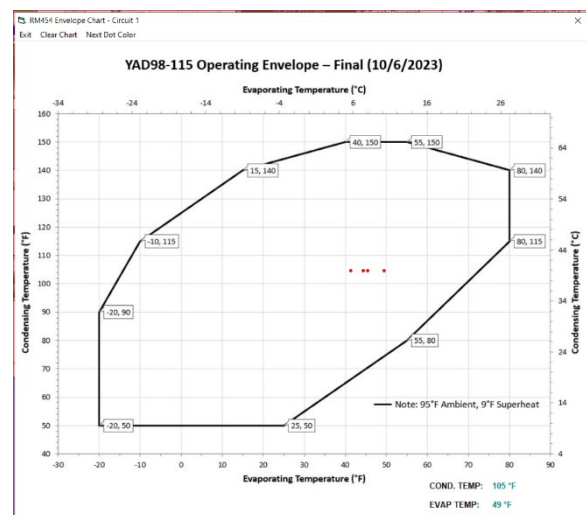

Figure 7: Copeland YAD98-115 Envelope

7. LCD SCREENS

7.1. Display Screen and Navigation Keys

7.1.1. LCD Display Screen and Navigation Keys

The LCD display screens and buttons allow viewing of status and alarms, and enable force modes. See Figure 8, this page, and refer to Table 42, this page, for descriptions.

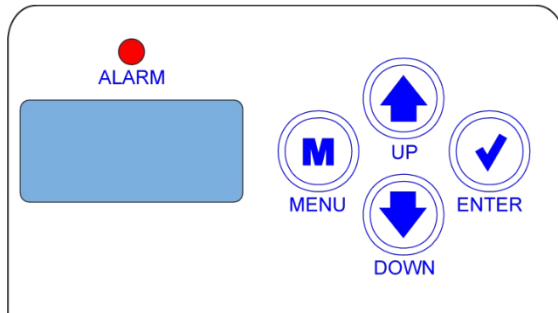

Figure 8: LCD Display and Navigation Keys

Table 42: Navigation Key Functions

Navigation Key Functions	
Key	Function
MENU 	Use the <MENU> key to move through screens within Main Menu categories and return to the Main Menu while at other screens.
UP 	Use this key to adjust setpoints and change configurations.
DOWN 	Use this key to adjust setpoints and change configurations.
ENTER 	Use the <ENTER> key to navigate through the Main Menu Screen categories.

7.2. Screens Map

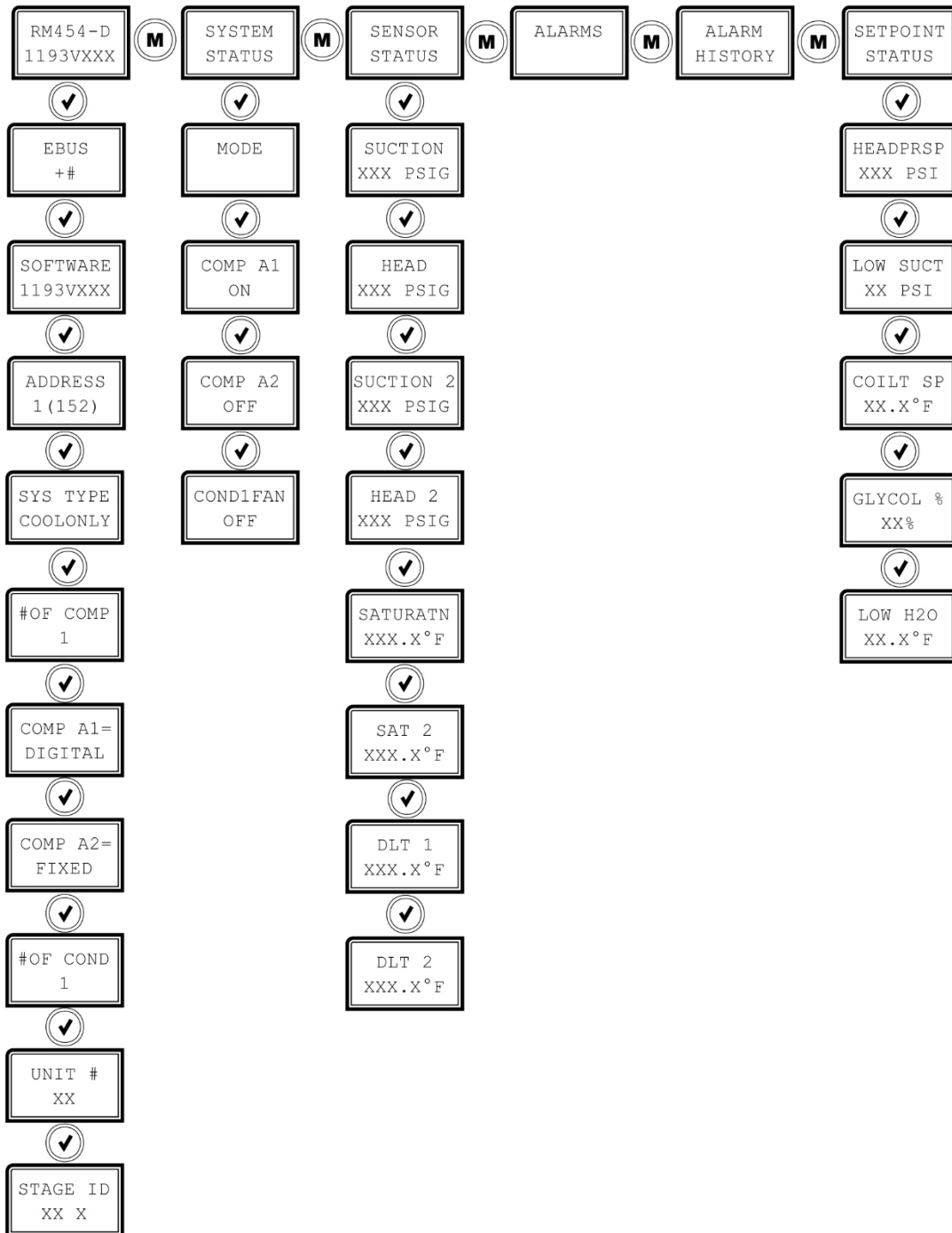

Figure 9: LCD Screens Map

7.3. Screen Descriptions

7.3.1. Main Screens

Refer to the following table when navigating through the LCD Main Screens.

Press the **<MENU>** button to navigate between the top level screens.

Press the **<ENTER>** button to scroll through the next level screens.

Table 43: Main Screens

Main Screens	
Screen Text	Description
RM454-D 1193VXXX	Refrigeration module screens. The second line shows the software number and its version.
System Status	System status screens
Sensor Status	Sensor status screens
No Alarms	Alarm status screens. Screen shows NO ALARMS if no alarms are active.
No Alarm History	Alarm history screens. Screen shows NO ALARM HISTORY if no alarms have been activated.
Setpoint Status	Setpoint status screens

The RM454-D (ASM07716) uses a PIC32 Processor. The PIC32 processor requires software version SS1193. The software version is identified on the software label near the Status LED or when using the Software Version screen.



WARNING

The correct software version must be used for all software upgrades. Loading the incorrect software could result in a malfunction. Contact AAON Technical Support for assistance, if required.

7.3.2. Module Screens

Refer to the following table when navigating through the module screens. From the RM454-D screen, press <ENTER> to scroll through the screens.

Table 44: Module Screens

Module Screens	
Screen Text	Description
RM454-D 1193VXXX	Refrigeration module screens. The second line shows the software number and its version.
EBUS +XXX	E-BUS communication. XXX equals the number of COMM packets received. The number increases as packets are received.
SOFTWARE 1168VXXX	Current software version. The second line shows the software number and its version. Access the protected screens from this screen by holding the <UP> button for five seconds.
ADDRESS 1(152)	Current board address. The first number is the board address. The number in the parentheses is the EBUS address.
SYS TYPE COOLING ONLY	Current system type. Possible options for the second line are: <ul style="list-style-type: none"> • COOLONLY • AIR HP or WSHP
#OF COMP X	The number of compressors configured. The X equals only 1 or 2, depending on how many compressors the system is configured for.
COMP A1 DIGITAL	If using a second address, this will read COMP B1. The first compressor installed can be fixed or digital.
COMP A2 FIXED	The screen will read either DIGITAL or FIXED.
#OF COND X	Used only if a second compressor is installed. If using a second address, this will read COMP B2. The second compressor installed will always be fixed.
UNIT # XXX	Number of condensers controlled by this module.
STAGE ID XX	Units numbered 1 through XXX. Shows which unit has been selected. Matches the unit # shown in Prism 2.

7.3.3. System Status Screens

Refer to the following map when navigating through the System Status Screens. From the System Status Screen, press <ENTER> to scroll through the screens.

Table 45: System Status Screens

System Status Screens	
Screen Text	Description
SYSTEM STATUS	System status screens
MODE OFF	System mode. Options are: <ul style="list-style-type: none"> • Min Run • Off • Cooling • Heating • Dehum • Forced
COMP A1 ON	ON/OFF OR MOD%. ON/OFF: Compressor is on or off. MODULATING %: 0-100%.
COMP A2 OFF	ON, OFF, FORCED ON/OFF: Compress is on or off. FORCED: Compressor is forced on or off from a hidden screen.
COND1FAN OFF	OFF/MOD% OFF: Condenser is off. MODULATING %: 0-100%

7.3.4. Sensor Status Screens

Refer to the following map when navigating through the Sensor Status Screens. From the SENSOR STATUS Screen, press <ENTER> to scroll through the screens.

Table 46: Sensor Status Screens

Sensor Status Screens	
Screen Text	Descriptions
SENSOR STATUS	Sensor status screens
SUCTION XXX PSIG	Suction pressure reading from input. Measured in PSIG.
HEAD XXX PSIG	Head pressure reading from input. Measured in PSIG.
SATURATN XXX.X°F	Calculated saturation coil temperature from suction pressure input. Measured in degrees Fahrenheit.
DLT X XXX.X°F	Discharge line temperature from TEMP1 input. Measured in degrees Fahrenheit.

7.3.5. Setpoint Status Screens

Refer to the following map when navigating through the Setpoint Status Screens. From the SETPOINT STATUS Screen, press <ENTER> to scroll through the screens.

Table 47: Setpoint Status Screens

Setpoint Status Screens	
Screen Text	Description
SETPOINT STATUS	Setpoint Status screens
HEADPRSP XXX PSIG	Head Pressure Setpoint. Valid range is 260-475 PSIG. Default is 340 PSIG. Measured in PSIG.
LOW SUCT XX PSIG	Low Suction Pressure Setpoint. Default is 95 PSIG. Measured in PSIG.
COILT SP XX.X°F	Coil Temperature Setpoint. Valid range is 35-70°F. Default is 35°F. Measured in degrees Fahrenheit.

7.4. Alarm Screens

If an alarm is present, the ALARM LED above the LCD display lights up red and blinks. The Alarms display and scroll automatically from the ALARMS screen when alarms are present. The alarms are as follows:

Table 48: Alarm Screens

Alarms Screens	
Screen Text	Descriptions
ALARMS	Alarms Status screens
EBUS COM TIMEOUT	This alarm indicates communication has been lost between the RM454-D and the AAON controller or other E-BUS modules that may be connected. This can be the result of a bad cable, a missing cable, or the module not being configured properly. This alarm will clear 5 minutes after communication is established.
NO SUCT DETECTED	This alarm indicates the Suction Pressure Transducer 1 is not detected by the system. There is no compressor failure from this alarm. The compressor will not activate if no suction pressure is detected.
NO HEAD DETECTED	This alarm indicates the Head Pressure Transducer 1 is not detected by the system. This causes the condenser fan/valve to go to 100%.
HIGH HP DETECTED	This indicates a High Head Pressure Alarm condition, which is activated when the Head Pressure 1 rises above 470 PSIG. This causes the condenser to go to 100%.
LOW SP FAILURE	This alarm occurs if Suction Pressure 1 stays below the Low Suction Pressure Setpoint for one minute or falls below 39 psi for five seconds. This alarm shuts down the system. Power must be cycled to clear the alarm.
LOW SP DETECTED	This alarm occurs if Suction Pressure 1 falls below the Low Suction Pressure Setpoint for 20 seconds. The system will try to protect itself by lowering the compressor modulation percentage.
COMP A1 FAULT	This alarm occurs if the compressor fails to run 45 seconds after the relay is activated or if the signal is lost after activation. This causes an alarm and shuts down the Compressor A1 Enable Relay. The system will retry after five minutes.
COMP B1 FAULT	(Address 2) This alarm occurs if the compressor fails to run 45 seconds after the relay is activated or if the signal is lost after activation. This causes an alarm and shuts down the Compressor B1 Enable Relay. The system will retry after five minutes.
HIGH HP1 TRIP	High Pressure Trip occurs at 570 psig
NO ALARMS	This is shown if there are no current alarms.
COMP A2 FAULT	This alarm occurs if the compressor fails to run 45 seconds after the relay is activated or if the signal is lost after activation. This causes an alarm and shuts down the Compressor A2 Enable Relay. The system will retry after five minutes.
COMP B2 FAULT	(Address 2) This alarm occurs if the compressor fails to run 45 seconds after the relay is activated or if the signal is lost after activation. This causes an alarm and shuts down the Compressor B2 Enable Relay. The system will retry after five minutes.
DIGCOMP1 FAIL and COMP 1 CUTOFF	This alarm occurs if the Discharge Temp Sensor 1 measures more than 220°F. This causes an alarm and shuts down the Compressor Enable Relay. The system can be restarted after 30 minutes.
NO WATER FLOW	This alarm occurs if there is a call for a compressor and the Proof of Water Flow Switch does not close for more than three minutes or if, during Heat Pump heating, the Proof of Water Flow Switch is open for more than two seconds. This alarm disables when the Proof of Water Flow Switch closes.



Alarms Screens	
Screen Text	Descriptions
LOW H ₂ O TEMP	If both compressors are on and the water temperature goes below the setpoint, Compressor 2 will fail. If both compressors are on and the water temperature goes 3°F below the setpoint, both compressors will fail. If Compressor 2 is off or failed and the water temperature is still low for one minute, Compressor 1 will also fail. This alarm disables when the leaving water temperature rises 6°F above the setpoint.
EMERGENCY SHUTDOWN	If the Emergency Shutdown binary input is not activated, the compressors shut off.
ENVELOPE FAULT	If the circuit is running outside the envelope consecutively for one minute, the compressor(s) on the circuit fails and an alarm is generated. The system will retry after five minutes.
1CT/RSM ON WSHP!	1 water circuit per RSM on the WSHP. If the RSM was incorrectly configured to control 2 Condenser Outputs, this alarm will appear.



7.4.1.1. Alarm History Screens

The ALARM HISTORY screen displays past alarms, if any, and how long ago the last of each type occurred. From the ALARM HISTORY screen, press <ENTER> to scroll through the history screens.

The first line is the ALARM NAME.

The second line shows how long ago each alarm last occurred. The screen displays:

- minutes for the first 60 minutes of alarm occurrence
- hours for the next 72 hours of alarm occurrence
- days for the next 30 days of alarm occurrence

Alarms clear after 30 days.

NOTE: Alarm history is not stored in memory. So, if power is lost, the alarms will clear.

The ALARM HISTORY screens follow the same sequence as the ALARMS screens but are abbreviated differently to allow space to show the time since the last occurrence.

Table 49: Alarm History

Alarm History	
Alarm	Alarm History
NO ALARMS	NO ALARM HISTORY
EBUS SLV TIMEOUT	COMM T/O
NO SUCT DETECTED	SP SENSE
NO HEAD DETECTED	HP SENSE
HIGH HP DETECTED	HIGH HP
LOW SP FAILURE	LOW SP
LOW SP DETECTED	NO ALARM HISTORY RECORDED
COMP A1 FAULT	COMP 1 FL
COMP B1 FAULT	COMP 1 FL
COMP A2 FAULT	COMP 2 FL
COMP B2 FAULT	COMP 2 FL
HIGH DIS LINETEMP	HI DILT 1
NO WATER FLOW	NOH ₂ O TMP
LOW H ₂ O TEMP	LOH ₂ O TMP
EMERGENCY SHUTDOWN	NO ALARM HISTORY RECORDED
ENVELOPE FAULT	NO ALARM HISTORY RECORDED

7.5. Protected Screens

7.5.1. Protected Screens Map

Refer to the following map when navigating through the LCD Protected Screens. From the RM454-D Screen, press <ENTER> twice to get to the Software Screen. Then hold the <UP> button for five seconds. To scroll through the rest of the screens, press the <MENU> button. The PROTECT SCREENS map is the following:



Figure 10: Protected Screens Map

7.6. Diagnostic Screens

7.6.1. Diagnostic Screens Map

Refer to the following map when navigating through the Diagnostic Screens. From the DIAGNSTC Screen, press <ENTER> to scroll through the screens.

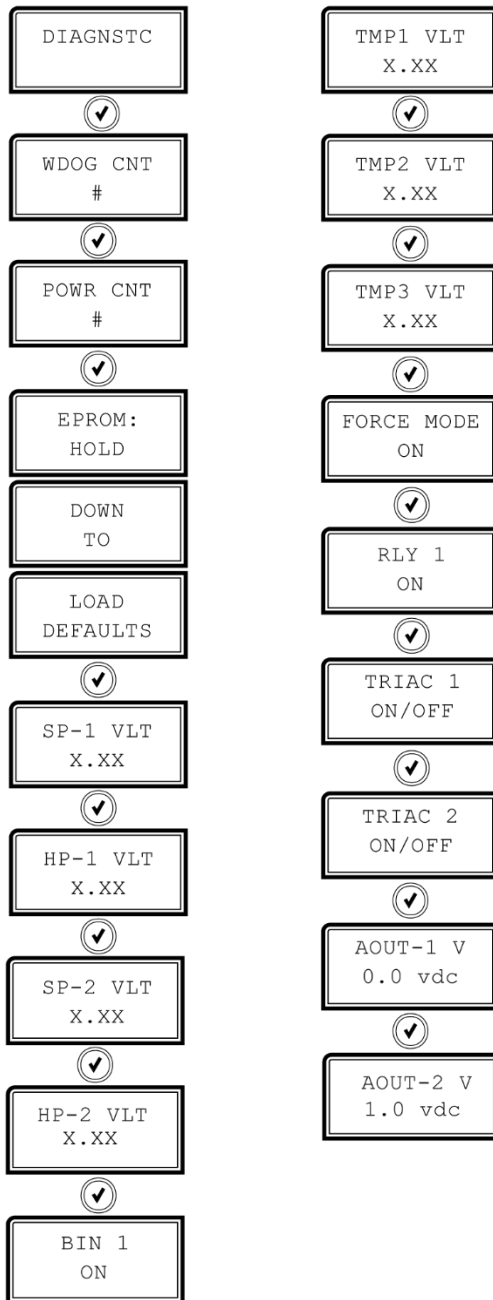

Figure 11: Diagnostic Screens Map

7.6.2. Diagnostic Screens

Refer to Table 50 below when navigating through the Diagnostic Screens. From the DIAGNSTC Screen, press <ENTER> to scroll through the screens.

Table 50: Diagnostic Screens

Diagnostic Screens	
Screen Text	Descriptions
DIAGNSTC	Diagnostic screens
WDOG CNT	Watchdog Timer. Displays the number of times the board has been reset due to watchdog timer overview.
POWR CNT	Power Loss Count. Displays the number of times the board has been reset due to power loss.
SP-1 VLT	Suction Pressure Transducer 1 Voltage. Displays the current voltage of the Suction Pressure Transducer 1.
HP-1 VLT	Head Pressure Transducer 1 Voltage. Displays the current voltage of the Head Pressure Transducer 1.
SP-2 VLT	Suction Pressure Transducer 2 Voltage. Displays the current voltage of the Suction Pressure Transducer 2.
HP-2 VLT	Head Pressure Transducer 2 Voltage. Displays the current voltage of the Head Pressure Transducer 2.
BIN 1	Binary Inputs #1 - #4. Displays the current status of each Binary Input.
TMP1 VLT	Coil Temperature Sensor 1 Voltage. Displays the current voltage of Coil Temperature Sensor 1.
TMP2 VLT	Coil Temperature Sensor 2 Voltage. Displays the current voltage of Coil Temperature Sensor 2.
TMP3 VLT	Coil Temperature Sensor 3 Voltage. Displays the current voltage of Coil Temperature Sensor 3.
FORCE MODE	Force Mode. Displays the current status of Force Mode. Values are ON/OFF.
RLY 1	If Force Mode is on, the following screens will appear. Relays 1 - 5 Force Mode. Press the <UP> or <DOWN> buttons to select ON or OFF for each relay.
TRIAC 1	TRIAC 1. Displays the current status of Digital Compressor 1. Values are ON/OFF.
TRIAC 2	TRIAC 2. Displays the current status of Digital Compressor 2. Values are ON/OFF.
AOUT-1 V	Condenser Signal 1 Force. 0.0 to 10.0 = Active Force Mode. Press the <UP> or <DOWN> buttons to increase and decrease the value.
AOUT-2 V	Condenser Signal 2 Force. 0.0 to 10.0 = Active Force Mode. Press the <UP> or <DOWN> buttons to increase and decrease the value.

7.7. Address Screen



CURRENT BOARD ADDRESS

Configure the address according to which refrigerant circuit this module represents:

1=A, 2=B, 3=C, or 4=D

The number in parentheses is the E-BUS address.

- Module 1's address is 152
- Module 2's address is 153
- Module 3's address is 154
- Module 4's address is 155

8. TROUBLESHOOTING

8.1. LED Diagnostics

8.1.1. Using LEDs to Verify Operation

The RM454-D is equipped with LEDs that can be used to verify operation and perform troubleshooting. There are LEDs for communication, operation modes, and diagnostic codes. See Figure 12 for the LED locations. The LEDs associated with these inputs and outputs show what is active without using a voltmeter. The LEDs and their uses are as follows:

8.1.1.1. Diagnostic LEDs

STATUS

If the software is running, this LED blinks at a rate of one blink per second.

ALARM (above LCD display)

This red LED lights up and stays lit when there is an alarm present. The type of alarm displays on the LCD display.

COMM

Every time the module receives a valid E-BUS request from the VCCX-454 Controller, this LED blinks on and then off, signifying that it received a valid request and responded.

POWER

This LED lights up to indicate that 24 VAC power has been applied to the controller.

8.1.1.2. Binary Input LEDs

BIN1

This green LED lights up when the Compressor Status 1 contact is closed.

BIN2

This green LED lights up when the Compressor Status 2 switch is closed.

BIN3

This green LED lights up when the Outside Coil Temperature switch or proof of water flow switch is closed.

BIN4

This green LED lights up when the Emergency Shutdown switch is closed.

8.1.1.3. Relay LEDs

R1, R2, R3, R4, R5

These green LEDs light up when the relays are enabled and stay lit as long as they are active. R4 is not used.

8.1.1.4. Digital or 2-Step Compressor LEDs

COMP1

This green LED lights up when Digital Compressor 1 is unloading, or 2-Step Compressor 1 is fully loaded.

COMP2

This green LED lights up when Digital Compressor 2 is unloading, or 2-Step Compressor 2 is fully loaded.

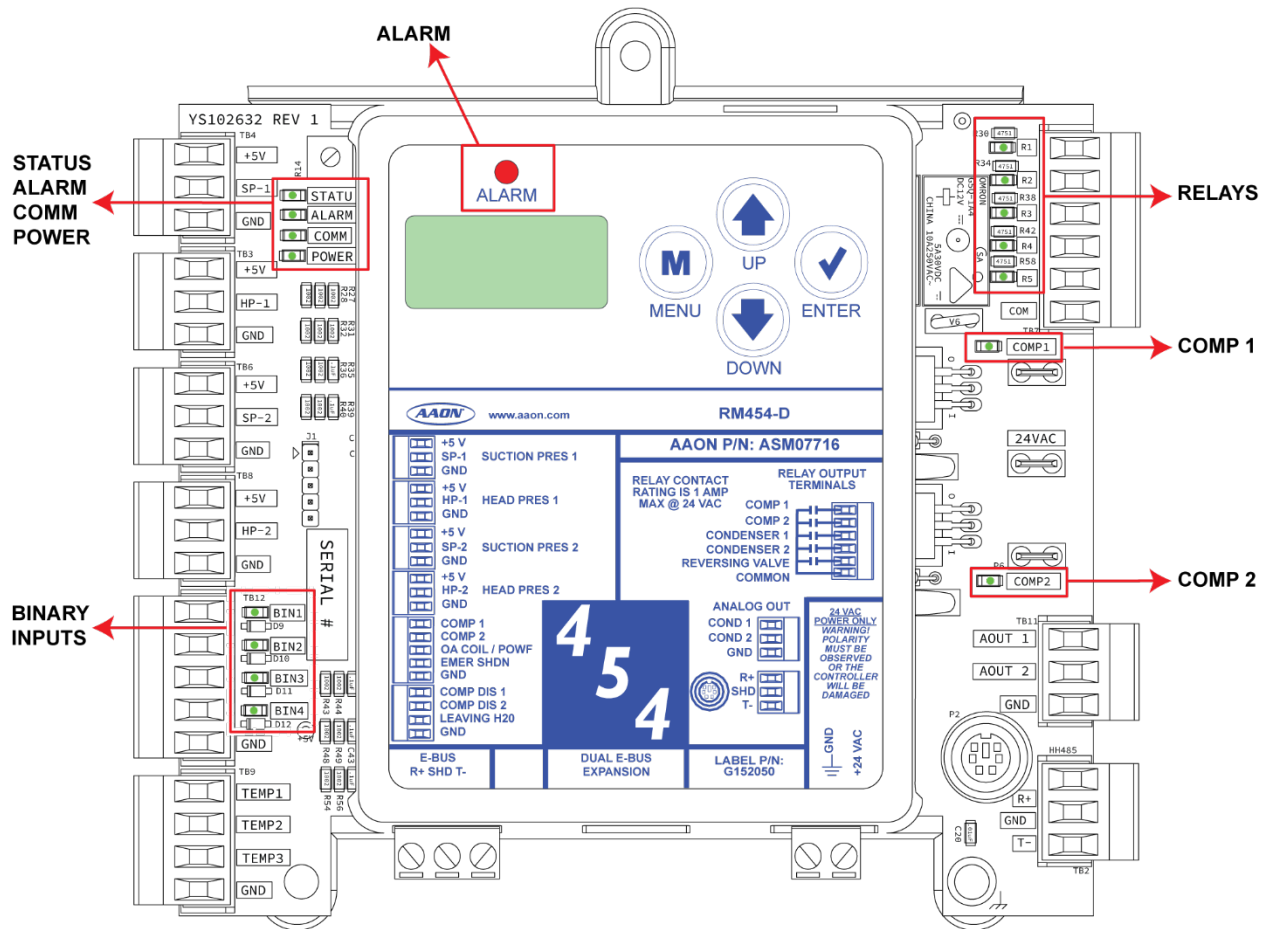

Figure 12: RM454-D LED Locations

8.2. Suction Pressure Transducer Testing

8.2.1. Suction Pressure Transducer Testing for R454 Refrigerant

The Evaporator Coil Temperature is calculated by converting the Suction Pressure to Temperature. The Suction Pressure is obtained by using the Suction Pressure Transducer, which is connected to the suction line of the compressor.

Use the voltage column to check the Suction Pressure Transducer while connected to the RM454-D Module(s). The VCCX-454 and the RM454-D Module(s) must be powered for this text. Read the voltage with a meter set on DC volts. Place the positive leads from the meter on the SP1/SP2 terminal located on the RM454-D Module(s) terminal block. Place the negative lead from the meter on the ground (GND) terminal located adjacent to the SP1/SP2 terminal on the RM454-D Module(s) terminal block. Use a refrigerant gauge set and or an accurate electronic thermometer to measure the temperature or suction line pressure near where the Suction Pressure Transducer is connected to the suction line.

Measure the voltage at the SP1/SP2 and GND terminals and compare it to Table 51, this page. The chart is based on exactly 5.00 volts being supplied to the transducer. If the supply voltage is less than or greater than 5.00, the signal voltage will be slightly more or less than the chart. If the signal voltage is within ± 0.20 volts, the Suction Pressure Transducer is functioning within normal parameters. If not, contact AAON Technical Support for further troubleshooting.

See Table 51 on the right. The table shows a temperature range from 20°F to 80°F. For troubleshooting purposes, the DC voltage readings are also listed with their corresponding temperatures and pressures.

Table 51: Coil Pressure/Voltage/Temp for Suction Pressure Transducers - R454 Refrigerant

Suction Pressure Transducer Coil Pressure Temperature and Voltage Chart For R454 Refrigerant			
Temperature (°F)	Temperature (°C)	Pressure (psi)	Signal DC Volts
25.88	-3.4	80.94	1.8
29.42	-1.4	87.16	1.9
32.81	0.5	93.39	2.0
36.05	2.6	99.62	2.1
39.16	4.0	105.84	2.2
42.15	5.6	112.07	2.3
45.02	7.2	118.29	2.4
47.79	8.8	124.52	2.5
50.47	10.3	130.75	2.6
53.06	11.7	136.97	2.7
55.57	13.1	143.20	2.8
57.99	14.4	149.42	2.9
60.36	15.8	155.65	3.0
62.65	17.0	161.88	3.1
64.88	18.3	168.10	3.2
67.05	19.5	174.32	3.3
69.16	20.6	180.55	3.4
71.23	21.8	186.78	3.5
73.24	22.9	193.00	3.6
75.20	24.0	199.23	3.7
77.12	25.1	205.46	3.8
79.00	26.1	211.68	3.9
80.83	27.1	217.91	4.0
82.63	28.1	224.14	4.1
84.39	29.1	230.36	4.2
86.11	30.1	236.59	4.3

8.3. Temperature Sensor Testing

8.3.1. Copeland Discharge Thermistor Temperature Sensor Testing

Table 52 below is provided to aid in checking sensors that appear to be operating incorrectly. Many system operating problems can be traced to incorrect sensor wiring. Be sure all sensors are wired per the wiring diagrams in this manual.

If the sensors still do not appear to be operating or reading correctly, check the voltage and/or resistance to confirm that the sensor is operating correctly per the table below. Please follow instructions when checking the sensors.

8.3.1.1. Thermistor Sensor Testing Instructions

Use the resistance column to check the thermistor sensor while disconnected from the controllers (not powered).

Use the voltage column to check the sensors while connected to powered controllers. Read the voltage with the meter set on DC volts. Place the “-” (minus) lead on the GND terminal and the “+” (plus) lead on the sensor input terminal being investigated.

NOTE: If the voltage is above 4.98 VDC, then the sensor or wiring is “open.” If the voltage is less than 0.38 VDC, then the sensor or wiring is shorted.

Table 52: Discharge Thermistor Temperature/Resistance

Discharge Thermistor Temperature/Resistance							
Temp (°F)	Temp (°C)	Resistance (K Ohms)	Voltage @ Input (VDC)	Temp (°F)	Temp (°C)	Resistance (K Ohms)	Voltage @ Input (VDC)
-40	-40	2889.60	4.98	167	75	12.73	2.80
-31	-35	2087.22	4.97	176	80	10.79	2.59
-22	-30	1522.20	4.96	185	85	9.20	2.39
-13	-25	1121.44	4.95	194	90	7.87	2.19
-4	-20	834.72	4.94	203	95	6.77	2.01
5	-15	627.28	4.92	212	100	5.85	1.84
14	-10	475.74	4.89	221	105	5.09	1.68
23	-5	363.99	4.86	230	110	4.45	1.53
32	0	280.82	4.82	239	115	3.87	1.39
41	5	218.41	4.77	248	120	3.35	1.25
50	10	171.17	4.72	257	125	2.92	1.12
59	15	135.14	4.65	266	130	2.58	1.02
68	20	107.44	4.57	275	135	2.28	0.92
77	25	86.00	4.47	284	140	2.02	0.83
86	30	69.28	4.36	293	145	1.80	0.76
95	35	56.16	4.24	302	150	1.59	0.68
104	40	45.81	4.10	311	155	1.39	0.61
113	45	37.58	3.94	320	160	1.25	0.55
122	50	30.99	3.77	329	165	1.12	0.50
131	55	25.68	3.59	338	170	1.01	0.45
140	60	21.40	3.40	347	175	0.92	0.42
149	65	17.91	3.20	356	180	0.83	0.38
158	70	15.07	3.00				

8.3.2. Sensor Voltage and Resistance

The following sensor voltage and resistance table is provided to aid in checking sensors that appear to be operating incorrectly. See Table 53 below. Many system operating problems can be traced to incorrect sensor wiring. Be sure all sensors are wired per the wiring diagrams in this manual.

If the sensors still do not appear to be operating or reading correctly, check the voltage and/or resistance to confirm that the sensor is operating correctly per the tables. Please follow instructions when checking sensors.

8.3.2.1. Thermistor Sensor Testing Instructions

Use the resistance column to check the thermistor sensor while disconnected from the controllers (not powered).

Use the voltage column to check sensors while connected to powered controllers. Read the voltage with the meter set on DC volts. Place the "-" (minus) lead on the GND terminal and the "+" (plus) lead on the sensor input terminal being investigated.

NOTE: If the voltage is above 4.88 VDC, then the sensor or wiring is "open." If the voltage is less than 0.05 VDC, then the sensor or wiring is shorted.

Table 53: 0-5V Temperature Sensor - Voltage & Resistance for Type III Sensors

Temperature - Resistance - Voltage for Type III 10 K Ohm Thermistor Sensors							
Temp (°F)	Temp (°C)	Resistance (Ohms)	Voltage @ Input (VDC)	Temp (°F)	Temp (°C)	Resistance (Ohms)	Voltage @ Input (VDC)
-10	-23.3	93333	4.51	72	22.2	11136	2.635
-5	-20.6	80531	4.45	73	22.8	10878	2.605
0	-17.8	69822	4.37	74	23.3	10625	2.576
5	-15	60552	4.29	75	23.9	10398	2.549
10	-12.2	52500	4.2	76	24.4	10158	2.52
15	-9.4	45902	4.1	77	25	10000	2.5
20	-6.6	40147	4.002	78	25.6	9711	2.464
25	-3.9	35165	3.891	80	26.7	9302	2.41
30	-1.1	30805	3.773	82	27.8	8893	2.354
35	1.7	27140	3.651	84	28.9	8514	2.3
40	4.4	23874	3.522	86	30	8153	2.246
45	7.2	21094	3.39	88	31.1	7805	2.192
50	10	18655	3.252	90	32.2	7472	2.139
52	11.1	17799	3.199	95	35	6716	2.009
54	12.2	16956	3.143	100	37.8	6047	1.884
56	13.3	16164	3.087	105	40.6	5453	1.765
58	14.4	15385	3.029	110	43.3	4923	1.65
60	15.6	14681	2.972	115	46.1	4449	1.54
62	16.7	14014	2.916	120	48.9	4030	1.436
64	17.8	13382	2.861	125	51.7	3656	1.339
66	18.9	12758	2.802	130	54.4	3317	1.246
68	20	12191	2.746	135	57.2	3015	1.159
69	20.6	11906	2.717	140	60	2743	1.077
70	21.1	11652	2.691	145	62.7	2502	1.001
71	21.7	11379	2.661	150	65.6	2288	0.931

8.4. Head Pressure Transducer

If there is a suspected problem related to the Head Pressure Transducer, voltage and pressure readings can be taken at the head pressure terminal. See Table 54 below.

Table 54: Head Pressure Transducer Chart

Head Pressure Transducer Chart			
Voltage	Pressure	Voltage	Pressure
0.5	0	2.6	350
0.6	17	2.7	367
0.7	33	2.8	384
0.8	50	2.9	400
0.9	67	3.0	417
1.0	83	3.1	434
1.1	100	3.2	450
1.2	117	3.3	467
1.3	133	3.4	484
1.4	150	3.5	500
1.5	167	3.6	517
1.6	183	3.7	534
1.7	200	3.8	550
1.8	217	3.9	567
1.9	233	4.0	584
2.0	250	4.1	600
2.1	267	4.2	617
2.2	283	4.3	634
2.3	300	4.4	650
2.4	317	4.5	667
2.5	334		



9. REVISION HISTORY

RM454-D Controller Technical Guide Change Log	
Revision and Date	Change
Rev. A, January, 2025	Initial release.
Rev. B, February, 2026	Updated document formatting. Updated Alarms Screens Table.
Rev. C, April 27, 2026	Updated the titles for Tables: 10, 11, 22, and 23.



AAON Controls Support:

Support.Controls@aaon.com

Controls Support Website:

www.aaon.com/aaon-controls-technical-support

AAON Factory Technical Support:

Technical.Support@aaon.com

Phone:

866-918-1100

Monday through Friday, 7:00 AM to 5:00 PM Central Time

Before calling Technical Support, have the model and serial number of the unit available.

For replacement parts, contact your local AAON Representative.

Are you an AAON Rep? Visit My AAON to open new support tickets, communicate directly with our support teams, and track your support progress in one place.

It is the intent of AAON to provide accurate and current product information. However, in the interest of product improvement, AAON reserves the right to change pricing, specifications, and/or design of its product without notice, obligation, or liability.

AAON® is a registered trademark of AAON, Inc., Tulsa, OK. BACnet® is a registered trademark of ASHRAE Inc., Atlanta, GA. BITZER is a registered trademark of BITZER® Kühlmaschinenbau GmbH. Copeland Scroll™ is a registered trademark of Emerson Electric Co., Saint Louis, MO.

Copyright © AAON, all rights reserved throughout the world.

AAON® is a registered trademark of AAON, Inc., Tulsa, OK. AAON® assumes no responsibility for errors or omissions in this document.

This document is subject to change without notice.