



# SA Series



## VERTICAL SELF CONTAINED UNITS & INDOOR AIR HANDLERS



### Features:

- Water-cooled or air-cooled condenser vertical self contained units with capacities from 23-70 tons
- Air-source, water-source, and geothermal heat pump options
- Variable capacity (10-100%) R-410A scroll compressors for load matching cooling and heat pump heating with improved part load efficiency
- Modular design with compact footprint ideal for retrofit applications
- Single or double sided air intake
- Double wall rigid polyurethane foam panel construction reduces air leakage and dampens resonated sound
- Spring isolated direct drive backward curved plenum supply fans
- Optional modulating humidity control
- Shell and tube or brazed plate water-cooled condensers
- Available with a waterside economizer coil for energy savings
- Service access doors
- Double sloped stainless steel drain pans are standard
- Optional hot water or steam preheating
- Available as an indoor DX or chilled water coil air handling unit from 5,300-27,000 cfm

Application Flexibility  
Minimizes Installation Time and Reduces Cost

○ *Makeup Air Applications  
Up to 100% Outside Air*

○ *Dehumidification and  
Filtration Capabilities*

○ *Variable Capacity  
Scroll Compressors*

○ *Factory Installed or Customer  
Specific Controls Options*

# SA Series

## Self Contained Units

*The SA Series leads the industry in self contained unit technology and performance. Variable capacity scroll compressors, direct drive backward curved plenum supply fans, double wall rigid polyurethane foam insulated cabinet construction and optional heat pump configuration provide the SA Series with unmatched performance.*

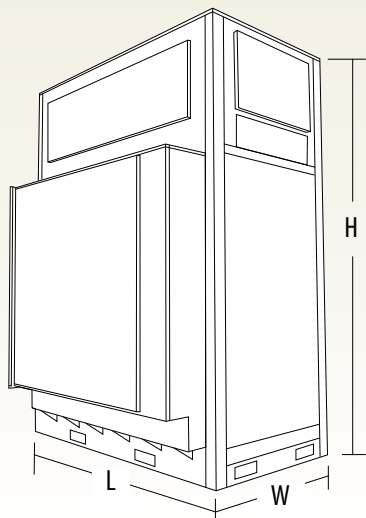

### Superior Features

- Two-inch double wall rigid polyurethane foam panel cabinet construction has a thermal resistance of R-13 or greater, which exceeds the R-value of a cabinet with four-inch thick fiberglass construction. Panels include a thermal break, with no metal contact from inside to outside, to prevent heat transfer through the panel and prevent condensation on the outside of the cabinet. The inner wall protects the insulation from moisture damage, prevents microbial growth, and is easy to clean. This type of construction also makes the cabinet more rigid and resistant to damage, provides increased sound dampening, and reduces air leakage and infiltration.
- Service access doors are double wall, include handles and have full length stainless steel piano hinges which make the unit easily serviceable. Compressor and control service access doors feature zinc cast lockable handles.
- Compressors and controls are contained within a compartment isolated for the air stream for ease of service and increased sound dampening.
- 10-100% variable capacity R-410A scroll compressors allow for load matching cooling and heat pump heating.
- Direct drive backward curved plenum supply fans provide improved energy efficiency and reduced maintenance versus belt driven fans.
- Multiple, spring isolated, fan configurations give the unit redundancy, lower sound and vibration levels and the flexibility to meet job requirements.
- Single or multiple supply air connections can be factory provided from the right, left, back, or top sides of the supply fan plenum.
- Shell and tube or brazed plate water-cooled condensers provide improved unit efficiency and design flexibility.
- Double sloped stainless steel drain pans eliminate standing water that can support microbial growth and stainless steel construction prevents corrosion that could lead to water leaks and contaminants in the air stream.
- Run test report, wiring diagram and Installation, Operation and Maintenance manual with startup form are provided in controls access compartment.
- Compressors include 5 year non-prorated warranty.

### Premier Options

- Heat pump configuration allows for energy efficient heating and cooling.
- Waterside economizer for free cooling during low ambient conditions.
- VFD controlled supply fans for precise airflow control and reduced power consumption.
- Plenum height options in increments of 4 inches allow the unit to meet the space requirements.
- Modulating humidity control provides energy efficient dehumidification, even at low sensible heat loads, without the temperature swings common with on/off reheat systems.
- Available as a DX air handler to match with an air-cooled condenser for application flexibility.
- Chilled water cooling coils allow unit to tie into existing chilled water system.
- Hot water or steam preheating coils allow unit to tie into existing boiler system.
- Polymer e-coated coils are available to extend the life of the coils and protect them in corrosive environments.
- Multiple filtration options.

SA Model	Intake	Nominal cfm	Height*	Length	Width*
23	Single	6,900	111-135 (in 4 inch increments)	79	55
28		8,400			
30		9,000			
35		10,500			
45	Double	13,500			110 <sup>†</sup>
50		15,000			
55		16,500			
58		17,400			
60		18,000			
65		19,500			
70		21,000			

\*Dimensions may vary depending on options selected. All dimensions are in inches.

<sup>†</sup> Double intake units can be split in half for ease of installation.

Maximum cfm may be 30-50% greater than nominal cfm.

# Compact Modular Construction

## Single Sided Intake

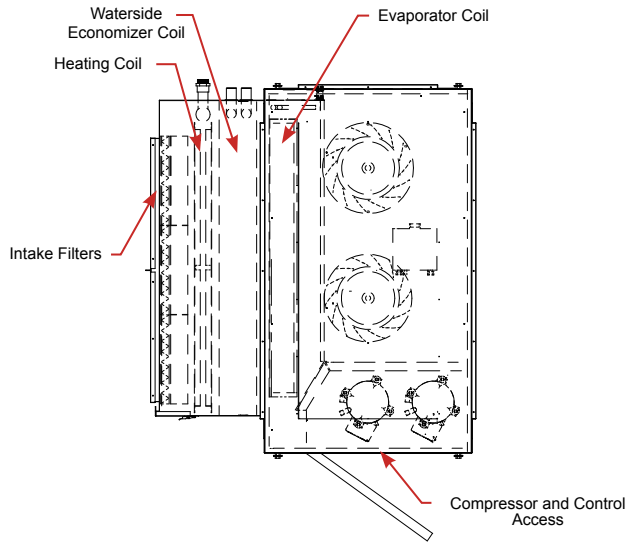

## Double Sided Intake

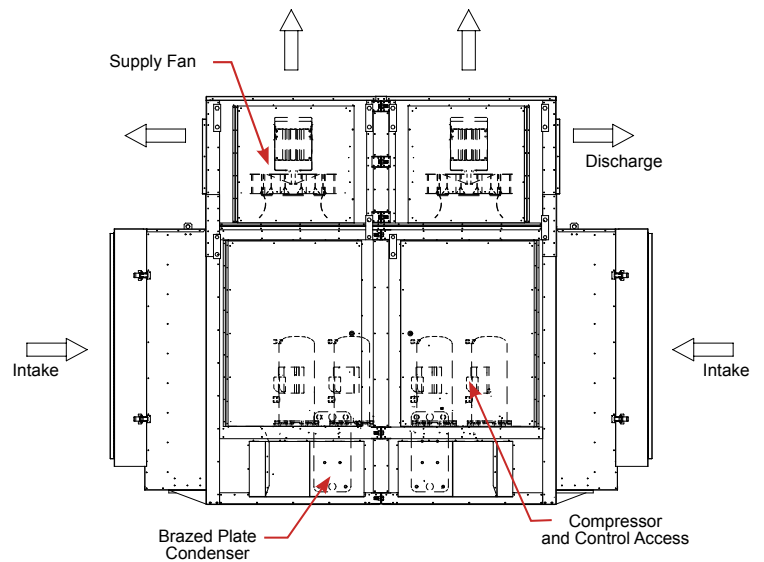
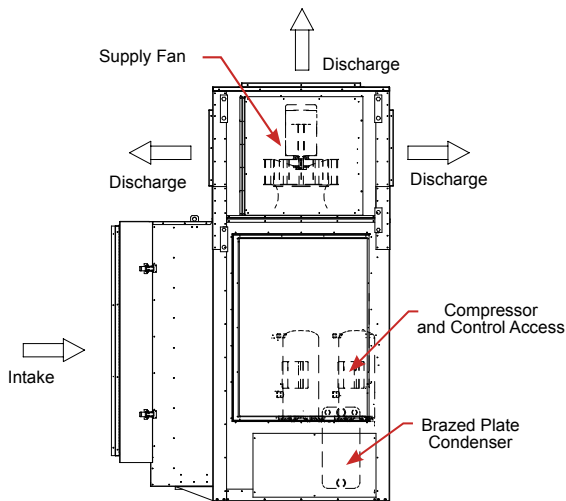
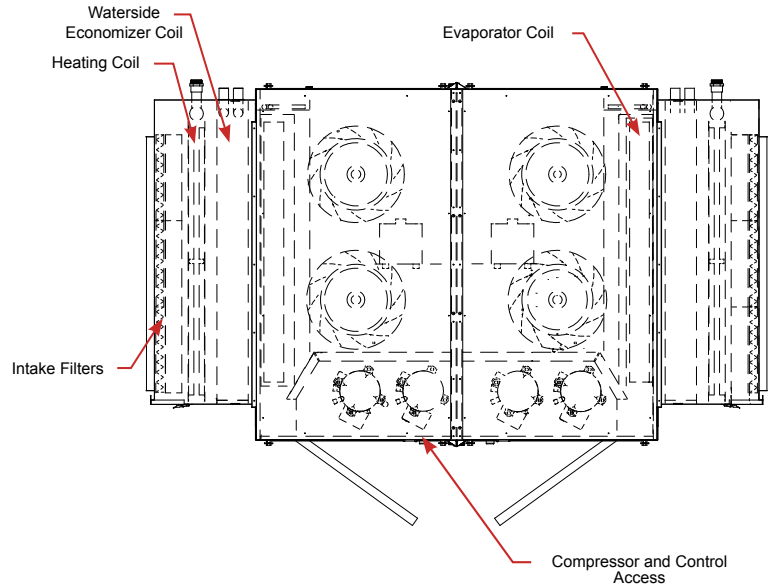

SA Series with Waterside Economizer

## Variable Capacity Scroll Compressors

With 10-100% capacity control these scroll compressors can match the load needed by the unit. The compressors vary the volume of refrigerant that flows through the cooling system allowing the unit to tightly control the air temperature and save energy.

## Heat Pump Configuration

With the heat pump option an SA Series unit can heat the air as energy efficiently as it cools it. By transferring heat from water or air to the building, the SA Series heat pump requires no fossil fuels.

## Modular Design

The SA Series features four capacity sizes with a single air intake (SA-023 to SA-035). The single air intake units can be matched together to provide seven additional sizes (SA-45 to SA-70) with two air intakes.

SA Series

# AAON Environmentally Friendly HVAC Product Family

**Custom & Cataloged  
Air Handling Units** ■ .....  
(800-200,000+ cfm)

**Condensers & Condensing Units** ■ .....  
(2-230 tons)

**Chillers (Air-Cooled, Evaporative-  
Cooled, Heat Pumps)** ■ .....  
(5-540 tons)

**Rooftop Units** ■ .....  
(2-240 tons)

**Outdoor Equipment Rooms** ■ .....  
(Chillers, Boilers & Pumps)

**Self Contained Units** ■ .....  
(3-70 tons)

**Residential Systems** ■ .....  
(2-5 tons)

**Geothermal & WSHP Units** ■ .....  
(2-230 tons)

**Air-Source Heat Pumps** ■ .....  
(2-230 tons)

## Heating and Cooling *for...*

**Auditoriums**  
**Convenience Stores**  
**Health Clubs**  
**Healthcare Facilities**  
**Homes**  
**Lodgings**  
**Manufacturing**  
**Museums & Libraries**  
**Natatoriums**  
**Office Buildings**  
**Restaurants**  
**Retail Stores**  
**Schools**  
**Supermarkets**



Defining Quality. Building Comfort.

2425 S. Yukon Ave.  
Tulsa, OK 74107-2728  
[www.AAON.com](http://www.AAON.com)

It is the intent of AAON to provide accurate and current product information. However, in the interest of product improvement, AAON reserves the right to change pricing, specifications, and/or design of its product without notice, obligation, or liability. Copyright © AAON, all rights reserved throughout the world. AAON® and AAONAIRE® are registered trademarks of AAON, Inc., Tulsa, OK.